

# Flint Knapping:

Articles, Tips, and Tutorials from the  
Internet



*Photo from Flintknapping, Art of the Ancients, 2009 Calender, used with permission*

***3<sup>rd</sup> Edition***

***Compiled/Edited by Michael Lynn***



*Photo of Tim Dillard teaching me at the  
Center for American Archaeology in Kampsville, IL*

**Dedicated to all those who have taught someone else about the art of flint knapping, especially to my primary teachers – Bruce Boda, Tim Dillard, Mike McGrath and Steve Nissly. This is my attempt to pay forward.**

© Michael Lynn, 2010

Although the copyrights to the individual articles and tutorials in this e-book belong to the authors, I have copyrighted this collection. It may be freely printed, copied, posted on the internet and otherwise distributed as long as said distribution is free and appropriate credit is given to me and the authors. This e-book may not be sold for profit.

# TABLE OF CONTENTS

## Section 1: Basic Concepts

Flintknapping Terminology by Mark Bracken at <a href="http://www.flintknappingtools.com">www.flintknappingtools.com</a>	8
Reduction Sequence by Dan Long at <a href="http://knapper_dan.tripod.com">http://knapper_dan.tripod.com</a>	12
The Anatomy of a Platform by Mark Bracken at <a href="http://www.flintknappingtools.com">www.flintknappingtools.com</a>	18
The Below the Centerline Concept by Wyatt R. Knapp at <a href="http://www.onagocag.com">www.onagocag.com</a>	21
Flakes from Flat Surfaces by Jim Winn (aka Paleoknapperjim) at <a href="http://www.flintknappers.com">www.flintknappers.com</a>	23
A Theory for Flake Creation by Tony Baker at <a href="http://www.ele.net/algorithm/flake_creation/SD_text.htm">www.ele.net/algorithm/flake_creation/SD_text.htm</a>	27
The Ethical Responsibilities of Modern Knappers by James Fisher at <a href="http://www.creeksideartifacts.com">www.creeksideartifacts.com</a>	46
Flintknapping and Silicosis by J. Kalin at <a href="http://pugetsoundknappers.com">pugetsoundknappers.com</a>	48

## Section 2: Tools

What Do You Really Need to Start Flintknapping? by Wyatt R. Knapp at <a href="http://www.onagocag.com">www.onagocag.com</a>	59
Pictures of Modern Tools from Primitive Materials by Charlie (aka Stonefacescar) at <a href="http://www.paleoplanet.net">www.paleoplanet.net</a>	61
Making a Horseshoe Nail Notcher by Mark Dellinges at <a href="http://www.paleoplanet.net">www.paleoplanet.net</a>	68
Making Boopers by Jim Keffer (aka reefera4m) at <a href="http://www.paleoplanet.net">www.paleoplanet.net</a>	71

Something New to me – Notching Jig by Richard Myers (aka Twobears) at <a href="http://www.paleoplanet.net">www.paleoplanet.net</a>	80
Simple Fluting Jig Pictures by Ken Wallace (aka Paleoman52) at <a href="http://www.paleoplanet.net">www.paleoplanet.net</a>	82
Tony Sear’s Fluting Jig by Richard Meyers (aka Twobear) at <a href="http://www.paleoplanet.net">www.paleoplanet.net</a>	85
Rocker Punch Board by Gary Abbatte (aka rhyeswithwhat) at <a href="http://www.paleoplanet.net">www.paleoplanet.net</a>	86
Knapping Aids for the Strength or Dexterity Challenged by James Keffer (aka reefera4m) at <a href="http://www.pugetsoundknappers.com">www.pugetsoundknappers.com</a>	89
Converting a Pottery Kiln to Heat Treat Flint by Mark Bracken at <a href="http://www.flintknappingtools.com">www.flintknappingtools.com</a>	96
Dan’s Cave by Dan Long at <a href="http://knapper_dan.tripod.com">http://knapper_dan.tripod.com</a>	100
Paleoman52’s Cave Pictures by Ken Wallace (aka Paleoman52) at <a href="http://www.paleoplanet.net">www.paleoplanet.net</a>	104
Exhaust Fan Setup by Mark Green (aka Clamdigger) at <a href="http://www.paleoplanet.net">www.paleoplanet.net</a>	106
 <b>Section 3: Percussion</b>	
Platform Preparation Variables in Bifacial Reduction ... by Errett Callahan at <a href="http://www.errettcallahan.com/piltdown.htm">www.errettcallahan.com/piltdown.htm</a>	109
Percussion Flint Knapping Tutorial by Tom Sterling at <a href="http://www.sterlingsculptures.com">www.sterlingsculptures.com</a>	115
Abo Flintknapping Reduction Strategies by Rick Hamilton at <a href="http://www.spiritinthewind.com">www.spiritinthewind.com</a>	121
Using a Rocker Punch by Lucas Nicholson (aka goose) at <a href="http://www.paleoplanet.net">www.paleoplanet.net</a>	129
Punch Work Process Pictures by Marty Ruester (aka Just a Flake) at <a href="http://www.flintknappingtips.com">www.flintknappingtips.com</a>	134

Getting better with Antler Punch by Benjamin Eble at <a href="http://www.paleoplanet.net">www.paleoplanet.net</a>	140
Heavy Hammerstone Spalling – Tripod Setup by Benjamin Eble at <a href="http://www.paleoplanet.net">www.paleoplanet.net</a>	148
Ball Flint Reduction by Gary Merlie at <a href="http://opalvalley.com">http://opalvalley.com</a>	152
Dome and Plane Reduction by Tony Baker at <a href="http://www.ele.net">www.ele.net</a>	
Preventing Broken Points by Wyatt R. Knapp at <a href="http://www.onagocag.com">www.onagocag.com</a>	155
Some Talk about Angles by Wyatt R. Knapp at <a href="http://www.onagocag.com">www.onagocag.com</a>	158
Why You Should Work the Ends and then the Middle! by Wyatt R. Knapp at <a href="http://www.onagocag.com">www.onagocag.com</a>	163
Knapping on the Leg by Wyatt R. Knapp at <a href="http://www.onagocag.com">www.onagocag.com</a>	165
Buffalo Hide as a Leg Pad and Preform Shock Dampening Tool by Wyatt R. Knapp at <a href="http://www.onagocag.com">www.onagocag.com</a>	168
 <b>Section 4: Pressure Flaking</b>	
Small Point Pressure Flaking by F. Scott Crawford at <a href="http://www.arrowhead-makeyourown.com">www.arrowhead-makeyourown.com</a>	173
From Beer Bottle to Arrowhead by Tim Rast at <a href="http://www.cavemanchemistry.com">www.cavemanchemistry.com</a>	174
How to Make Your Own Arrowhead by F. Scott Crawford at <a href="http://www.arrowhead-maker.com">www.arrowhead-maker.com</a>	179
Using Your Legs When Pressure Flaking by F. Scott Crawford at <a href="http://www.arrowhead-makeyourown.com">www.arrowhead-makeyourown.com</a>	186
Why Pressure Flakes Fall Short by Mark Bracken at <a href="http://www.flintknappingtools.com">www.flintknappingtools.com</a>	188
Slab Knapping Tutorial by Mike Tylzynski (aka Idaho Clovisman) at <a href="http://www.paleoplanet.net">www.paleoplanet.net</a>	189

Pressure Flaking a Big Blade from a Slab by Jim Winn (aka Paleoknapperjim) at <a href="http://www.paleoplanet.net">www.paleoplanet.net</a>	203
Flake Over Grind (FOG) 101 by Tom Dodge (aka peblpmp) at <a href="http://www.paleoplanet.net">www.paleoplanet.net</a>	216
Parallel Flaking Techniques by Jim Winn (aka Paleoknapperjim) at <a href="http://www.flintknappers.com">www.flintknappers.com</a>	223
Micro Flint-Knapping by Craig Libuse at <a href="http://www.craftsmanshipmuseum.com">www.craftsmanshipmuseum.com</a>	226
<b>Section 5: Fluting &amp; Notching</b>	
Fluting Instructions by Gary Merlie at <a href="http://www.ssr.si.org">www.ssr.si.org</a>	232
Hand Fluting by Bob Patten (aka Knapperbob) at <a href="http://www.paleoplanet.net">www.paleoplanet.net</a>	235
Folsom Workshop Fluting Experiments by Tony Baker at <a href="http://www.wlw.net">www.wlw.net</a>	241
Making Fluted Points with the Sollberger Jig by Woody Blackwell at <a href="http://www.pugetsoundknappers.com">www.pugetsoundknappers.com</a>	246
Notching Arrowheads by F. Scott Crawford at <a href="http://www.arrowhead-makeyourown.com">www.arrowhead-makeyourown.com</a>	259
The Basics of Punch Notching by Mark Bracken at <a href="http://www.flintknappingtools.com">www.flintknappingtools.com</a>	261
Punch Notching an Andice by Kinley Coyan (aka elremolino) at <a href="http://www.paleoplanet.net">www.paleoplanet.net</a>	263
Expanding Type Notching Tutorial – Crump Lake Point by Jim Winn (aka Paleoknapperjim) at <a href="http://www.paleoplanet.net">www.paleoplanet.net</a>	266

## **Section 6: Finding & Treating Knappable Stone**

Where Can I Find Flint? by Mark Bracken at <a href="http://www.flintknappingtools.com">www.flintknappingtools.com</a>	285
Rockhounding Law by Gregory Tolbert at <a href="http://www.gatorgirlrocks.com">www.gatorgirlrocks.com</a>	286
Flintknapping Buyers Tips by Wilkie Collins at <a href="http://www.nativewayonline.com">www.nativewayonline.com</a>	297
Heat Treatment by Travis Smolinski at <a href="http://www.sparrowcreek.com">www.sparrowcreek.com</a>	300
Heat Treating Tips and Temperatures by Mark Bracken at <a href="http://www.flintknappingtools.com">www.flintknappingtools.com</a>	305
Heat Treating Time/Temperature Table by Richard Urata	308

## **Section 7: Displaying & Making Things with Your Points**

Scanning Your Points by Michael Miller (aka mjflinty) at <a href="http://www.paleoplanet.net">www.paleoplanet.net</a>	314
Photographing Stone Points by Chris Merriam at <a href="http://www.arrowheadsonline.com/pages/photography.htm">www.arrowheadsonline.com/pages/photography.htm</a>	315
Point Displays with Girl Power by Gary Abbatte (aka rhymeswithwhat) at <a href="http://www.paleoplanet.net">www.paleoplanet.net</a>	321
New Look for Display Case by Mutt (aka Mutt.vets) at <a href="http://www.paleoplanet.net">www.paleoplanet.net</a>	324
Cord Wrapping for an Arrowhead Necklace by Kyle (aka Potholes Primitive) at <a href="http://www.paleoplanet.net">www.paleoplanet.net</a>	325
Wire Wrapping for an Arrowhead Necklace by Jim (aka Flyfish) at <a href="http://www.paleoplanet.net">www.paleoplanet.net</a>	326
Hafting Blades into Knives by Travis Smolinski at <a href="http://www.sparrowcreek.com">www.sparrowcreek.com</a>	327



## **Section 1: Basic Concepts**



# Flintknapping Terminology

by Mark Bracken

Here are some helpful descriptive terms commonly used in knapping...

- **Abrading**... The process of polishing the edge of a preform's platform to strengthen it in preparation for flake removal by percussion or pressure flaking.
- **Biface**... A spall or piece of flint that has been flaked on both sides.
- **Bulb**... Often called "The bulb of percussion" it is the area very close to the edge or margin of the biface where the flake originates due to pressure or percussion work. It can sometimes be deep and cause significant concavities along the edge. The bulb should be kept at a minimum. See drawing
- **Center Line**... This term is used to describe the imaginary centerline of a preform as viewed from the blade edge. See drawing

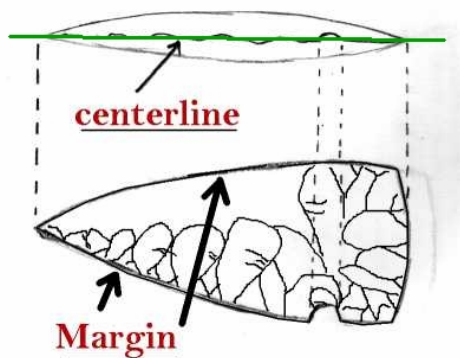

- **Cobble**... Some flints occur in cobble form. These are irregular shaped but smooth, and are formed in various sizes averaging from one to 5 pounds and are generally covered with a cortex.
- **Concave**... A "cupped" area on the face of a preform or nodule. This should be avoided until the material around it has been removed thus raising this "negative" area to match the contour of the rest of the Blade or core.

- **Convex**... The opposite of concaved. It is a rounded raised area. A lens shape is a good example. This is the foundation for good successful flaking!
- **Core**... The "mother stone" or nodule which spalls are removed from. Also a carefully prepared worked piece of flint that Sharp useable blades are removed from.
- **Cortex**... The outer "skin" of a flint nodule or spall. Usually a chalky white or brown material ranging from 1" to 1/4" thick.
- **Flake**... A thin, sometimes broad and sharp piece of stone chipped from a larger biface or preform.
- **Flake Scar**... This is the "scar" left behind where a flake has been removed.
- **Flute Flake**... A special flake removed from the base of a blade or preform that travels up the face towards the tip. The purpose of this flake was to create a concaved channel to aid in the special hafting technique of Paleo era points.
- **Heat Treating**... Flint was often heat treated by North American peoples. Things are no different today! The flint is very slowly heated and cooled to temperatures ranging from 350-700 F, depending on the material quality and type. Not all flints benefit from heat treating. Heat treating gives the flint a glass like attribute making it easier to chip.
- **Hinge Fracture**... This is an undesirable flake that falls short of it's mark by "rolling" out. See image.



- **Isolated Platform**... This is a platform that has been "isolated" from the material around it. This is done by carefully chipping the stone away from either side of it. This leaves the platform sticking out a bit. The energy is transferred much farther "down range" using isolations.

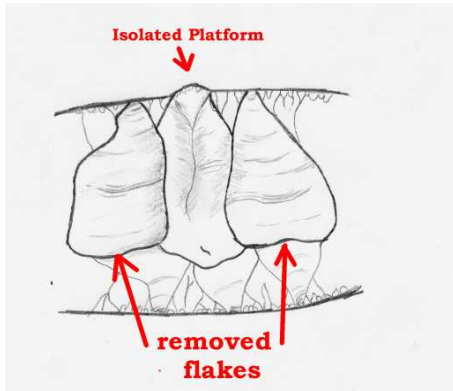

- **Knapping**... The skillful act of chipping flint or making gun flints.
- **Margin**... The edge or circumference of the biface or preform.
- **Nodule**... A large to very large smooth or irregular piece of flint.
- **Overshot Flake**... The affect of a flake that travels from one margin to the other and "clipping" the opposite edge.
- **Platform**... A platform has 3 main components, this is discussed in "platforms". A carefully prepared area on the edge of a preform to be struck to create the desired flake. Or A naturally occurring area on a rough spall or nodule that would produce a desired flake or spall. Platforms are the key to good knapping.
- **Platform Bevel**... This is the part of the platform that is actually struck.
- **Platform Support**... This is the underside of the "bevel". It gives support to the platform at the time of strike.
- **Platform deltas**... These are the results of flake removal. See drawing
- **Preform**... A bifaced blade in various stages of reduction.

- **Pressure Flaking**... The act of removing flakes by pressure using an "Ishi Stick" or flaker.



- **Percussion Flaking**... Removing flakes by directly striking the stone with a **billet**.
- **Raking and Shearing**... Raking is the action of carefully dragging a course abrader or other device to remove "micro" flakes from the edge of a biface or preform to change it's shape or give support to an edge before actual abrading is done prior to percussion or pressure work.
- **Spalling**... The act of breaking up a nodule or cobble into workable and desirable sized pieces.
- **Spalls**... The finished untrimmed large flake removed from a larger "mother" stone.
- **Stack**... Another BAD thing. A series flakes that fall short of a single specific objective. Resulting in multiple failed attempts to remove a specific problem area. Read "**Platforms**" for preventative measures.
- **Step Fracture**... A single flake falling short of it's mark by creating a "step" on the surface of the Blade. The thinner you get the more this demon haunts you.

---

From <http://www.flintknappingtools.com/terms.html> , March 31, 2010, copied with permission

# Reduction Sequence

by Dan Long

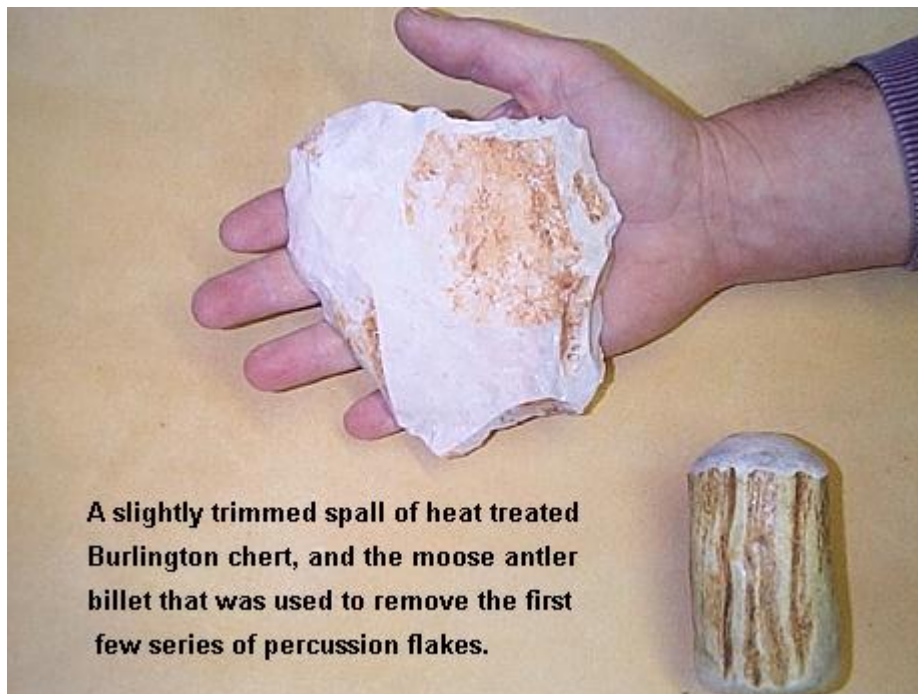

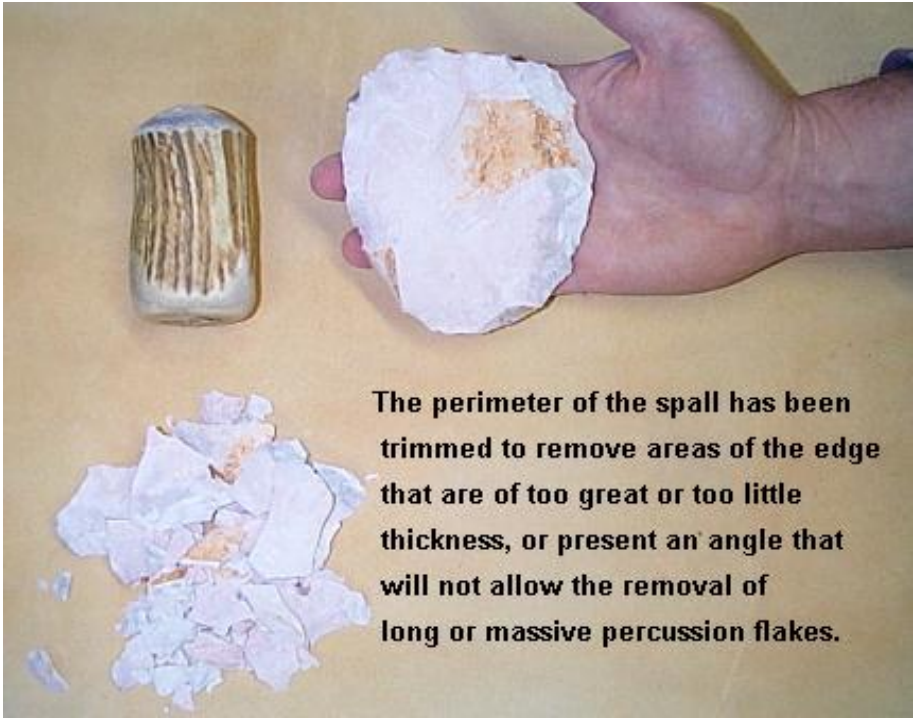

**The perimeter of the spall has been trimmed to remove areas of the edge that are of too great or too little thickness, or present an angle that will not allow the removal of long or massive percussion flakes.**



**Primary Thinning**

**More massive, longer flakes that reach beyond the mid-line of the piece, begin to rapidly thin it as it becomes a biface. (Flaked completely on both faces.)**



**As thinning continues (with a smaller billet), the flakes are less massive but still long, reaching more than halfway across the face.**



**Moving again to a smaller billet as the biface begins to take shape.**

**The mass of the billet should be in proportion with the size of the biface and the desired flakes.**



**The smallest billet used in this reduction for the final percussion flakes.**

**The corners have been removed from the base of the preform in preparation for corner notching.**

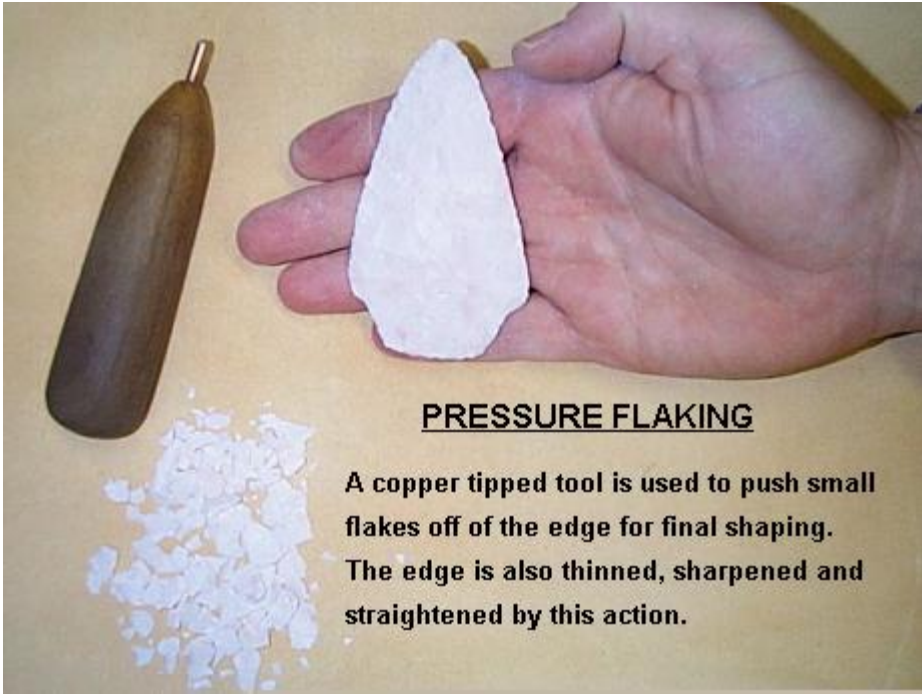

**PRESSURE FLAKING**

**A copper tipped tool is used to push small flakes off of the edge for final shaping. The edge is also thinned, sharpened and straightened by this action.**



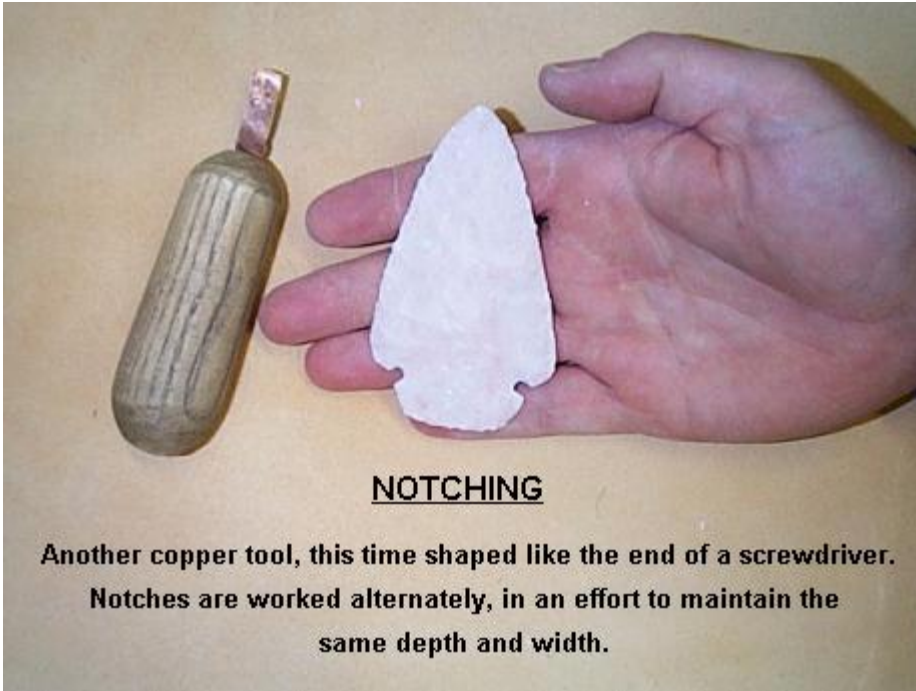

### NOTCHING

**Another copper tool, this time shaped like the end of a screwdriver.  
Notches are worked alternately, in an effort to maintain the  
same depth and width.**



**With notching, final base and edge  
retouch complete, the base and insides  
of the notches are ground smooth in  
preparation for hafting onto a handle  
for use as a knife.**



---

From [http://knapper\\_dan.tripod.com/](http://knapper_dan.tripod.com/), March 31, 2010, copied with permission

# Anatomy of a Platform

by Mark Bracken

Careful and properly built striking platforms are one major key to predictable flake removal. Please note that one must have an understand knapping "terminology" to benefit from this article. Platforms have four basic components. All four components must have the proper characteristics for a flake to be removed predictably, and if it does not, the struck flake (if any) WILL become undesirable. Lets look at the platform's components and why each part is so essential. You must understand that these four components almost always have to be created from scratch. Rarely are they just sitting there waiting for your eager billet! These are also listed in the order they should be made. The descriptions here are intended for bi-facial preform stages but can be applied to spalls. Note that one must be quite proficient with a pressure flaker before you master percussion flaking. This is because great percussion platforms start with good pressure flaking.

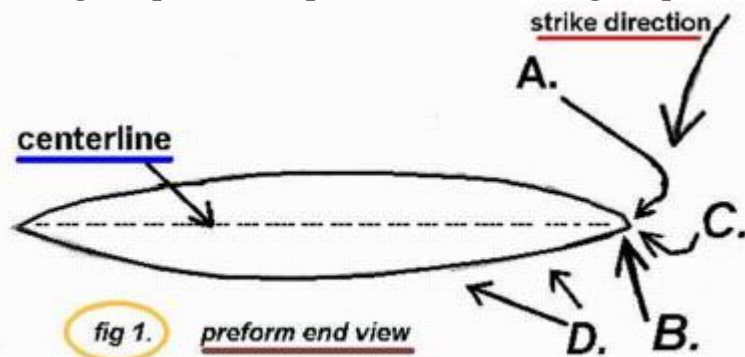

Now that we have divided the platform into four parts, lets give them all a letter code: "A", "B", "C" and "D", as shown in fig. 1. I will discuss the following topics relating to each platform component.

1. It's purpose and/or function
2. "How to make them"
3. The attributes it should have
4. Trouble shooting... cause and effect of poorly made and or Improperly prepared platforms

## **Part A**

The first we will look at is "A". This is the part commonly referred to as the "bevel". The purpose of the "bevel" is that it serves as the surface that is actually struck to produce the flake. How do we go about making the bevel? The most accurate way is to use a SHARP pressure flaker. You can use a billet to produce this on an early stage perform or spall. It is highly recommended that you use a pressure flaker to make this part. What attributes should part "A" have? This part should have a bevel some where near 45 degrees. This angle can be changed by making another "pass" or modifying angle of pressure. The bevel should be smooth. What I mean by this is that it should not contain irregular bumps, humps and micro ridges. It should be just as if you used a router on a piece of wood.

## **Part B**

Part "B" gives support to the strike. It is actually made from part "A". There are many ways to make this. The basic idea is that you're actually removing extremely tiny chips off the bottom or underside of the "bevel". (This is the same side the thinning flake will be removed from.) Remember, your not really abrading the edge so much as shaping it. Here's a couple ways of doing this. The first way is to use a course abrader. Just rake the edge downward gently and repeating this process just long enough to feel less resistance as the abrader is raked downward. You can also rake off these "micro" flakes with the edge of your pressure flaker or use a copper bar to do the same thing. Keep in mind this is a very important step! If you rake it too hard or use or use excessive force it will be too strong and will greatly stress the stone upon striking it. Rake thick performs harder than thin ones. If "B" is not raked enough it will cause the platform to crush or cause a step fracture very close to the edge. Too much and you will break it! So don't over do it.

## **Part C**

Moving onto part "C". This part is also made from "A". It is the polished area that your billet actually strikes. It is better described as polished but commonly referred to as abraded. Polishing sounds so much more precise and civilized. To prepare this part properly one must first have created "A" and "B" flawlessly! You simply grind up and down the platform edge. What I mean by this is your grinding from base to tip. Another description of this is if you're holding the preform flat, the grinding motion is horizontal NOT vertical. A vertical motion will destroy the platform. You want to use course abrasers for preforms thicker than 5 to 1 width to thickness and a medium abrader for thinner bi-faces. Be cautious not to over grind, this will also cause splits or breakage. Keep in mind... the better you make your platforms... the less grinding they will need!

## **Part D**

**Finally part "D". This is what I like to refer to as the "road" the flake will travel down. This must be closely looked at before you decide to remove any material for the purpose of platform construction. If the surface area of part "D" is irregular, then it must be corrected before an attempt at flake removal is made. Simply put, don't waist the time and circumference of your bi-face trying to chip off an area with a stack or concavity. Just work on either side of it. Build platforms to target areas with good convexities. Stay away from concavities. You can modify the surface of your bi-face by pressure flaking if necessary. You must be careful not to cause "micro" steps with your billet or Ishi stick. It will just be more trash for your thinning flake to contend with. Just remember to take your time and analyze. Be safe and have fun!**

---

From <http://www.flintknappingtools.com/platforms.html>, March 31, 2010, copied with permission

# The Below the Center Line Concept

© copyright 1996 by W.R. Knapp

OK...I'll admit it. Just don't snicker and talk about it to anyone, OK? As a beginner, for the longest time, I just couldn't grasp the concept of the center line. Now I don't claim to be a genius, but still... I see myself as fairly quick on the draw. So what was the deal?

First I was confusing my working edge with the center line. Then when I realized that wasn't always so I had trouble visualizing just where it was. But finally I got it! Now it seems so painfully obvious to me I wonder why I had so much trouble with it. I don't feel too bad though, because on Craig Ratzats video "Caught Knapping" he says that this concept is a difficult one for some to grasp.

Mastering the center line concept can help you become a more successful knapper because it helps reduce breakage due to hitting too high into the mass of a preform. Later, as you gain experience, you will learn how to "cheat with the angles" so that you don't have to lose as much size due to taking off part of your edge to get below the centerline.

Well, let's explore the center line concept.

First of all understand that we're talking about the center line of the mass. Let's say you have a piece of stone worked down until it's fairly elliptical. It's a preform now. Hold the preform so that you're looking at it edge on. The drawing in Figure 1 shows this view.



As we look at this piece edge on, we imagine a line extending across the top surface, and also one skimming the bottom. This is depicted in figure one by the two light blue lines. Now all we do is split the distance between those two lines exactly in half and imagine a line that extends through the stone (purple dotted line in Fig.1). This is the center line of that mass.(Seems like it could be called "The Center Plane")

Here's the deal. Until you have lots of experience you must promise this to your flintknapping self. EVERY time that you are about to strike a platform CHECK to be sure that the place where your billet will connect is BELOW THE CENTER LINE. Platforms made and struck below the center line make flakes. When you hit above the center line you fold the piece!



**Fig.2**

Next we can take a look at figure two. It shows a preform with an irregular edge. The center line has been drawn in as a light blue line and, as you can see, sometimes the edge is

above the center line and sometimes it is below it. The two places marked with red X's are safe platforms (striking places). Just for kicks you can imagine the preform in figure two turned upside down. Now where are the safe, below the centerline strikes?

You may wonder why I didn't mark the left side as a safe hit even though there is material below the center line. That's because the angle isn't right on that end for an effective strike. It's leaning the wrong way. Platforms have to be at an angle of less than 90 degrees. You would have to chip or pressure flake at that end until the angle was not only below the center line, but also at an angle less than 90 degrees. But check this out! If you turn the preform upside down you have a platform that fits all the criteria just mentioned. On top of that, if you take a flake off there and then turn the piece back over again, you will not only have thinned one side, but with just a little retouch you will also have prepared a platform for taking a flake off the other side. Nice technique!



**Fig.3**

Finally, lets look at the dilemma presented here by the preform in Figure 3. It's a common scenario, but with experience it's usually pretty obvious. More often you deal with a more subtle version of this example.

We started our light blue center line at end "B" and extended it across the point to end "A". But look what happened to the line when it got to the "A" end. Suddenly it's not in the center of the mass anymore. If we were to strike a platform at this line the piece would very likely fail. The only thing to do is to move the edge down so that our platform would be below the center line of the mass at that end. The real center line of that end is indicated by the purple line. Now we can hit our platform and, providing we're holding the preform at the proper angle, a flake will be removed and things will be very happy.

So next time when you're working on a nice piece and you strike and nothing happens but a sick "clunk" noise...STOP! Where's your platform? Whew! You lucked out--it didn't break. Now move that platform down and try again! Good Luck and Happy Chipping!

---

From <http://www.onagocag.com/center.html>, April 1 2010, Copied with permission

Note: Wyatt R. Knapp is the author of "The New Atlatl and Dart Workbook" to be released Summer 2010.

## Flakes from Flat Surfaces

by Jim Winn (January 27, 2003)

I did some more test flaking on obsidian slabs to observe the shape of the flakes removed. Flakes were removed with pressure using an Ishi stick with a copper tip and another with an antler tip on the 1<sup>st</sup> test. And a 2<sup>nd</sup> test was performed with percussion using both copper and antler. All of the slabs were photographed afterward showing the slabs as well as the tools used.

The following picture shows the results of the first test done with pressure flaking.



Two slabs that were pressure flaked using an antler tipped Ishi stick are shown on the left. Two more slabs that were pressure flaked using a copper tipped Ishi stick are shown on the right. The slotted rubber/leather pad shown at the bottom was used to support the slabs in the left hand and allowed the flake to travel without interference. The flakes removed with both antler and copper were all elliptical in shape and only slightly longer than their width. I was unable to significantly increase the length to width ratio using copper or antler regardless of the direction or the amount of applied force.



This next picture shows the results of the 2<sup>nd</sup> test using percussion flaking.



The two slabs on the left were percussion flaked using antler. Those on the right were percussion flaked using solid copper. In both cases all of the flakes removed were elliptical in shape and similar to those removed with pressure flaking. Some of the flakes were slightly wider than their length which was mainly a result of the edge angle (platform) being nearly 90 degrees. These flakes feathered out along the sides and terminated a little short at the distal end. The lower left flake has a platform closer to about 60 degrees and the flake was nearly round in shape.

OK, so what does all this prove? Well, it seems that the type of tool used (copper or antler) as well as the method of removal (percussion or antler) have little impact on the shape of the flake removed! There may be some minor differences that I could not detect, but they are insignificant. Of course, this only applies to a flat surface which provides ideal conditions and repeatability. Is this knowledge of value when removing flakes from an irregular surface, such as a biface? I think it is. That is just my opinion, but the whole purpose of performing a test like this is to gain insight into what can be expected under typical conditions that are not perfect (the surfaces we encounter in bi-facial reduction). I'm going to make the assumption that the shape of a flake removed from any surface has little to do with the type of tool used (copper or antler) or the method of removal (percussion or pressure). Instead, I believe that the primary determining factors in the shape of any flake removed from any surface are primarily a result of the following.

1. The shape of the surface where the flake is to be removed. The flake will follow ridges if they exist and it will fan out on flat surfaces.
2. The point at which the pressure is applied (when pressure flaking) or the point of impact (when percussion flaking). This will determine the initial thickness of the flake as it begins its travel.
3. The amount of applied force. This factor affects the mass and shape of the flake removed. More force is required to initiate fracture as the platform depth is increased (or the depth below the surface at which the pressure flaker makes contact).
4. The direction of applied force, including both the depth (or downward) direction as well as the direction across the face of the bi-face whether it be at 90 degrees or diagonally.

All of these factors directly affect the final shape of the flake detached. The type of material used to initiate the fracture (copper or antler) is mostly a matter of personal preference. The copper will require a stronger more heavily ground platform than the softer antler. And, if a massive flake is to be removed, more force can be applied using percussion instead of pressure due to the strength limitations of the person applying the pressure. If a mechanical levering device is used to apply pressure (such as in fluting), the flake removed should resemble that done by percussion. Again, the flake removed is primarily a result of factors 1 thru 4 above.

The bottom line is the stone simply follows the laws of physics and reacts according to the forces being applied to it. You cannot force a flake on a flat surface to be much longer than its width. You can, however, cause the flake to terminate short by applying pressure (such as with you fingers) to the surface of the flake as it is traveling. This usually results in a step fracture. I have heard of some knappers who are able to extend flake length by applying pressure along either side of the flake as it travels but I am not familiar with this technique and did not try it. My guess is that the flake might terminate short along the sides but continue straight ahead. It would be interesting to see what others are able to do using this or other techniques, and I'd really like to hear from them.

One final picture:



Copyright © 2004 Jim Winn

---

From [http://www.flintknappers.com/oldsite/jim\\_winn\\_flat\\_surface.html](http://www.flintknappers.com/oldsite/jim_winn_flat_surface.html), April 8, 2010,  
copied with permission

# A Theory for Flake Creation

## A Status Report of Research Begun

### April, 1997

**Tony Baker**

December 21, 2003

[Note: Many of the figures in the online version of this paper are animated and they obviously will not be in this hard copy. Indeed many figures have been left out of this hard copy because they are not very informative in static mode. Readers are encouraged to see the online figures.]

#### **Introduction**

In April 1997, I became interested in the mechanics of flake creation. I purchased some mechanical engineering software in 1998, modified it for my purposes, and began attempting to understand flake creation. Subsequently, I wrote status reports about my work in November 1998, [September 1999](#), [March 2000](#), and [November 2001](#). Each report represented my understanding of flake creation at that writing. Each kept some ideas presented in the previous reports and, at the same time, contradicted some of the other ones. Such is the nature of discovery.

Until the fall of 2002, the only computer program that I was using in the research was the one I had purchased and modified in 1998. That program was a static model and, therefore, it only allowed me to investigate pressure flaking. I knew this, but since pressure and percussion flakes are so similar with the exception of size, I was not too concerned about it being only a static model. In the fall of 2002 Bill Watts, a colleague of mine from my Texaco years wrote a number of dynamic programs that allow me to start to investigate percussion flaking. In [September](#) of this year, I wrote another status report. Four days after going public with it, I realized there were some major errors in it. So, I quickly set out to correct those errors. I discovered it wasn't that easy. What I thought I could correct in two weeks took me three months. This is that corrected version.

To close this section, I want to thank Bob Patten, Andy Pelcin, and Bill Watts. Each of these individuals has been involved in this research almost since its inception.



this Figure.

**Figure 1** -- Edge view of a 1" by 1/4" thick biface that is firmly supported on the opposite edge from the platform or the bottom in

## Vibration of Cores

[Figure 1](#) represents a vertical, glass cantilever beam that is 1-inch long, 1/4-inch thick and firmly anchored on the bottom. (Click on [Figure 1](#) if you haven't previously done so.) This cantilever beam can be visualized as representing a 1-inch wide, 1/4-inch thick biface core that is firmly supported at the edge opposite from the platform. If a force is applied to the platform of the core, it will bend as shown in [Figure 2](#). In the real world this large amount of bending is impossible because glass is too brittle and will break. However, cores do bend when force is applied and the bending can be seen with magnification. Here the magnification is accomplished mathematically.

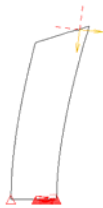

**Figure 2** -- Edge view of a 1" by 1/4" biface. Biface is bent because a perpendicular force is applied to the platform. The deflection is magnified 15,000 times.

When the force is slowly removed from the core, it returns to its unbent shape, which is depicted in [Figure 1](#). Again, [Figure 2](#) is the bent shape and [Figure 1](#) is the unbent or "at-rest-position" shape. If the force is removed instantaneously, the core will vibrate as in [Figure 3](#). This vibration is identical to that of a tuning fork or a pendulum of a grandfather clock. Clicking on [Figure 4](#) will cause the core to vibrate for only one [cycle](#). Click on [Figure 4](#) a few more times and watch the motion during one cycle. The thin, vertical black line in the middle of the [Figure](#) is the at-rest-position for the core. At the beginning of the cycle, the end of the core is on the right with no velocity. As it begins to move to the left and towards the at-rest-position it gains velocity. When it crosses the at-rest-position it has completed 1/4 of a cycle and is at maximum velocity. Past the at-rest-position, it begins to slow down as it continues to move to the left. At the far left, 1/2 cycle later, it stops and then begins moving back to the right, gaining velocity as it goes. Again as it crosses the at-rest-position, 3/4 cycle later, it is moving at its greatest velocity. Moving further to the right, it begins to slow down and finally stops at the far right and ends a single cycle. The time it takes this core to complete one cycle is 0.0004726 seconds, which is called the [period](#) of the vibration. Or, the core makes 2116 cycles in one second, which is its frequency. A frequency of 2116 cycles per second is well within the audible range of the human ear and, in fact, it lies within the range of the piano.

This [period](#) of the core does not vary with the amount of initial displacement. [Figure 5](#) compares the vibration of the core for two different initial displacements. As can be seen, the time of a complete [cycle](#) is the same even though the red starting position is about half that of the black. This is extremely important because this means that the velocity of the end of the core is faster for the larger initial displacement. A pendulum on a grandfather clock behaves the same way.

The period is independent of the displacement but the velocity is not. The period of the core is dependent on its shape, mass and material; removing flakes changes its shape and mass, and therefore its period. However, it does not change appreciably with the removal of a single flake so knappers are able to adjust their behavior gradually and subconsciously.

Pressure flaking is the application of a slowly increasing force. The force is applied so slowly that the entire core is able to bend or deflect in response to the gradually changing force. In different words, there are no inertia effects; the entire core and supports feel the pressure flaking force and respond to it. [Figure 2](#) is an example of a load applied by pressure flaking. The entire core has experienced the force and the entire core has been deflected. Additionally, the amount of deflection is related to the amount of force that is applied. The more force, the greater the deflection. This is evident in [Figure 5](#). The black response was created by mathematically applying a force twice that of the red response. It is the same core in each response.

So what determines how much force the knapper must apply to a core to initiate a crack when pressure flaking? Is it the muscles in his hands and legs? No, it is the platform. The [platform strength](#) determines how much force the knapper must apply to start a crack. If the strength is low, then little energy is added to the core and a short flake is the result. If the strength is high, abundant energy is added to the core and a long flake can result. Sometimes the platform strength is so high that the knapper can not overcome it and nothing happens.

[Platform strength](#) can vary for a number of reasons. If the platform is at an [off-margin](#) location, then it is stronger than a [margin](#) location. If the platform is on the margin, then platform preparation, such as grinding or polishing, determines its strength. Obviously, platform strength must not be too weak nor too strong, it must be just right. Therefore, it is one of several critical variables a knapper must manipulate while performing either pressure or percussion flaking. This is the reason Whittaker writes "platforms are the key to successful knapping" (1994:98). Patten concurs in his book with "preparing a stable platform is one of the most crucial skills a knapper can develop" (1999:39).

[Figure 6](#) is an animation of the core in [Figure 1](#) as the force is slowly applied to the platform. The force is applied at the location of the crosshairs and perpendicular to the platform face. The deflections are magnified 15,000 times. Click [Figure 6](#) a couple more times and watch the movement of the platform. Also, note that at the end of the animation, the entire length of the core is experiencing deflection and this deflection is energy added to the core.

As stated above, if the force is gradually increased to the magnitude of the [platform strength](#), then a crack initiates. In [Figure 7](#), the crack initiation animation has been added. After the crack begins to propagate, the force needed to continue to separate the core from the platform is extremely small compared to that required to initiate the crack. To simplify this theory of flake creation, I assume this separation force is zero and the core is free to vibrate at its natural frequency.<sup>1</sup> [Figure 8](#) depicts the creation of an entire flake with this assumption. Basically, the crack is propagated by the core pulling away from the platform. Click on [Figure 8](#) as many times as necessary to determine movement of the core and platform during the creation of this flake.

The movement of the platform during the creation of the flake in [Figure 8](#) is nil. This animation represents a rigid impactor or pressure tool, which means it does not move after the crack begins. This is an example of the crack being created with only the energy that is stored in the core. There is no additional energy or movement added by the impactor after the crack initiates.

With the previous assumptions of a separating force equal to zero and a rigid impactor, I can make a statement about the time it takes to make the flake or the speed of the crack. Notice in [Figure 8](#), the crack finishes at the same time as the core returns to the at-rest-position. The time interval from the beginning of vibration (initiation of the crack) to the core reaching the at-rest-position is  $\frac{1}{4}$  of the [period](#) (0.0004726 seconds) or 0.0001182 seconds. Since the core and therefore the crack are 1 inch long, dividing the length of 1 inch by 0.0001182 seconds can approximate the average velocity. This velocity is 215 meters per second.<sup>2</sup>

As stated above, a rigid impactor makes the flake in [Figure 8](#) because the platform never moves after the crack initiates. Rigid impactors do not exist in the real world and can only be created in the mathematical world as I have done here. In the real world, impactors deflect (compress) as they apply force to the core just as the core deflects when force is applied to it. When the crack initiates, the impactor tries to return to its at-rest-position just like the core does. The result is the impactor pushes the platform away from the core and helps to propagate the crack. [Figure 9](#) is an example of non-rigid, real world impactor creating a flake.

The only difference between the flake created in [Figure 8](#) and the one created in [Figure 9](#) is impactor stiffness. All the other parameters ( [angle of blow \(AOB\)](#), [platform angle](#), [platform strength](#), etc) are identical. [Figure 10](#) is an example of an impactor that is even less stiff than Figure 9, and again all the other parameters are the same. The flakes created in Figures 9 and 10 are [feather](#) flakes.<sup>3</sup> The reader probably has also noted that the more flexible the impactor, the shorter and thinner the resulting flakes and the larger the bulbs of force are. These observations are correct as long as none of the other parameters are changed. However, the knapper can change the angle of blow and create a full-length flake with either of the flexible impactors in Figures 9 or 10.

## Defining the Static and Dynamic Loading Modes

Energy can be applied to a core in the static mode or the dynamic mode. In the [Vibration of Cores](#) section, the entire discussion concerned the static mode. Pressure flaking is done in the static mode. Some percussion flaking is also performed in the static mode and some in the dynamic mode. So what is the difference between the two modes? How are they defined?

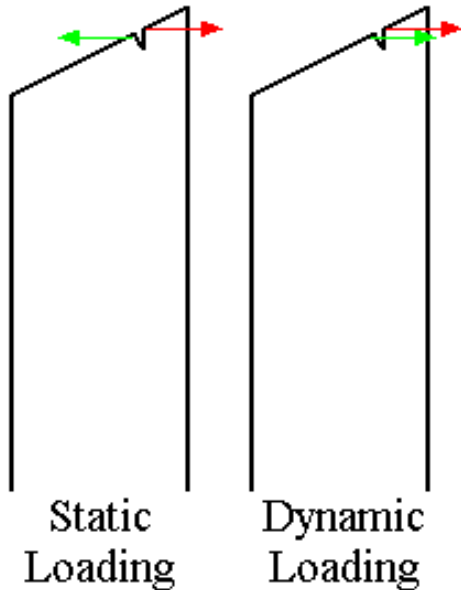

**Figure 11** -- The motion of the core (not the flake platform) after the crack begins to propagate defines the static and dynamic modes. In the **static mode**, the core starts immediately towards its at-rest-position (to the left) when the crack begins. This is a result of the loading time being greater than the period of the core. In the **dynamic mode**, the core has a velocity in the same direction the flake platform is moving and, therefore, it continues in this direction when the crack begins. However, it immediately starts to slow down and ultimately reverses its direction towards the at-rest-position. This is a result of the

loading time being less than or equal to the period.

The green arrows represent the direction of movement of the core at the time the crack begins. The red arrows are the direction of movement of the flake platform.

The answer to these questions can be seen in [Figure 11](#). Basically, the motion of the core, not the motion of the platform, at the time the crack begins to form defines the two modes. An immediate reversal of the core's direction toward the at-rest-position is static loading. If the core continues in the same direction after the crack starts, then it is dynamic loading. For animations of these motions see [Figure 12](#) for static loading, and [Figure 13](#) for dynamic loading.

The conditions necessary for each are:

**Static Loading Mode** -- [Loading time](#) is greater than the [period](#) of the core.

**Dynamic Loading Mode** -- Loading time is less than or equal to the period of the core.

The above definitions are based on the [loading time](#) of the core and its [period](#). That said, I would like to introduce [Figure 14](#) to further explore these modes. Figure 14 shows the loading regions for the 3" wide biface core in Figures [12](#) &



13. On the horizontal axis is loading time, which is part of the above definitions. However, the vertical axis is [width-to-thickness ratio](#) instead of period. I choose to use width-to-thickness ratio because it directly relates to the period and it is easier to comprehend. The period of a core is a function of its material composition (type of rock, which is constant) and its morphology (width and thickness). Since most knappers attempt to thin their cores while preserving the width, width-to-thickness ratio for a constant core width (in this case 3") is a good proxy for the core's period.

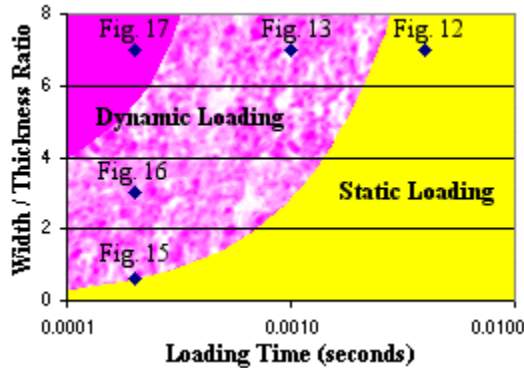

**Figure 14** -- The loading regions of a 3" wide biface. The yellow is the static mode region and the purple is the dynamic mode region. The dynamic region is further subdivided into lighter purple and darker purple. In the yellow and lighter purple regions all the flake types except the hinge flake can be created. The darker purple is the region of hinge flakes caused by the second

harmonic in the core's vibration.

I also wanted to use a more understandable proxy for loading time in [Figure 14](#), but I could not find one. Unlike the [period](#) of the core, which is only a function of the core, the [loading time](#) is a function of [platform strength](#), and the mass and stiffness of both the core and impactor. The knapper can't change the mass or stiffness of the core at any given stage, but he can definitely alter the platform strength. Additionally, he can change the mass and stiffness of the impactor. The most effective way to do this is to change the impactor's composition (rock, antler, bone, wood, etc.), size, and morphology (spherical, asymmetrical). To a lesser degree, the knapper can effect the impactor stiffness by varying the velocity of the blow and, in the case of asymmetrical impactors (billets), the attack angle can be altered.

[Figure 14](#) also refers to [Figures 15, 16, & 17](#), which are also cores with a width of 3 inches. However, their loading times are a constant 0.0002 seconds and their [width-to-thickness ratios](#) vary. With a loading time of 0.0002 seconds, it is very difficult to achieve static loading unless the core is extremely stiff. The core in [Figure 15](#) is in the static region. It is 5 inches thick, which is a width-to-thickness ratio of 0.6. Conditions that this might represent are the earliest stages at the quarry where large irregular chunks are being impacted with spherical rock hammers of similar size.

[Figure 16](#) represents a core a [width-to-thickness ratio](#) of 3 (1 inch thick) and is in the dynamic loading region. This width-to-thickness ratio is very common among the discarded cores at a quarry. Often these types are referred to as failures if one assumes they were on a reduction trajectory to becoming projectiles. (See [Contrasting the Lithic Technologies of Mesa and Folsom](#).) These are also created with rock impactors that have similar masses as the core.

[Figure 17](#) is the same core shown in [Figures 12 & 13](#), which has a [width-to-thickness ratio](#) of 7. However, the [loading time](#) is five times faster than [Figure 13](#), and 12 times faster than the core's period. The loading time is so fast in relation to the period that a strong, second harmonic has been introduced into the vibrating motion. Now the core actually reverses direction several times during its fundamental period of 0.00248 seconds. Click [Figure 17](#) several more times and notice these reversals. These reversals cause [hinge flakes](#), which are also very common at quarries because of the use of rock impactors. I will have more to say about hinge flakes in a later section.

### **Energy -- The Engine of Crack Propagation**

Flakes are created because there is energy stored in the core prior to the crack initiating. The more pre-crack energy stored, the larger the flake can be. [Figure 6](#) depicts the core bending prior to the crack initiating. This bending is the storing of the energy. Also, remember that [platform strength](#) determines when the crack initiates. As soon as the impactor force exceeds the platform strength, be it a pressure force or percussion force, the crack will start as it does in [Figure 7](#).

Three variables determine how much pre-crack energy is added. These are [platform strength](#), [loading time](#), and the core itself. Strong platforms add more pre-crack energy than do weak platforms. Loading times can cause increases or decreases in pre-crack energy. Other variables being equal, flexible cores acquire more pre-crack energy than stiff ones. So how do these variables relate to each other in a manner that can be understood?

I struggled with this problem for several years. Finally, one day when all the celestial bodies happened to align just right, I discovered [Figure 18](#), which is the normalized energy added to a core versus the normalized loading time. The two images in [Figure 18](#) are the same, except the lower image is an expanded view of the red box in the upper image. The horizontal axis is normalized loading time (NLT), which is [loading time](#) divided by the [period](#) of the core. The vertical axis is normalized energy (NE) added, which is the pre-crack energy added to the core divided by the pre-crack energy added if the platform was loaded by pressure flaking. [Figure 18](#) can be used for pressure and percussion. It can also be used for any size core that is supported on the far edge from the platform.<sup>4</sup> Finally, it applies to all [platform strengths](#).

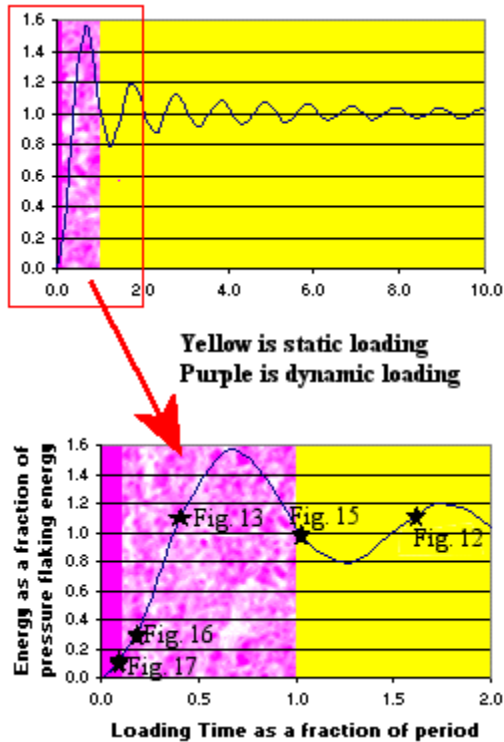

**Figure 18 -- Normalized Energy (NE) versus Normalized Loading Time (NLT) of a biface with a constant platform strength.**

A discussion of the curve in [Figure 18](#) is in order to understand further its significance. Let's begin far to the right of the top image at a NLT of 1000.0 or so. A NLT of 1000.0 is a [loading time](#) 1000.0 times longer than the [period](#) of the core. This is the region of pressure flaking and the NE curve is flat at a value of 1.0. And, it should be because the pre-crack energy added by pressure flaking and divided by the same value is 1.0. This is the definition of the NE.

Moving to the left or to lower values of NLT in [Figure 18](#), the NE curve begins to oscillate around the value of 1.0. At NLT around 10.0 this oscillation is between 0.97 and 1.03, which is insignificant in the knapping process. Continuing to lower values, the oscillating amplitude of the NE increases to significant values between 0.8 and 1.2 for NLT values between 1.0 and 2.0. At a NLT of 1.0, the NE is 1.0. Also, this is the transition between [static and dynamic loading](#).

Crossing into the dynamic region where the NLT is less than 1.0, the NE added to the core increases to the peak value of almost 1.6 in [Figure 18](#). This is 1.6 times the energy added during pressure flaking. This peak occurs at a NLT of 0.75. Then the NE curve starts to fall rapidly. It is back to 1.0 around a NLT of 0.5 and it is 0.0 and a NLT of 0.0

All the examples in [Figure 14](#) plot on the NE curve in [Figure 18](#). These five examples represent three different cores and three different loading times. Notice how [Figure 18](#) separates and accounts for all these conditions.

[Figure 18](#) is an explanation of the mathematical connection between pressure and percussion flaking. However, it can be misleading because the reader might think that percussion knapping occurs all along the NE curve. I don't believe this is the case. The knapping process begins at the quarry with a hard rock impactor and chunk of flakeable material. When I run values that represent these real world conditions in my computer programs, the percussion work always occurs at NLT values of 2.0 or less. I suggest that when the rankest rookie smashes two rocks together, the NLT is less than 2.0. The experienced knapper has learned to perform his knapping near a NLT of 0.75 with little variation from flake to flake. A NLT of 0.75 is the location of peak energy input into the core.

Removing each successive flake while maintaining a NLT of 0.75 is not easy, nor is it like shooting at a fixed target. Shooting at a fixed target requires the shooter to repeat everything exactly the same way from shot to shot. Flake removal is a moving target. It is a moving target because the [period](#) of the core is increasing as the core is becoming thinner. If the knapper repeats everything exactly the same way from blow to blow, he will be moving to the left in [Figure 18](#). His flakes will change to [step flakes](#) because he will progressively apply less and less energy to the core with each flake removal. To compensate the knapper slows down his blow, which slows his [loading time](#), and moves back toward the peak. However, ultimately the knapper will not be able to slow the blow any further because his impactor will have insufficient energy to exceed [platform strength](#) and initiate a crack.

The next thing the knapper does is subconsciously concede that he can no longer operate at peak energy input and increases his [angle of blow \(AOB\)](#), by moving the support or by selecting or creating a more acute [platform angle](#). This larger AOB will cause the flake to [feather](#) out just before the crack would have stopped in a [step](#) termination. Additionally, he will select or create stronger platforms so he can still get an acceptable size flake. The effect of these two changes is to create feather flakes with strongly wedge shaped cross-sections. If these wedge shaped flakes are acceptable to the knapper, he will continue until the NLT value drops below 0.10+ and then short, unacceptable [hinge flakes](#) start to occur. At this point the knapper generally abandons the core or switches to pressure knapping.

The important point in the above scenario is that the impactor was never changed. If the impactor had been changed to softer material, such as antler, bone or wood, then the core could have been further thinned. A soft impactor changes the NLT value significantly. If a knapper was to change from a hard rock impactor that is operating at NLT=0.75 to a soft impactor and hold all other parameters the same, the new NLT value would be greater than 0.75. In fact, I don't believe a soft impactor deployed against a quarry chunk with a [width-to-thickness ratio](#) of approximately 1.0 can be made to operate at the peak energy input of NLT=0.75. Only when the width-to-thickness ratio of the core becomes larger will the soft impactor begin to operate at the peak value. When the soft impactor is operating

at the peak, the hard rock impactor is making [steps](#) or [hinges](#) if all the other parameters were the same.

### **The Archaeological Record and Copper Impactors**

The archaeological record from large quarry sites contains many bifacial cores that are whole and fragmentary. It has been my observation that these cores, regardless of the quarry location around the world, have two common traits. They have [step](#) and/or [hinge](#) flake scars and they rarely exceed a [width-to-thickness ratio](#) of 4.5. These cores are a signature of a quarry and I define them as [quarry artifacts](#).

[Quarry artifacts](#) are the products of hard rock percussion on [off-margin platforms](#). As discussed above the knapper begins the reduction of a chunk or spall of lithic material with a hard impactor and the [NLT](#) is in the range of 0.75. This is maximum energy input. As the core is reduced, the knapper doesn't change his impactor and, therefore, the NLT is decreasing. As the process continues steps flakes and ultimately hinges flakes start to occur. At this point the [width-to-thickness ratio](#) is still below 4.5. The knapper could change to a soft impactor (antler billet) and continue to reduce the core, but instead he chooses to abandon the core. The reason is that lithic material and hard impactors are abundant. Soft impactors are not abundant, and they are high maintenance tools in that they have to be continually refurbished and often replaced.

Away from the quarry, lithic material has a much higher value to the knapper. Now, the knapper will employ a soft impactor and choose platforms on the [margin](#) to conserve lithic material. By using a soft impactor, he can raise the [NLT](#) and further thin the core without [step](#) and/or [hinge](#) flakes occurring. With some skill [width-to-thickness ratios](#) of 7.0+ can be achieved.

Many modern knappers use copper impactors for their percussion work. Copper is closer to hard rock than it is to antler or wood, and therefore its NLT's are closer to hard impactors. It will yield [step](#) and/or [hinge](#) flakes sooner than soft impactors. Therefore, to avoid steps and hinges, the copper knapper will switch to pressure at an earlier stage of reduction (smaller [width-to-thickness ratios](#)) than the soft impactor knapper.

### **Final Remarks**

The theory of flake creation presented in this web page has used biface cores in all the examples. This does not imply that it is not applicable to blade or other cores, because it is. The biface core is just a better textbook example because it passes through a wider range of flexibility than does the blade core. For example, I have observed that exhausted blade cores rarely exceed a [length-to-thickness ratio](#) of 2.0. However, as discussed previously, exhausted biface cores found at quarries ([the quarry artifact](#)) approach a [width-to-thickness ratio](#) of 4.5. Assuming that both blade and biface cores begin at a ratio of 1.0, bifaces are thinned twice as much as blade cores and, therefore, pass through a greater range of flexibility.<sup>5</sup>

Blade cores are so stiff in relation to the impactor that creating the second harmonic vibration in the core is almost impossible. That said, one would think it would be impossible to create hinge flakes on a blade core. However, look at [Figure 19](#). This is a blade core with three ugly hinge flake scars. This probably happened because a soft, billet impactor was used (Jacques Pelegrin, personal communication 2003). Unlike the biface/hard hammer collision where the biface is the flexible member, the blade core/billet impact has the billet as the flexible member. Therefore, the second harmonic responsible for the hinge flake occurs in the billet and not in the core. This occurs when the blade core's mass is decreased to the point that the knapper has to swing the billet faster than normal and hold the core tighter than normal in order to get significant energy into the core (Jacques Pelegrin, personal communication 2003). The [loading time](#) is reduced and ultimately hinge flakes will begin to occur as in Figure 19.



**Figure 19** -- A blade core with three hinge flake scars created by the vibration of the impactor. To create these hinge flakes, the impactor must be a long, narrow billet. The white arrows mark the termination of the hinge flakes.

The blade core in the image is from Les Maitreaux, a Solutrean quarry site in Central France.

Finally, the theory presented in this web page was derived from the output of several computer models, the archaeological record, and the products of the modern knapper. These three items had to be stitched together with logic and common sense and therefore, the theory may be partially or total incorrect. I sincerely hope someone attempts to test and challenge it.

### References

- Cotterell, Brain and Johan Kamminga  
1987 The Formation of Flakes. *American Antiquity* 52:675-708.
- Patten, Bob  
1999 *Old Tools--New Eyes: A Primal Primer of Flintknapping*. Stone Dagger Publications, Denver.
- Pelcin, Andrew W.  
1996 *Controlled Experiments in the Production of Flake Attributes*. Ph.D. Dissertation, Department of Anthropology, University of Pennsylvania, Philadelphia. University Microfilms, Ann Arbor.
- Whittaker, John C.  
1994 *Flintknapping: Making & Understanding Stone Tools*. University of Texas Press, Austin.

Van Peer, Philip

1992 *The Levallois Reduction Strategy*. Monographs in World Archaeology  
No. 13, Prehistory Press, Madison.

### Notes

<sup>1</sup> The assumption of a separation or propagation force of zero is obviously not correct because chemical bonds are broken as the crack is propagating and this requires the consumption of energy. However, after hundreds of FEA runs, it appears the energy to break the chemical bonds is very minute compared to the energy required to flex the core and overcome the [platform strength](#).

<sup>2</sup> The average speed of 215 meters per second is too large because the calculation assumes the vibrating core thickness does not change as the flake is made. This is obviously incorrect. Look again at [Figure 8](#). The flake being removed is reducing the 0.25-inch thick core to a thickness of 0.195 inches. This changes the period of the core vibration. A core that is uniformly 0.195 inches thick and 1 inch long will have a period of 0.0006059 seconds or about 30% longer. With this longer period, the average speed of the crack would be 168 meters per second. So the actual average speed of the crack in [Figure 8](#) lies between 168 and 215 meters per second.

<sup>3</sup> In Figures 8-10, the computer program was stopped just before the next movement would have separated the flakes from the cores. The computer magnification greatly distorts the images.

<sup>4</sup> Figure 18 was derived from a mathematical model of a cantilever beam. A cantilever is a beam that is supported on only one end. A diving board is a cantilever beam. The biface in [Figure 1](#) is a cantilever beam.

<sup>5</sup> Blade cores being thinned to only a [length-to-thickness ratio](#) of 2.0, while biface cores are thinned to a [width-to-thickness ratio](#) of 4.5, suggests that less rock is wasted at the quarry with biface cores. This contradicts the old adage that blades yield more edge per pound of rock than biface cores.

## Definitions from "A Theory for Flake Creation"

**Angle of Blow (AOB)** -- I measure the AOB from the "driving-nails-vector", which is a line through the platform and the support of the core. This AOB is different from the one used by most authors (Pelcin 1996:83, Whittaker 1994:94), which is measure from the platform face. The significance of this difference is when I write, "increasing the AOB" it would be "decreasing the AOB" in the nomenclature of the other authors.

The driving-nails-vector is defined as the direction of the force that will not rotate the core. It will only compress the core. On large cores where the inertia of the mass becomes the support for the core, then the driving-nails-vector would pass through the platform and the center-of-mass.

I measure from the driving-nails-vector instead of the platform face because it makes the AOB independent of the platform angle. By separating the two, I can investigate the effects of one while holding the other constant. I have found that AOB is the dominant variable of the two with regard to their effects on flake morphology. However, since AOB is not preserved in the archaeological record, then platform angle is a good proxy for it since most off-margin strikes are perpendicular to the platform face.

---

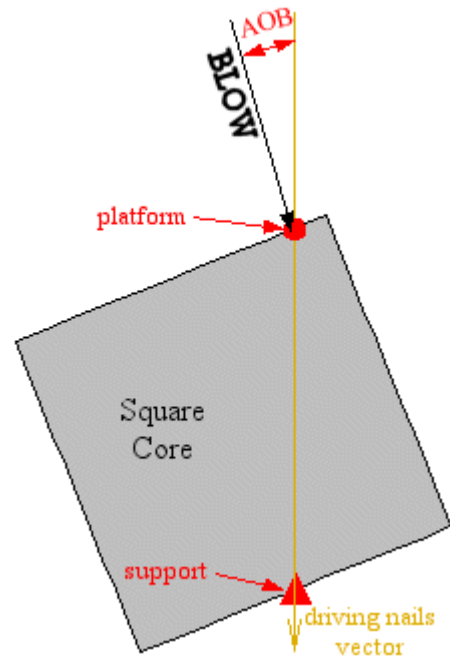



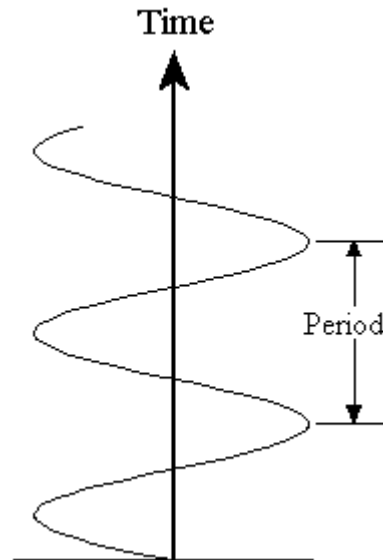

**Cycle** -- The motion that repeats itself in a vibrating system. A cycle is the vibration during the period.

**Flake Types** -- I recognize the four common flake types of feather, hinge, overshot (or reverse hinge), and step that are found in most of the literature (Cotterell and Kamminga 1987:684; Patten 1999:85; Whittaker 1994:18). Plus, I add the full-length flake for a total of five. These types are defined by their crack trajectory and termination and not by their initiation. Each, with the exception of the hinge flake, can be created with either pressure or percussion (soft or hard hammer). Each can have the universe of bulbs of force. And, each can initiate under the force application tool or away from it (lipped flake). The factors that effect the creation of the various flakes are width-to-thickness ratio of the core, loading time of the force, and angle of blow.

**Feather Flake** -- a flake created by a single crack with a straight trajectory that exits the front face of the core. Therefore, it is a fractional flake or is shorter than a full-length flake. When these flakes are removed from a flat face, they are wedge-shaped as in the image. The flake scars of these flakes can have some heavy ripples at the end, but the trajectory of the crack is still straight.

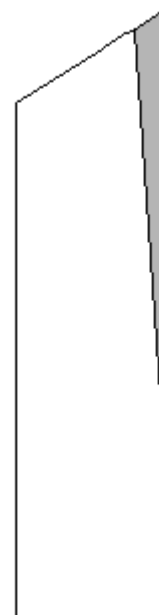

**Full-Length Flake** -- a flake created by a single crack with a straight trajectory that runs the full length of the core. As the crack approaches the far end of the core it will often turn, either toward front or back face, but it still exits the bottom of the core.

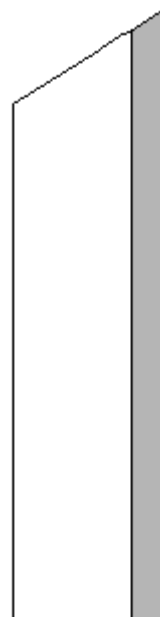

**Hinge Flake** -- a flake created by a single crack with a straight trajectory until it suddenly, but gently turns towards the front face and terminates the flake. It is a fractional flake or is shorter than a full-length flake. Often as the crack approaches the front face, but long after it has turned toward the front face, it will again turn either up or down. If it turns up it creates the classic lip (reflexed termination) that is associated with hinge flakes. If it turns down, then the flake scar (inflexed termination) is often assumed to be that of a feather flake with a jump in the scar surface. The hinge flake is the only flake that can not be created with pressure.

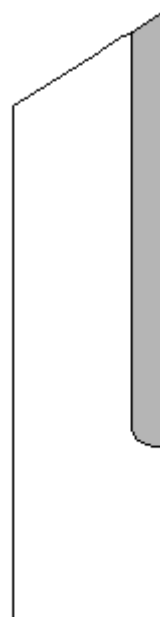

**Overshot Flake** -- or reverse hinge flake is created by a single crack with a straight trajectory until it suddenly, but gently turns towards the back face and terminates the flake. It has a trajectory that is the reverse of the hinge flake and hence, the second name "reverse hinge flake". It is a fractional flake or is shorter than a full-length flake.

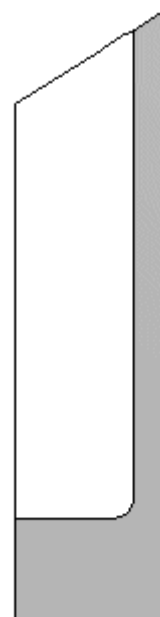

**Step Flake** -- a flake created by two cracks. The first crack is a straight trajectory that actually stops in the core because it consumes all the energy. When the first crack stops, a second crack caused by the knapper's follow-through breaks the flake off. It is a fractional flake or is shorter than a full-length flake. As in the drawing, evidence of the first crack extending beyond the end of the flake scar is almost always present because the second crack rarely begins at the very end of the first crack.

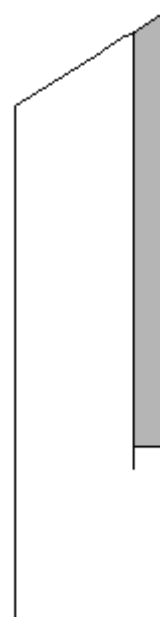

---

**Length-to-Thickness Ratio** -- Maximum length divided by maximum thickness.

---

**Loading Time** -- The force application time it takes to raise the force on the platform to the platform strength. I assume the force increases linearly with time until the crack initiates, which is symbolized by the red star. After the crack initiates, the force on the core (not the flake) drops to zero.

---

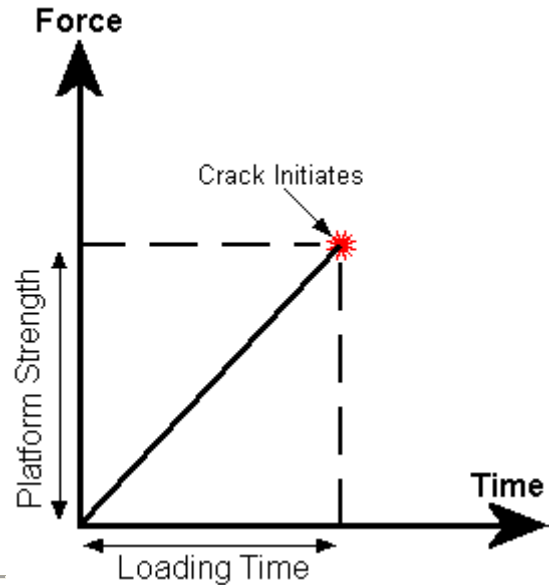

**Margin/Off-Margin Platform Locations** -- Off-margin (off-edge) platforms are located away from the edge. Margin platforms are located on the edge. The arrows mark the platforms on the almost identical two cores. The difference between the two is the margin has been moved (reduced) in the core on the right. Margin platforms are usually associated with soft hammer percussion and pressure flaking.

---

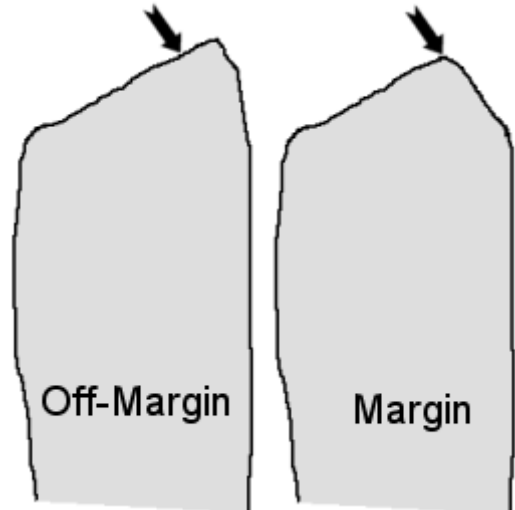

**Period** -- The time (usually measured in seconds) to complete one cycle of a vibrating system. The period is the reciprocal of the system's frequency.

---

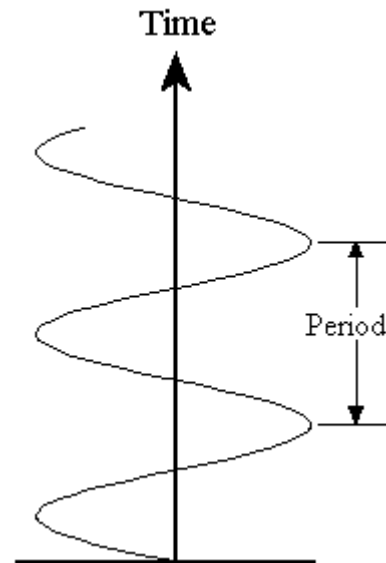

**Platform Angle** -- is the angle formed by the intersection of the platform face and the dorsal face of the core. See image "A". It is an easy variable to measure on a core and most research studies obtain this datum.

Platform angles are not as easy to measure on flakes. The flake in image "B" has an exaggerated reduced margin on the right edge of the image. Does one measure the angle between the platform face and the bevel that created the reduced margin or should one measured it from the true dorsal face? Image "C" is a flake created by a margin strike and the crack initiated at the point of impact, which removed all the platform face. Where does one measure the platform angle on this flake?

Most platform angles in the archaeological record range between 50 and 60 degrees regardless of time or space. For example, this range can be seen on Levallois cores (Van Peer 1992:24) or Folsom, channel flake preforms. When a platform is constructed (edge is turned) to remove flakes from a particular face of the core, it is done in a manner that minimizes the loss of the width or length dimension. The natural outcome of this minimizing effort is a platform angle between 50 and 60 degrees. Further support for this concept is the resharpening bevel on knives and points. These were hafted tools and the owner wanted to maximize their use life. So, they were beveled in a manner that minimizes the lost of material. The bevel on these tools is always between 50 and 60 degrees.

Many researchers have noticed relationships between platform angle and flake geometry. These same researchers also measure angle of blow (AOB) from the platform face, which couples the two variables (platform angle and AOB) and makes them dependent on each other. If angle of blow is measured independently of the platform face, the variation in flake geometry is a result of the angle of blow and not the platform angle. However, since AOB is not preserved in the archaeological record, then platform angle is a good proxy for it since most off-margin strikes are perpendicular to the platform face.

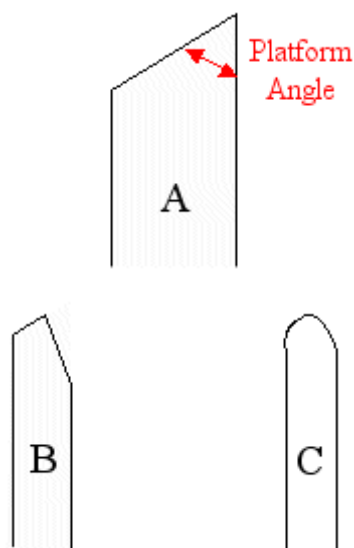

**Platform Strength** -- The force that must be applied to initiate a crack.

---

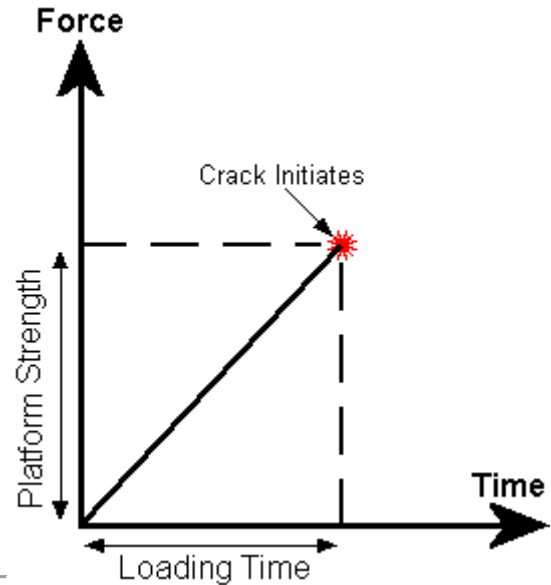

**Quarry Artifact** -- A bifacial artifact with step and/or hinge flake scars and a width-to-thickness ratio less than 4.5.

The biface fragment in the image is from an Archaic quarry in West Texas. The width-to-thickness ratio is 3.4 and the white arrows mark the termination of hinge flakes. It was purposely fragmented with a burin blow.



**Reduced Margin** -- See Margin/Off-Margin Platform Locations.

---

**Width-to-Thickness Ratio** -- Maximum width divided by maximum thickness.

---

From: [http://www.ele.net/algof/flake\\_creation/SD\\_text.htm](http://www.ele.net/algof/flake_creation/SD_text.htm), accessed 6/7/10, copied with permission

# The Ethical Responsibilities of Modern Flintknappers

Fisher, James V. (2003) "The Ethical Responsibilities of Modern Flintknappers". *The Authentic Artifact Collectors Association Newsletter*. Volume 1, Issue 3.

(© 2003, unauthorized reproduction prohibited.)

True or false: *All who engage in modern flintknapping are evil-minded con artists who intend to commit fraud, compromise the archaeological record, and complicate the market for authentic relics.* If you answered true then read no further. If you answered "false" then perhaps you are counted amongst the many collectors with a simple desire to try your own hand at making the types of stone tools you have been finding in fields and creek beds since childhood. You may also have answered "false" if you are one amongst many collectors of authentic relics who has developed an appreciation for the knowledge that can be gained through participation in modern lithic studies involving stone tool reproduction.

I believe that at one time or another most collectors of authentic relics have puzzled in admiration over the methods and techniques that our prehistoric American inhabitants employed to create such lithic treasures. A natural curiosity about the means by which projectile points were made often leads collectors to experimentation and involvement, at variant levels, with flintknapping. The purpose of this article is to offer some advice to collector/knappers that will help to ensure that your endeavors do not lead to further complications in the market for authentic relics, a compromise of the archaeological record, or indirect and unknowing involvement in a third-party transaction where a fellow collector has been subject to outright fraud.

Generally, flintknappers can be divided into three categories, commercial knappers, academic knappers, and hobby enthusiasts. For individuals who engage in flintknapping as either a hobby, academic, or commercial endeavor it should be understood that an ethical responsibility of the highest regard is warranted. I propose a maxim by which all modern flintknappers should abide: *I shall not engage in the production, sale, or trade of reproduction artifacts unless measures are taken to clearly identify and permanently mark them as modern reproductions.*

It is in the interest of setting apart modern reproductions from ancient authentic relics, that the phrase "*clearly identify and permanently mark*" comes to bear. Modern flintknappers must assume the ethical responsibility of taking reasonable measures and precautions that will ensure that the products of their activities are never co-mingled with, or presented as, authentic prehistoric artifacts. That task is far easier said than done. What follows are some suggestions for clearly identifying and permanently marking reproduction artifacts, whether you produced them or acquired them. If you are new to knapping or have not yet committed to marking your work on a regular basis, you might benefit from some additional, friendly advice on how to accomplish this effectively.

Just as serial numbers on guns can be eradicated, so can most attempts to "permanently" mark reproduction points on their surface. With that being said, a very effective, yet perhaps less widely accepted suggestion is for a hole to be drilled completely through a modern point with a diamond tipped drill. There is no argument that this would, in conjunction with additional

measures, clearly identify and permanently mark the reproduction as such. Even the most ethical and well-intended knappers (myself included) are not going to be thrilled about drilling a hole completely through their work. Many modern flintknappers and collectors of modern reproductions regard lithic creations and replica points as art and are hesitant to employ a method of clear identification and permanent marking that substantially detracts from the finished point.

What can and should we *reasonably* expect from modern flintknappers? I personally like the idea of using a diamond tipped scribe or high-speed diamond drill bit to mark reproduction pieces. It is as responsible and permanent an effort as can be reasonably expected. Signing (or initialing) and dating reproductions with a diamond scribe is best done nearer the center of a point where it would be more difficult to remove the mark via additional flaking. I also recommend placing additional markings on the point with permanent black pigment or India ink that has been subsequently coated with clear nail polish. It is not always easy to readily see signatures or markings made with diamond tipped scribes on certain lithic materials. The use of pigment ink will offer a second, more prominent marking that can make the overall effort of clear identification more effective. Individuals who sell modern points are encouraged to mark them with the phrase “Reproduction-For Study Only”. While this may not always be practical, particularly on smaller points, a simple “R” would likely suffice when accompanied by a diamond scribed signature (or initials) and the year of manufacture.

The next suggestions for ethical responsibility have more to do with what becomes of a modern reproduction after it has been clearly identified and permanently marked as such. It is imperative that if you choose to sell your modern work that you do so to individuals who can be trusted to continue the responsible custodianship that you have shown. In short, sell nothing to individuals whose motives for buying reproductions may be suspect. I have unfortunately known flintknappers who sold their reproductions to an unknown buyer only to find them listed in the “authentic artifacts” category on a popular online auction site. The modern points were quickly aged and presented as authentic by an unscrupulous dealer only days after they were obtained.

Modern knappers must also be concerned about those reproductions that will never leave their possession – during their life time. Non-commercial hobbyist knappers must also take reasonable steps to clearly identify and permanently mark their creations as modern. Keeping a meticulous record of reproductions in your collection complete with unique catalog numbers can help future heirs to easily distinguish modern reproductions from authentic ancient relics. All knappers must assume an ethical responsibility for clearly identifying and permanently marking creations that are sure to remain intact for countless generations to come.

Unfortunately, unethical knappers and fraudulent dealers will continue to flaunt any suggestions made concerning the management and identification of reproduction artifacts. The purpose of this treatise was to simply further the expectation that all ethical individuals who are involved with modern flintknapping will do their part to ensure the long-term viability of the authentic artifact collecting hobby and the integrity of the archaeological record.

---

From <http://www.creeksideartifacts.com/Ethics/knappingethics.htm>, March 31, 2010, copied with permission



# FLINTKNAPPING AND SILICOSIS

by J. Kalin (originally published in Flintknappers' Exchange 4(2): 1981)

## Introduction

Could early man have been a victim of an industrial disease?

I believe this to have been the case.

Flintknapping, an activity that dominated more than 99% of the archaeological record of human evolution, turns out to be potentially dangerous to the health of the flintknappers. The process, which involves the breaking of siliceous rocks, produces a fine dust. Repeated inhalation of the free silica particles ( $\text{SiO}_2$ ) can lead to a pneumonic condition called silicosis or fibrosis. This problem has also been noted by workers in mining, sandblasting, stone carving, road construction and ceramics, where silica is a major cause of pneumoconiosis or occupational lung disease (Agrecola 1557; Arlidge 1882; Collis 1915; Hunter 1978; Middleton 1930; Oliver 1902 and 1916; Ramazzini 1713; Severo 1980). Prolonged exposure to silica dust particles increases the chance of developing severe silicosis. When microscopic particles are inhaled they pass into the lungs by way of the trachea branching into the two main bronchi. The bronchi, in turn, branch into many tubes which continue to branch repeatedly until each finally terminates in an elongated saccule, the alveolar duct. Branching off this saccule are millions of tiny globular sacs or alveoli. The openings into these sacs are very small, about 5-10 microns. It is in the alveoli that gas exchange takes place with the blood. Our lungs contain approximately 750 million alveoli, which explains why the interior surface area of our lungs is more than fifty times that of the skin of our bodies.

Our bodies provide a defense of filters to protect our lungs. The hairs and sinuses of the nose catch the initial dust. The trachea and the larger branches of the bronchial tubes are covered with mucous cells and cilia which protect and clean the lungs of the finer particles. Mucous traps the particles while the beating of the cilia removes dust-laden mucous from the lungs.

Problems arise because silicates can break into very small particles, much smaller than 20 microns. These minute flakes enter the deepest part of the lungs, past the mucous and cilia cells in the bronchae and continue until they reach the alveoli, or air transfer sacs. Once these flakes become lodged in the alveoli, they cannot be removed by the lung's natural defense mechanism.

The condition becomes more and more serious as the alveoli fill up with razor sharp particles, although the effect is often not felt for many years (usually after 10 to 25 years according to Plunkett, 1976, and 20 to 30 years according to Berkow, 1977).

## How Silicosis Develops

Silicosis develops through three recognizable phases (Hunter, 1978; Middleton, 1930). In the beginning the most important symptom is a slight difficulty in breathing which becomes apparent after exertion, increasing in severity as the condition progresses. A cough may also develop, which is usually "dry", with little mucous. Generally, because of the gradualness of the process, individuals feel little immediate effect from the changes taking place in their lungs. Fibrous tissue develops around the dust laden cells and forms small round nodules, several millimeters in diameter. These become a permanent part of the lung tissues and are visible by x-ray analysis.

Coughing and shortness of breath become noticeable in the next stage. Nodules increase in size and number, occasionally lumping together into conglomerates. Sounds can sometimes be heard in the lungs. A reduced chest expansion, high blood pressure and noticeable effects on working ability are also symptomatic.

During the final stage, the debilitating effects of the condition are accentuated nodular development, emphysema, and x-ray evidence of growing fibrous masses of tissue. These cause extensive incapacitation of the victim and may ultimately result in death.

In addition to the lacerating sharpness of the tiny flakes, a chemical reaction must take place for silicosis to occur (Hunter 1978; Kettle 1932). A soluble substance called silicic acid dissolves off the surface of the stone and polymerizes when it is neutralized by the body tissue. (In polymerization, molecules combine to form long chain compounds of a high molecular weight. This type of reaction is used to make polyethylene or common plastic.) During its creation, polysilicic acid poisons the surrounding tissues. The affected cells appear to be mummified and do not decompose as dead cells in the lungs normally do. What makes flint and quartz particles among the most dangerous of all mineral dusts is the extent to which they dissolve into the blood plasma and the low pH of the acid produced (Hunter 1978). The fibrosis is caused by a poorly understood reaction from the interaction of silica by-products with lung macrophages or defense cells (Cullen 1980). This can be illustrated by comparing flint dust to cement dust which is also high in silicic acid. The high alkaline pH of the limestone in the cement neutralizes the acid and renders it harmless before it reaches the blood plasma and body tissues (Hunter, 1978).

## Types Of Quartz

Some types of quartz dust are more dangerous to inhale than others (Cullen 1980; Stober 1966). There are three major types of silica deposits which constitute the majority of knappable stones: Amorphous, common quartz crystal and cristobalite. Cristobalite is a cubic crystal that forms at high temperatures and is less prevalent than amorphous and common quartz. A fourth type, tridymite, is rare and only encountered in minute traces.

The least dangerous, but by no means safe, is the amorphous type which is a quick cooling, crystal free variety. Glass, obsidian and opal are examples of amorphous quartz.

Common quartz and quartzite are examples of quartz crystal. Also included in this group are chalcedony, flint, jasper, and chert, all of which are microcrystalline and possess microscopic needle or fiber-like quartz crystals, often arranged in fan-like structures.

### Composition Of Flint

Most flints are composed of 98% silica with 1% to 2% water and minute quantities of impurities which cause color variation. The water appears to be responsible for the exceptional tensile strength of the material (Shepherd 1972). The needle-like, microcrystals of quartz may vary in size and shape from the shorter, stouter type, like those in Irish gray flint, to the long slender crystals found in English black flint. Not all flints are common quartz. Amorphous quartz, cristobalite and tridymite may occur adventitiously also. In Danish flint, which is visually similar to English flint, common quartz was found to range between 4% and 100%. The remainder of its composition was made up of cristobalite, glassy quartz, or a mixture of the two (Shepherd 1972). Traces of tridymite were also found in several samples. Cristobalite has proven to be the most dangerous of the silica dust and workers exposed to cristobalite display a higher incidence of silicosis (Cullen 1980). Cristobalite may also be found in rhyolite, bentonite, obsidian crystal pockets, high fired ceramics, and basalt.

### Diagnosis Of Silicosis

Silicosis is easy to diagnose in its early stages by x-ray and the individual can take appropriate steps to avoid the debilitating and irreversible effects of the advanced stages. An obvious step is to stop exposure to silica dust. Continued exposure will aggravate one's silicosis condition, but there is a difference of opinion as to what happens when a person with silicosis symptoms is no longer exposed to silica dust. In severe cases, it appears the disease does not arrest itself. However, evidence from several studies in England show that when people with early silicosis discontinue their exposure to silica dust, either the disease does not progress, or its development is retarded for a considerable number of years (Middleton 1930; Board of Trade 1945).

### Additional Complications

Curiously, rheumatoid arthritis sufferers show a high rate of incidence of previous exposure to silica dust. This may be explained because silica-laden white blood cells often re-enter the blood stream from the lungs and thereby transport particles to other lymphatic areas of the body (Cullen 1980). In 1885 Arnold found silica particles included in the liver, the spleen and bone marrow (Arnold 1885). Cuts from knapping may also leave slivers of stone in the body.

It also appears that smoking increases the danger of silicosis. Be it today, or in ancient times in the New World, nicotine paralyzes the cilia and prevents the natural cleansing of the bronchial tubes, which results in the bigger flakes being retained.

Carving soapstone may cause mesothelioma (a cancerous lung disease) due to the asbestos fibers in the stone. While silicosis and cancer are found together, there is no proven evidence that silica is a carcinogen (Hunter 1978). In the last year or two, some evidence suggesting silica related cancer has been emerging (Cullen 1980).

Ironically, even black lung disease, common among coal miners, is attributed not so much to the coal itself, but to the silica dust present in the coal (Shottenfield 1980).

Tuberculosis often accompanies silicosis and the result is a devastating combination. Since it is the most frequently associated complication, tuberculosis plays an important role in silicosis history (Hunter 1978).

Capable of infecting other animals (cows, for example) as well as humans, the roots of tuberculosis have been traced back thousands of years in Africa, Asia, Europe, and North and South America. Examples of tubercular disease and deformation have been identified through autopsies of ancient mummies, "deformed bones (Potts disease) and may be seen depicted in examples of prehistoric art work (Brothwell 1968; C. Wells 1966; Ritchie 1952). Silicosis has been identified in mummies from Egypt (Harris 1978) and Peru.

It is very difficult to differentiate between silicosis and tuberculosis by x-ray alone, and diagnosis should not be made unless additional tests are run. Even in autopsy, the two lung diseases tend to obscure one another, making diagnosis very difficult (Hunter 1978).

TABLE I  
RELATIONSHIP OF DEATHS FROM TUBERCULOSIS  
TO QUARTZ CONTENT OF DUST\*

OCCUPATION	QUARTZ CONTENT OF DUST	PERCENT DEATHS FROM PULMONARY TUBERCULOSIS
FLINTKNAPPERS		
(Brandon, Eng.)	100%	77.8%
GRINDERS		
(Sheffield, Eng.)	50% - 100%	49.7%
GRANITE- CUTTERS		
(Maine and NH)	30%	47.8%
POTTERS		
(Certain Processes Only)	28%	18.9%
COAL MINERS	--	9.8%

\* After Collis

There is a direct relationship between the silica content of and industrial dust and workers' deaths from pulmonary tuberculosis. The 1913 study by Dr. E. Collis showed that over three quarters of the flintknappers at Brandon, England died of this problem. He was able to show that workers with silicosis are more prone to contracting tuberculosis and more susceptible to infections from other types of pathogens. Even relatively harmless dusts, when inhaled by a person with mild silicosis, may create a potentially serious pneumoconiosis condition (Collis

1913). His research concluded that the more different a substance is from those of which the body is naturally composed, the more injurious it is to the body.

In light of this information, how can we flintknappers protect ourselves from these dangers?

### The Dangers Of Working Indoors

In 1930, Middleton measured the atmospheric dust produced by two flintknappers working in a shed. His findings showed concentrations as high as 1,313 particles per cubic centimeter, with the majority of the flakes under 1 micron in size. Only 2% of these tiny flakes were over 2 microns. These minute particles easily enter the 20 micron alveolar sacs of the lungs, making silicosis complications from flintknapping understandable. Remembering that a micron is only one thousandth of a millimeter helps you visualize how small these flakes actually are. By definition, particles smaller than 1 micron cease to be called dust and are classified as fumes and those smaller than .3 of a micron are listed as smoke. Imagine the particle counts at a modern indoor knap-in. Errett Callahan spoke of seeing clouds of dust at the Flintknappers' Exchange 1979 Knap-in at Casper, Wyoming (E. Callahan 1980).

During the winter I maintain an indoor workshop in the basement of my house. Since the ventilation is poor, I now wear a respirator while working. The Mine Safety Appliances Company in Pittsburg, Pennsylvania makes a mask for dust and fumes that does the job, It is a COMFO 2, custom respirator with a filter cartridge for asbestos-containing dusts, fumes, and mists. While no filter gets everything, the filter meets Mine Safety and Health Administration (MSHA) and National Institute for Occupational Safety and Health (NIOSH) safety requirements. A mask with dual filter cartridges should cost about \$20. The cartridges may be used until they become clogged with dust before changing, but care must be taken not to let the interior of the mask become contaminated with silica dust when it is not being used. To prevent this, I fasten plastic sandwich bags around the cartridges with rubber bands. Be sure to wear your mask while sweeping up debris. When working indoors, remember it takes over a half an hour for suspended silica dust and fumes to settle (Middleton 1930).

An exhaust fan will also prove useful when working indoors.

Clothes worn while knapping should be changed, or at least brushed off, after working to avoid tracking dust into living and sleeping areas. Another possibility would be some type of knapping apron to protect clothing from dust. Use of a particle ionizer will also reduce exposure to small particles (electrostatic precipitator).

### Working Outdoors

Unless a wind is present, I try to wear a mask while working outdoors, especially when the work is very dusty. When working without a mask, I try to sit so that the wind aids in dust removal. I also try consciously to time my breathing to avoid inhaling the clouds of dust I have just produced, whether from quarrying the stone or finishing a biface with pressure. Fine dust forms whenever the stone is broken. For example, I have found that my platform preparation technique of shearing/abrading tends to produce a lot of visible dust. This can easily be seen

when viewed by a strong side light against a dark background. You will notice that while the tiny flakes fall to the ground, a smoke-like powder floats upward, where it is easily inhaled/ Because of this, when I work without a mask, I try to avoid inhaling whenever I see dust while abrading. I hold my breath or slowly exhale, blowing a fine stream of air across my platform. This helps to get the dust away from me so it can be dispersed and removed by air currents.

Incidentally, most of the disposable dust masks for sale in hardware and paint stores provide only limited protection and are inadequate for filtering the suspended silica dust and fumes produced by knapping.

### Historic

Silicosis is the oldest ~known occupational lung disease (Berkow 1977). Historically, the use of dust masks for flintknapping begins in Brandon, England, where gun-flint knappers wore sponges tied under their noses in an effort to prevent the devastating effects of Phthisis or "knappers rot" (Shepherd 1972). Historically the flintknappers of Brandon, England, still a knapping center, suffered a high mortality rate from silicosis, often with tubercular complications (Collis 1913, 1915). Working mostly in sheds, skilled knappers, who could make three thousand gun flints a day (Webb 1911), were not expected to live much more than forty years (Collis 1913 and 1915; Middleton 1930; Shepherd 1972). The Table (Table II) by Edgar Collis, Medical Inspector for Factories in England, shows the death rate for Brandon Flintknappers. We are most indebted to him for his research.

Notice that wives of flintknappers and others not engaged in the profession were not affected by silicosis and had normal life spans. Agrecola (1557) noted that wives of Carpathian miners had as many as seven husbands, due to the high mortality rate among the miners from silicosis.

In the "Minutes of Evidence", Collis describes in detail several of the flintknapping families. At the time the study was made, in one family of twenty-six persons (thirteen males and thirteen females), twelve of the males had been flintknappers and ten of them had died. This left two flintknappers and the one 'non-flintknapping male alive, while all thirteen of the women were still alive. In another family of six males, three became flintknappers, Two died leaving one flintknapper and three non-flintknappers alive. In a third family, two of the six males became flintknappers, and only one was still alive to join all four of the non-flintknapping males still living. Collis concluded by saying, "Despite the size of this small industry, there is an excessive mortality problem,"

In modern Brandon, Mr. Fred Avery, the last of Brandon's flintknappers, said that in an effort to avoid silicosis, he tries to work in a well-ventilated room and limits his knapping to 1-1/2 hours per day. Avery said that because of the historic instances of silicosis and its recorded high mortality, parents in the town discouraged their children from learning to knap (Gould 1980).

In France, among the people of the town of Meusenes, the gun-flint industry produced results similar to those at Brandon, England. Chateauneuf said, "By a fate, which seems connected with all that concerns the art of war, this industry slays those who follow it; it kills them before their time; for them there is no old age." When asked the cause of so premature a mortality,

doctors and officials gave the same reply-pulmonary phthisis induced by prolonged inhalation of dust generated from working flints" (Collis 1915).

T A B L E II  
COMPARING THE MORTALITY FROM PHTHISIS OF FLINTKNAPPERS  
WITH THAT OF CERTAIN OTHER CLASSES\*

	CAUSE OF DEATH, STATED AS PERCENT AGES FROM				TOTAL DEATHS	AVERAGE AGE	DEATH RATE PHTHISIS
	ALL CAUSES	PHTHISIS	RESPIRATORY OTHER THAN PHTHISIS	ALL OTHER CAUSES			
FLINT - KNAPPERS	100.0	77.8	7.4	14.8	27	46	41.0
WIVES (2) AND WIDOWS (11) OF KNAPPERS	100.0	0.0	15.4	84.6	13	78	0.0
BRANDON RURAL <sup>3</sup> DISTRICT	100.0	6.5	11.7	81.8	63		0.8
ALL MALES <sup>4</sup> (ENGLAND AND WALES)	100.0	11.2	17.6	71.2	509,567	Median 56-57	1.6

1. Death rate from Phthisis per annum among 1,000 living.
2. Average number employed for 25 years estimated at 16.5.
3. The figures for this class supplied by Dr. A. Harris, M.O.H., Thetford, Norfolk, are for all ages, 1901-1910.
4. The figures for this class, calculated from the Supplement to the Sixty-Fifth Annual Report of the Registrar General for all males aged 15 upwards, 1900-1902.

The average age at death of the 21 flint knappers who died from phthisis was 42.3 years, which is rather higher than the median age at death - between 39 and 40 - of all males dying from phthisis. The immunity of wives and widows of flint workers (see Table II) is also found among the families and relations.

Conclusion - as far as this small industry is concerned, exposure to fine dust of pure silica causes an excess mortality from phthisis, not found in the neighborhood in which the industry is carried on, nor among workers' relatives who do not carry on the industry.

E. Collis, M.B. H.B.  
MEDICAL INSPECTION  
OF FACTORIES

\*From the Royal Commission Report on Metalliferous Mines and Quarries, 1914, page 262 Appendix J.

Industrialization is probably responsible for these problems among the gun flintknappers, for it is from the continued exposure to silica dust that most cases of silicosis occur. If this is so, one would expect that this early industrial disease extended back into the Paleolithic period (Brothwell 1968; Wells 1964; Brothwell and Higgs 1969). Archaeologically; it might be possible to identify it in burials by analysis of the silica content in the dirt in the chest cavity compared to the surrounding soil. Biopsies of lung tissue in mummies could provide valuable data (Harris 1978). By Neolithic times extensive flint mining operations were taking place in northern Europe, and flints were dug and worked by the ton (Bosch 1979). Much of this flint went into making axes, which were often pecked and ground smooth for completion. These processes, if done without water, would produce excessive quantities of dust. Also, if water had been used and then was permitted to dry in the work area, it would allow flint dust to become airborne.

Thomas Benson, who in 1713 invented a method for wet grinding flints, states in the patent that the process of dry grinding "proved very destructive to mankind insomuch that a person ever so healthful or strong, working in that business, cannot possibly survive over two years,

occasioned by the dust sucked into his body by the air he breathes" (Royal Commission, Vol. 1, Pg. 134).

### Other Causes of Silicosis

While industrialized production of stone implements took place in different societies, not all silica workers could be considered flintknappers. Great numbers of craftsmen were exposed to dust as they carved out monumental statues and other constructions. In 1869, Hugo Millers wrote, "The mason is almost always a silent man; the strain on his respiration is too great when he is actively employed to leave the necessary freedom to the organs of speech" (Royal Commission, Vol. 11914).

Exposure to volcanic dust after eruption may also cause silicosis. The effects of exposure to high silica ash from Mt. St. Helens should become evident in the coming years (Severo 1980). Throughout time, volcanic eruptions covered different areas of the world with huge amounts of high silica ash. In some places the ash fall was so great that it buried whole cities, such as Pompeii or Thera, or caused entire populations to move, such as the Maya (Trotter 1977).

Silicosis also affected workers in the ceramic industry (Arlidgc 1892; Oliver 1902 and 1906). Flint glazes, mixing dry clay and sweeping up the powdery residues are probably the most dangerous activities.

In PreColumbian Mexico and Central America and in the Middle East, large specialized knapping centers developed to serve the elaborate obsidian trade networks that traded blades, bi-faces and ground stone objects. Through chemical-stone analysis it has been possible to trace how specialized craftsmen work daily in special quarry towns to make tools for people hundreds of miles away (Flannery 1976; Dixon 1968). In both these areas of the world, industrial stone knapping still exists today. For example, in the town of Teotihuacan, just north of Mexico City, craftsmen make percussion flaked spear points (projectiles) and carefully carved and polished obsidian objects. These are decorative rather than functional products, manufactured for the tourist market which has carried many of these items as far as Europe, Australia, and Asia (personal observation).

Stone tool making on a functional basis can be seen today in northwestern Turkey. Here professional flintknappers make direct percussion blades used in threshing sledges during the wheat harvest. A good knapper can manufacture almost 500 pounds of blades a day if the flint has been quarried beforehand. A village can produce about 500 tons a year. The blades are sold to merchants who distribute them throughout the country (Bordaz 1968).

Clearly, in these specialized occupations, workers are exposed to excessive quantities of silica dust and occupational lung disease could result. I am unaware of any medical study that has been done on the flintknappers of Turkey or the obsidian workers of present day Mexico, but these would be prime groups to investigate for signs of pneumoconiosis.

Today, unfortunately, many of us find ourselves in a similar situations as we work daily making lithic artifactual replications and the like. Whether for scientific research, pleasure, or



commercial production, we have become industrial craftsmen who subject ourselves to excessive amounts of silica dust and the inherent dangers.

The questionnaire which follows is an attempt for all of us to find out more about ourselves and flintknapping. Once the data is compiled, the results will be made available in a future issue of Flintknappers' Exchange. The Brandon history need not repeat itself today. By increasing our understanding and awareness of these potential hazards, we should be able to take appropriate steps to protect ourselves against unnecessary pulmonary damage.

### Summary

Silicosis is caused by the life-long exposure to and accumulation of free silica dust ( $\text{SiO}_2$ ) in the lungs. Its degree of severity appears to be directly related to density, length of exposure, particle size and type of quartz. The effects are often not felt until many years after exposure. The best way to prevent silicosis is to minimize the inhalation of suspended silica dust. While knapping, this may be accomplished by working outdoors and by wearing a respirator mask. If you are an avid knapper, a respirator would be an important part of your tool kit. Even if you only wear your mask for the more dusty operations, every little bit helps. When working without a mask, try to time your breathing to avoid inhaling the dust. Changing or brushing off your clothes after knapping may also prove useful. Where possible, water should be used when grinding silicates.

It is strongly recommended that knapping not be done indoors or in poorly ventilated areas unless a respirator is worn.

The last few issues of Flintknappers' Exchange (Volumes 3:1 and 3:2) showed pictures of indoor flintworking with windows shut. In many ways this simulates a prehistoric mining operation, lots of dust and little ventilation, and may be considered very unhealthy and dangerous. Realizing that health problems can arise from flintknapping is only half the battle. We must each take responsibility for taking precautions and changing old habits, to protect our own lives and the lives of those whom we introduce to the art. By taking the necessary precautions, we will be able to continue knapping to a ripe old age, free from the fear of silicosis.

I wish to express my appreciation to Errett Callahan, Mark Cullen and Denise Tratolatis for their generous efforts in making this paper possible.

## Bibliography

Agrecola, G., 1557 De Re Metallica. Froben Basil

Arlidge, J.T., 1892 The Hygiene Diseases and Mortality of Occupations. Percival and Company, London.

Arnold, J., 1885 Staubinhalation und Staubmetastase. Berlin, Germany.

Berkow, R., 1977 The Merck Manual. Merck and Company, Rahway, New Jersey.

Board of Trade, 1945 Provision of Employment in South Wales for Persons Suspended From Mining Industry 0~1 Account of Silicosis and Pneumonociosis. Board of Trade, His Majesty's Stationary Office, London.

Bordaz, J., 1969 "Flint-Flaking'in Turkey." Natural History Magazine, 78:73-79.

Bordaz, J., 1971 Tools of the Old and New Stone Age. Natural History Press, Garden City, N.Y.

Bosch, P.I., 1979 "A Neolithic Flint Mine." Scientific American, 240(6):126-132.

Brothwell, D., 1968 The Skeletal Biology of Earlier Human Populations. Pergamon Press Ltd., London, England.

Brothwell, D. and Higgs, E., 1969 Science in Archaeology. Praeger Publishing, Inc. New York, New York.

Callahan, E., 1980 Personal Communication.

Collis, E., 1913 Annual Report of the Chief Inspector of Factories .

Collis, E., 1915 Public Health, Volume 28, pp 252-264.

Cullen, M., 1980 Personal Communication.

---

from: [http://pugetsoundknappers.com/interesting\\_stuff](http://pugetsoundknappers.com/interesting_stuff), accessed 10-11-10



*Gary Abbatee's tool kit, used with permission*

## **Section 2: Tools**

# What Do You Really Need To Start Flintknapping?

*Wyatt R. Knapp © copyright 2003.*

I've been involved with flintknapping for some time now. I've been through a lot of searching and tool testing. If I've learned one thing it's that **there is no magic tool**. Don't fool yourself by thinking, "Oh, if I only had the tool that so and so uses I'd be able to flintknap." Or, "there must be some tool that makes this simple." Let me tell you, if there was a trick to it that made it easy then everyone would be doing it and it wouldn't be a big deal. Now, come over here and let me whisper the secret of flintknapping success into your ear. Ready? Okay ... **you have to do it a lot**. You have to practice and go through lots of material. And keep trying. You will learn and get better. I promise.

Now, after all these years I feel confident that I can give some good advice on what tools you absolutely need to be a good traditional style knapper. Don't collect a big old bucket of expensive tools and gadgets unless you like that sort of thing. Here's all you really need:

1. A leather pad of thick leather to protect your hand when pressure flaking.
2. A deer antler tine pressure flaker (or a copper tipped one as shown below). Antler tines work very nicely. They wear faster than copper but you get great pressure flakes. If you learn percussion work well, you will only need the pressure flakers for final edge sharpening and retouch anyway.
3. A medium sized antler baton, about 8 inches or so long and about 2 inches across at the business end. Make sure it is a good dense one. Antler is NOT harder to use than copper boppers. Knapping is not easier with copper. It is just as easy to learn to knap with traditional tools than it is with copper billets and such. Try the abo way.
4. A few hammerstones of various sizes. Quartzite or some other hard stone of a nice egg shape. One about 1 1/2 inches long, one about 2 1/2 inches. Also you can add a couple of sandstone ones that will be able to be used on easier material like obsidian or glass. You can usually find hammerstones by gravel pits, the lake shore, etc.
5. An abrader. Either of hard sandstone or a manufactured one.
6. A large thick leather pad to protect your leg while knapping.
7. A notcher. Make it from a cow rib bone, or an antler tine, or make a copper tipped one.

Now you will notice that of all those things, there is only one that would probably constitute a major purchase. That would be the moose antler baton. Prices for good antler batons can vary and there are deals out there. Just make sure the one you choose is good and hard, and dense.

The rest of the stuff on our list can be obtained cheaply, made yourself, or found for free.

These are the only tools you really need in order to flintknape and I have found that these are the ones I rely on over and over again. They could fit in a shaving bag or could be rolled up into a small leather parfleche and take up hardly any room at all.

Later on you may find that once in a long while you'll have need of a larger billet for spalling or something, but hey -- try a rock. They're free and lots of aboriginal knappers used them. I think there was probably a lot more hammerstone knappers than we realize in prehistoric times. With practice you'll be surprised how well you can remove flakes with stone tools.

Bottom line: You don't have to break your bank account trying to buy every new tool under the sun in order to turn out beautiful points. Do it the aboriginal way!

#### A Broomhandle Pressure flaker

Take an old broom or shovel handle and cut off a piece that is a comfortable length for your tool handle. Drill into one end of it to a depth of about 2 inches. The diameter of the hole should match the size of your copper wire (Something about 3/16" diameter is nice, but make all different sizes). Cut the wire so that when it is put in the hole it extends out about 1 1/2". Hammer the wire to a point at the end. I would also suggest that you hammer some flats into it as shown in the illustration. You may want to add a set screw to hold the copper tip in place.



**Copper Tip Pressure Flaker**

If you want you can make the handle a couple feet long and turn this into an Ishi stick. Many people feel they can get better leverage using the longer handle and bracing it under their arm or against their side.

---

From <http://www.onagocag.com/tools.html>, April 1 2010, Copied with permission

Note: Wyatt R. Knapp is the author of "The New Atlatl and Dart Workbook" to be released Summer 2010.

# Pictures of Modern Tools from Primitive Materials

By Charlie (aka Stonefacescar)

here are the tools that I made and use...

copper ishi stick, hammer for dressing tool tips.



split branch ishi stick



ishi stick adjustment



wrapped



another hammer, encased in rawhide



pressure tools





hand flaker, showing the little bent 'cleat' or 'spur' that locks the tool into the inside of the handle



percussors



raw copper nugget percussor, and a splitting wedge/percussor



antler tine holders



done with these tools



notching tool tip shape..



if you use branches off a tree, instead of dowels, it is easier to split the branch, down center, and it is easier to follow the 'pith' to hollow out the center with stone tools, for the antler or copper tools tips...

hope this helps

Charlie

---

From <http://www.paleoplanet.net/>, April 3, 2010

# Making a Horseshoe Nail Notcher

By Mark Dellinges

I made this horse shoe nail holder from plumbing supply parts. You'll need a 1/4" hose barb adapter, 1/4" brass pipe nipple, 1/4" pipe cap, horse shoe nails, wooden dowel, self cured acrylic resin or epoxy resin, and optional rubber tubing.



Fill the inside of a hose barb adapter about half way up with resin and insert a lubricated horse shoe nail. Allow to set and tap out the nail. Nails of similar type are now interchangeable and have good "side to side" stability.

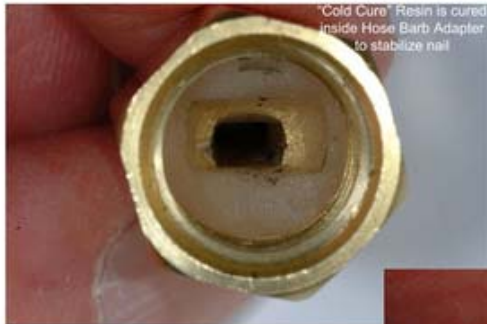

Now assemble by screwing the hose barb adapter to one end of the pipe, insert the wood dowel and tighten the pipe cap to the other end. Note the good "front to back" stability. If the nail should loosen while in use just tighten the pipe cap.



1. Put nail into tip and screw onto pipe.



2. Insert wood dowel into end of pipe.



3. Screw pipe cap onto end of pipe.  
*(tighten as required to prevent movement of the nail)*

My "narrow entry" notching really improved once I found a way to keep the horse shoe nail vary stable. I hope this helps!

---

From <http://paleoplanet69529.yuku.com/reply/275691#reply-275691>, April 4, 2010,  
copied with permission

# Making Boppers

by Jim Keffer (aka reefera4m)

For those of you that would like to make your own boppers, here are some photos and tips on how to get started. There are many way to make good boppers - this is just the way I do it.

1. Start by getting organized. Things you'll need, 1) anvils for doming the caps or a doming block/doming punches, 2) hammer(s), 3) clamps, 4) acetone and paper towels for clean-up, 5), a good 2-part epoxy with mixing containers/stirrers, 6) component parts - copper caps, hard lead, handle material, 6) steel wool/sandpaper.

Here is how I start out:



If you don't have a doming block/punch set or want to make larger boppers, there are a number of things you can use for anvils. I use hitch balls (one of which I've ground down by turning it in my drill press), steel round bar w/rounded ends, and ball peen hammer heads. You can also use carriage bolts.





The most important step is doming the cap. The rounder and more even the dome the better the finished bopper will be. I use various ball peen and auto body hammers to dome the caps. While hammering out the cap I also occasionally scrub the cap with steel wool. This serves to highlight any high/low spots on the cap due to hammering. I go back after each steel wool scrubbing and, using progressively smaller hammers and a lighter touch, continue to smooth out the cap:



Because I turn the handles on a wood lathe, I like to get a good even fit. I true the ends of the copper cap using a small block of granite and sand paper:



To insure the best bond of cap to handle I sandblast the interior of the cap. (A study by a couple of guys that make knives professionally found that sandblasting metal provides the best bond when using epoxy to bond metal to wood or antler). Roughing it up with sandpaper also works.



\$20 Siphon Sandblaster:



Now I fill the caps with hard lead (wheel weight lead or lead with additives). It is important to level the cap prior to pouring the lead to get the most even weight distribution and make the bopper perform more consistently:



No photos of the lead pouring - too hard to take photos and pour lead! I just fill the domed portion of the cap. If the lead does not settle evenly, I re-heat and make sure it is even.:



Once the lead cools and the cap size is stable, I turn the handles. Boppers can be made with dowels, whittled wood, plastic rod, etc. I just happened to have a wood lathe and make handles that fit the hand and reduce slipping. I use a variety of wood types and each has different characteristics. Oak and Walnut look very nice and are very durable woods. Some knappers on the other hand, prefer maple which is lighter and allows for more weight distribution towards the tip. Mostly it is a matter of what's readily available or personal preference.



After 4 handles, the last one!



The caps are dry fit to the handle. They shouldn't be too snug or there won't be enough area for the epoxy:



Next I mix a good two-part epoxy (Loctite Heavy Duty Professional - available at most hardware stores). Since I make a lot of larger boppers (1", 1 1/4", 1 1/2" and 2"), I epoxy the lead in the cap and then the cap to the handle and clamp. I also pin the caps on the 2" boppers with copper rivets - epoxy alone is not enough. You can 'punch' the lead in smaller caps for a snug fit if the lead is soft enough. It is more difficult if you use harder lead. Getting lead to adhere to the copper like solder also doesn't work as well if you add zinc or antimony to the lead (makes the lead harder). Epoxy works great and harder lead deforms much less than soft lead so I still epoxy the lead in the cap. In over 200 boppers I've never had the lead come loose (I have had the copper wear through to the lead). Clamp securely and remove any excess epoxy with paper towels and acetone:



Pinned 2" cap



Once the epoxy sets, I do some final sanding of the handles and apply some protective wood finish. This is not merely for looks - a good finish, like Birchwood-Casey's Tru-Oil, seals the wood and prevents it from shrinking/swelling with changes in humidity. I think that drying/shrinking wood is one of the main causes for caps coming loose. In the two or three boppers I've made where the caps have come loose (but not off), I believe that shrinking wood was the culprit. Making sure the handle wood is thoroughly dry and sealing it well helps prevent the wood from absorbing moisture and the swelling/shrinking cycle. Another good choice is MinWax Wood Hardener - it both seals and hardens the wood. It also helps to have a stand for the boppers to dry.



Here's what you can end up with:



---

### **P.S. Giving away my secrets**

I've shared my method for making boppers with a number of people but I thought I'd make it universal. I've experimented with making boppers quite a bit over the last year and can honestly say these "Secret tips" work.

'Secrets' in **BOLD**

**Plan on one hour labor per bopper.**

Standard copper cap but **Nibco** brand seems to be the best

**Hardened Lead** - wheel weights work good but adding extra **zinc** works better at preventing the cap from deforming.

**Fill just the 'domed' part of the cap - no more - just the domed part.** Best placement/distribution for the weight and leaves plenty of surface area for the epoxy.

**Hand-hammer** copper caps on rounded steel anvil - work hardens much more than a doming punch.

**Bed cap in moist, cool sand and LEVEL** prior to pouring lead. The sand wicks away the heat preventing or reducing annealing, the leveling insures the best balance of the lead weight in the cap. Alternative - quench immediately after pouring lead - **USE CAUTION** - this will not harden copper like it would steel but does seem to prevent the softening, thus retaining most of the work hardening. The lead will usually be loose after it cools so plan on using epoxy to secure the lead to the inside of the cap.

**Sandblast the interior of the cap** prior to attaching with epoxy. Sandblasting is the **BEST** way to insure a strong glue-up.

Where the cap slides over the handle make sure the fit is snug but **leave just enough room for the epoxy**.

**Glue the lead to the cap first** - sometimes if you 'tin' the inside of the copper cap the lead will adhere but this is the exception as copper cools faster than the lead. I epoxy the inside of the cap under the lead, add the lead back, coat the inside of the cap and the outside of the handle where the cap will fit and clamp snugly until the epoxy sets.

Use **Loctite 'Professional Heavy Duty'** 2000 psi epoxy. (available at Lowes or Home Depot). Stronger epoxy like Loctite Hysol E20HP (4,000 - 6,000 psi) is too strong and you won't be able to replace the cap. When the copper wears through to the lead, simply heat the cap and pull off. Form a new cap and melt the lead from the original into the new one and re-attach with epoxy. A standard propane torch can accomplish this in about a minute or two.

Handle size is a matter of personal preference but the vast majority of requests I get are for handles between 4" - 5 1/2" (80%) 15% are shorter and only 5% are longer. **BUT you can always shorten a long handle!**

Finishes are a matter of personal preference - and my preference is Birchwood-Casey Tru-Oil - used to finish gunstocks. Just don't finish too smooth (220 grit is good) or the handle will be too slick to hold.

---

from: <http://paleoplanet69529.yuku.com/topic/36877> and [/topic/34690](http://paleoplanet69529.yuku.com/topic/34690), accessed 12-5-10, copied with permission



## Something New to Me – Notching Jig

By Richard Myers ( aka Twobears)

I found out about this totally by accident. I was notching an Andice this morning when I blew the ear off and stuck my notcher in a crack on my work surface. A light bulb went off and this is the result.





Any way it works great and was able to get the next notch in good and deep as seen in the picture. Has any one else used something similar? This really does a fine job and it thins it's path well too. I leave the shank in place and push the point against it and then tap with my bopper and pow it removes a great C flake. It's a lot more stable than trying to hold the notcher and you can get a more exact positioning.

---

From <http://paleoplanet69529.yuku.com/topic/37981/t/Something-new-to-me-notching-jig.html>, accessed 9/16/10

## Simple Fluting Jig Pictures

By Ken Wallace (aka Paleoman 52)

To go along with the thread on fluting nipples I am posting a few pics of the fluting jig I have been using since 1993. As you can see this is a pretty uncomplicated device. The secret to making this jig work well is to be sure to spend as much time as you need to on preparing the fluting nipple. Always make sure that the ears of the point aren't pressing too hard against the uprights because this will cause them to snap off. Also be sure that when you are applying maximum pressure that the bar is almost 90 degrees with the preform. It helps to give a tug on the bar once you've applied the pressure you need to cause the fracture that releases the flake.





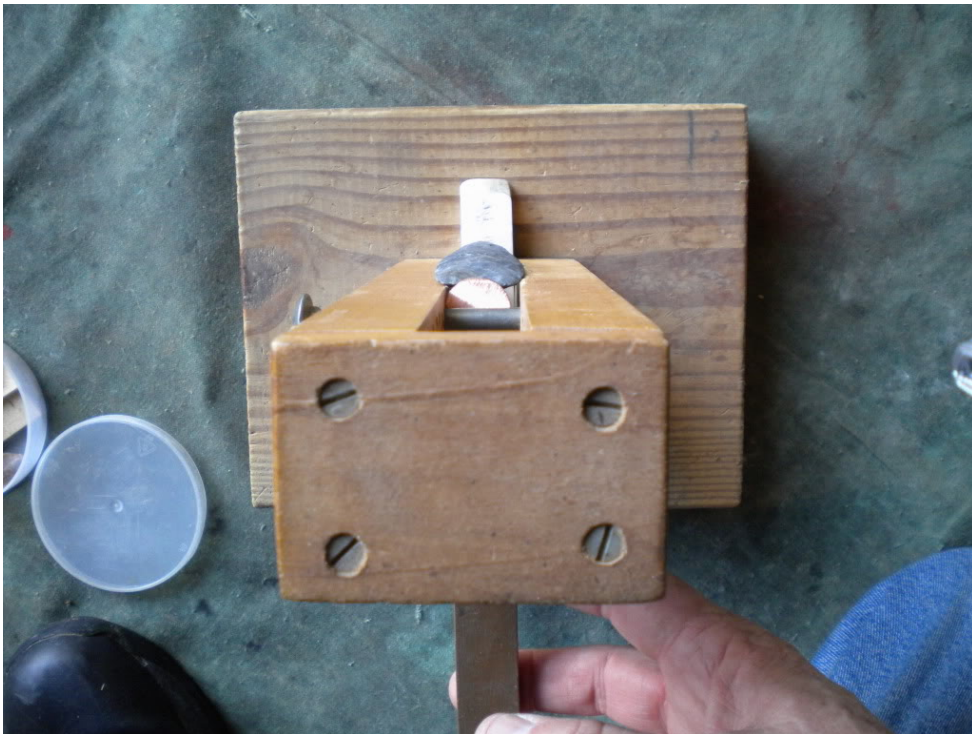

---

From <http://paleoplanet69529.yuku.com/reply/294764#reply-294764>, April 4, 2010, copied with permission

# Tony Soars Fluting Jig

Posted by Richard Meyers (aka Twobear)

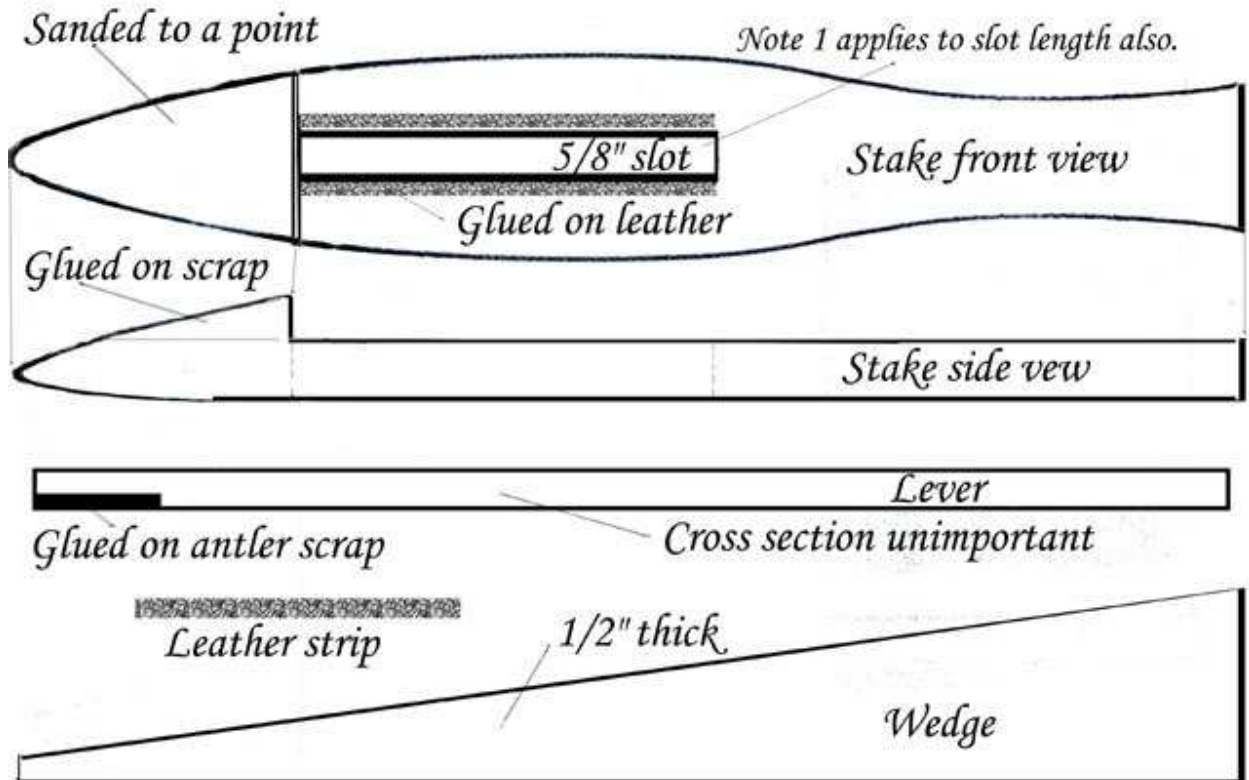

## The Soars Fluting Jig Construction details

- Notes: 1. Lengths of boards to accommodate length of points to be fluted.  
2. Construct of 1/2" hardwood.

From <http://paleoplanet69529.yuku.com/reply/294764#reply-294764>, April 4, 2010, copied with permission

## Rocker Punch Board

By Gary Abbatte (aka rhymeswithwhat)

I have interpreted the research of Dothager to construct a modern set of tools using similar physics and a blending the two Dothager tools into one practical set. The key to his Three Digging Stick Tool is the slot or space between the sticks and the use of a foot lever stick and thong to pull down a larger punch and hold it while striking. His second tool, a small split out branch tool, uses a tied down small punch. Both tools use leather pads or a pad over an anvil stone as an aid to locate the height of a preform or spall and set a striking angle for the punch and billet. Here is my tool set that combines the both lap tools into one with modern materials:



At the top is a large Cow Bone punch and a large Antler punch with a leather pull thong around it . The thong connects to the foot operated pedal stick for holding the punches firmly against the workpiece. The pedal stick and thong also holds the lap board very steady across the top of my legs when seated in working position and applying pedal pressure. The lapboard itself is oak, covered with leather and the other end away from the slot on the board is used for small punches that are tied down using a clove hitched leather strip. The underside of the board that rests on my legs is also covered with leather for comfort. The tools at the left are my striking tools: A Dogwood Billet, A Moose Tine Billet and a Limestone Billet. Small Antler punches can be seen at the right end of the board and one is fastened down in working position.

Below the Foot lever stick is a variety of leather pads and an anvil stone.



A closer picture of the slotted punch board end.





Billets, anvil and padding.



Small punches at the right end of the board.

Conclusion: This tool set has a lot of potential and I hope to gain skill using it. It is nice and steady on the lap and I can take large thinning flakes and shape preforms out of Onondaga with the set. If you are unfamiliar with rocker punch methods for Flint Knapping take a look at the Dothager video set and see how he uses his tools developed from his research:

[http://www.spiritinthewind.com/mike\\_1.htm](http://www.spiritinthewind.com/mike_1.htm)

Punch em out!

[To see this tool in use, go to  
<http://s30.photobucket.co...amp;current=punchvid.flv>]

---

From <http://paleoplanet69529.yuku.com/topic/29696?page=1>, April 4, 2010,  
copied with permission

# Knapping Aids for the Strength or Dexterity Challenged

Compiled and edited by James C. Keffer

This chapter takes a look at various knapping tools used by knappers to either help with specific knapping challenges or to overcome physical limitations. I've compiled a number of these tools and basic instructions on how to use them. To my knowledge, all of the tools were made and used by knappers, and permission to include these jigs, photographs and instructions has been granted by their originators.

## **Betty Roberts' Jig**

This jig was designed and built by Betty Roberts, of Oroville, WA. While better known for her amazing Spinning Wheels, Betty is an accomplished knapper and woodworker.

The jig is built with a wood base upon which a wood ramp is attached. A 'Drill Press Locking Clamp' (available at Harbor Freight (\$9)) is attached to the base with its own mounting bolt. The end of the clamp is modified so that a two-part pad, steel and plastic or rubber is attached. A rubber pad (notched or un-notched) is placed between the wood ramp and the clamp. The rock is held between the locking clamp and the wood ramp by the spring pressure (adjustable) of the clamp.

The jig uses two different fulcrums or 'cheaters' as Betty calls them.

Note – this jig requires a longer pressure flaker tip than is common on most pressure flakers. A pressure flaker that provides for an adjustable tip (set screw) is recommended.

The first is a nylon cord that runs across the end of the rig. This cord acts as a pivot bar for the tip of the pressure flaker and allows for a wider space to work the rock. The pressure flaker tip is placed under the cord and the tip placed on the rock. Lifting up against the cord causes the tip to be pressed down and into the rock to remove the flakes.



The second 'cheater' is a small, rectangular piece of plastic attached to the end of the jig with a screw. A hole is drilled into the top of the plastic to allow for the tip of the pressure flaker to pivot it. This 'cheater' provides for the most pressure in a small area.



Here's a picture of the 'Drill Press Locking Clamp' that is the key element of this jig.



### **Otis Price Jig**

This simple jig was built by Otis Price of Albuquerque, New Mexico. It employs a block of wood (2x4 or 2x6), a couple of leather pads (rubber may also be used) and several strands of stout wire. Notching the top leather pads provides a place for the flakes to release into. The wire strands provide the pivot for the pressure flaker. Its small size makes it easily portable. This jig also requires a longer tip on the pressure flaker.





### **Tim Monson's Lap Table and Knapping Aid**

Tim Monson, of Lehi, Utah has designed both a handy table and knapping jig all in one! This tool starts out as a lap size board onto which Tim attaches four storage hangers (also known as ladder wall hooks – about \$2.50 at most hardware stores). These hooks fit on the outside of the knappers legs while the board (lap table) lies across the lap.

On the working surface, the table has a jig employing two fixed blocks of wood, an 'eye' bolt (or bolts) that provide the pivot points for the pressure flaker or Ishi stick, and a flaking block. The flaking block is not attached but moves along the two small blocks to properly position the rock in relation to the pressure flaker.

Bottom



Top



Tim's made several variation of this tool, here's one with the double 'eye' hooks and some strips of wood attached to the side to keep tools from sliding off:



### **Jerry Marcantel's Jig**

Like Otis, Jerry Marcantel, of Tucson, AZ, has opted for efficiency and portability. Rather than using wire strands, Jerry's jig employs an 'eye' bolt (or bolts) to use as the pivot of fulcrum for the pressure flaker/Ishi stick.





---

from: e-mailed document; elements of this document can be found at  
<http://www.pugetsoundknappers.com>, copied with permission



# Converting a Pottery Kiln to Heat Treat Flint

by Mark Bracken

## Read this **DISCLAIMER** Before you Proceed

**Any person(s) using informations from this website constitutes acceptance of this agreement.**

Advanced electrical knowledge is **REQUIRED** to begin and or complete this kiln modification

Person(s) using this information or any information offered by this web site are fully responsible for the transfer of this said disclaimer to any other persons user(s) of any informations offered by this web site.

The user(s) assumes full responsibility for the proper interpretations and safe use of these information(s).

Informations here are **Not** recommended for children under 18 years of age.

Keep products and all related products away and out of reach from pets and children.

Improper installation, care or use of products could result in property damage, Fire, electrocution, blindness, serious injury or death.

Safety goggles are **required** during this procedure. Avoid inhaling fumes or dust. Must use proceed with proper ventilation. Must dress properly, wear shoes that completely cover the foot, Full length pants and a shirt are required during installations or modifications.

Must wear heavy leather gloves accompanied.

Consult your physician before you proceed if you suffer from any Breathing illnesses, bleeding disorders, tendentious, carpotunnel or any other discomfort before proceeding.

If problems and or discomfort result, discontinue use and consult your physician.

Do not consume alcohol, drugs or other mind altering substances during this procedure.

If any product defects or excessive product wear are discovered, **do not** attempt to use.

In no event shall the manufacturer(s) or retailer(s) of products used or sold on this web site be liable for incidental or consequential damages or for any other damages to the properties or person(s) of the buyer and or user. The recovery for damages resulting from any and all causes whatsoever, including, but not limited to, misuse, negligence, or strict product liability, will be exclusively limited to the replacement of the product(s) with respect to which losses or damages are claimed or to a refund of any purchase price paid for the products. If you wish to or have purchased products or used information(s) from this web site and **DO NOT** agree and or accept this disclaimer, **DO NOT PROCEED**. Proceed and or use at your own risk.

## Switch Installation

Proceed at your own risk. This switch, Robertshaw 5500-135 commercial infinite switch, is designed for 120v. It can be purchased from any appliance parts store. I recommend the commercial grade switches. Each switch is to be used with one element ranging from 13ohms to 18 ohms. If your kiln holds one 5 Gallon bucket of rock then one switch will be enough. I have a kiln that holds 18 gallons of rock and I have three switches on it. The temps should not be allowed to exceed 800f. NEVER use the kiln on or near the "high" setting. Use caution when settings are near the "high" setting, the kiln could lock in "high" mode and will cause damage to your stone and possibly element(s). Never operate your kiln near any flammable vapors including, Glues, solvents, fuels or others . Infinite switches produce small sparks as they "toggle" in their operation. The switches have a dial with numbers from 1 to 6 on them with quarter and half marks on them. The dial settings are NOT temperature settings. For example: You must experiment with your kiln to find out what temperature #4 produces. It might be 375f. Make a chart and write down the final values of each setting. Be sure that you are allowing at least 24-36 hours for your kiln to max out at the dial setting you have selected. Don't become tempted to monkey with the dial when your trying to establish final values for a dial setting. Always fire FULL loads of material.

### Read this carefully!!!

If you are unfamiliar with proper and safe installation DO NOT PROCEED

1. Unplug all power before working on your kiln!
2. Mount your switch in a metal box on the side of your kiln. Mount with good and safe clearance from any electrical connections to the element or switch itself.
3. Be sure switch is mounted with the "top" indicator is facing upwards. See diagram below.
4. Use a 14 or 12 gauge cord with ground wire. The best option is to make up a new one or remove one from an old appliance with a ground wire still intact. Washing machine, refrigerator, microwave ect... are suitable.
5. Wire switch as shown in the diagrams below using quality crimp connectors. NO ELECTRICAL tape.
6. Check all connections with a multi-meter to insure there are no "shorts" or "longs".
7. Double check your element to be sure it is in the Ohms operating specifications of this switch as per diagram. Do Not Use old or original elements with this switch. They are not compatible.
8. See diagram Below for details. Please note: the "P" connector is not used on this configuration!
9. Use proper terminal leads on all connections, NEVER use electrical tape! NO connections should be located inside the kiln. All connections should be clear of any metal or conducting parts!

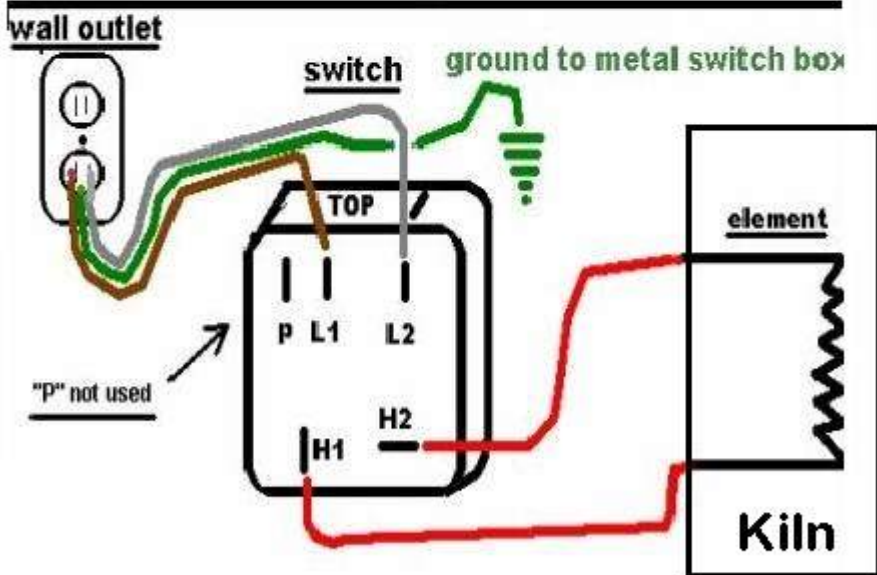
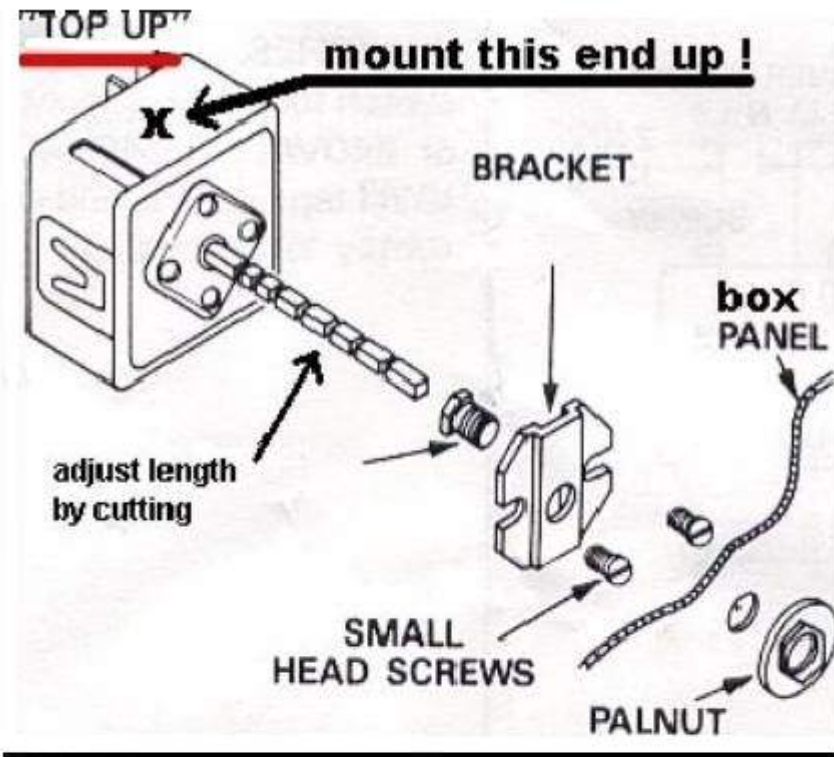

Brown = common  
 gray = Hot  
 green = ground

**Operate the kiln safely!**

1. Never operate kiln on a wooden or flammable or combustible surface.
2. Place kiln elevated on concrete blocks or metal stand. Do NOT set directly on any floor concrete or otherwise!
3. Keep kiln at least 20" from any walls or other objects at all times.
4. Use cement fiberboard on near by walls for an extra-added protection!
5. Use a "dedicated" outlet for each kiln switch on a 15-amp breaker.
6. Never heat-treat large blocks of stone. Stones could violently break apart. This could knock the lid right off a kiln ejecting VERY hot Fragments, creating a serious fire hazard!
7. Keep your kiln out of the weather, Damage to electrical parts will result.
7. Never operate kiln with flammable fumes, liquids, solids or vapors present.
8. Avoid heat-treating in your home or living space. Heating rocks can produce poisonous or harmful vapors, especially if cut on rock saw!
9. ALWAYS WEAR A RESPIRATOR WHEN LOADING OR UNLOADING YOUR KILN!!! DUST FROM BRICKS AND ROCKS ARE DANGEROUS TO YOUR LUNGS!

---

From [http://www.flintknappingtools.com/heattreating\\_kiln.html](http://www.flintknappingtools.com/heattreating_kiln.html), March 31, 2010,  
copied with permission

## Dan's Cave

© Long, Dan (2001). CHIPS: The Flintknapper's Publication. Vol. 13,  
#2 April. (unauthorized reproduction prohibited.)

Every man needs a place where he can go to "get away from it all" once in awhile, a cave to hide away in; a place for male bonding, making silica dust and washing it down. Whether it's a room in the basement, or, if a guy's lucky enough, a workshop out behind the house. A place, other than the local pub, where your wife will know where to find you.....yet leave you alone to "create", knowing that you really can't get into any serious trouble "out there". This is the story of my "cave" and how it came to be.

I started knapping almost ten years ago now. Back then it was an outside only activity, done on occasion with a hammerstone and some chunks of Onondaga I picked up walking local fields.....oh yeah, and band-aids too of course. I was curious and interested, but the obsession hadn't quite kicked in yet. After some initial struggles (who didn't?) I found a copy of D.C.'s "The Art of Flintknapping" at the Buffalo Museum of Science. I was astounded.....I couldn't believe that such a thing existed. Boy, I thought, I've got it made now! After reading and struggling some more, I came to the conclusion that I just had to have somebody show me how to do this. At about this time I was introduced to Jack Holland, a gentleman well known in both knapping and archaeology circles....."Mr. Lithics". I pretty much just tormented Jack until he was kind enough to invite me to his home to give me a knapping lesson.....I guess it was either that or learn how to deal with a stalker! Jack showed me the basics, saw that I was sincere in my desire to learn, and decided that he should get me on down to meet Ken Wallace, a knapping legend here in the Northeast.

To make a long story, well, a little shorter. Ken and I became fast friends and I was put firmly on the road to learning this "lost art". Having a good teacher accelerated my abilities light years beyond where I would have been had I continued to struggle on my own. I still consider myself extremely fortunate to have met such a skilled knapper, and one who so easily and generously gave of his knowledge, so early in my knapping career.

The first time I visited Ken with Jack, as I sat in his home marvelling at the case after case of work that he put before me, I wondered where all of this magic happened. My question was answered as we moved outside to "the shop". Ken's shop was small, with a low, sloped ceiling and a wooden floor.....I could see small pieces of debitage imbedded in it and caught between the boards. There were things to see in every nook; arrows, darts, antlers, tanned hides, trade beads.....I was overwhelmed!! The day was somewhat of a blur; it would have seemed almost dreamlike looking back at it later that night, had it not been for the paper thin Snyders point that I clutched in my hand....one of Ken's signature pieces and a gift to remember the day by.

Needless to say, I returned home totally pumped up and ready to knap. I looked at my little room in the basement, the one I shared with the boiler. Sure, it was plenty warm, but the light

was poor and ventilation was non-existent (we tend not to open our windows much in Canada in the winter). Of course there was the rickety old garage, which was fine if it wasn't really cold....kept me out of the wind anyway. I didn't have to worry too much about the flakes on the floor either; we didn't put cars in the garage and it had a gravel floor, as the previous owners had removed the old wooden floor after repeated skunk infestations under it. This wasn't the most pleasant place to knap.....I needed a change.

My next attempt at a knapping studio brought me to our cottage, which is on a large river a short distance from the house. I got hold of a huge canvas tarp at a flea market, moved all of the furniture aside and covered the floor with it. This worked fairly well until Spring, when even after repeated vacuuming of the carpeted floor, my wife, who lives in bare feet as soon as it's warm enough to do so, started to "discover" small hidden flakes. Looked like I needed another plan.

It was time to tear the garage down before it fell down and build a new structure; not a garage but a combination workshop/storeroom. I attacked the garage, and to say that it was in trouble is an understatement; I took the whole thing down with no more than a crowbar....there was nothing bigger than a 2x3 in it!

I had designed an L-shaped building with the larger part of the L being the shop and the shorter part the storage area. After visiting the City planning department I found that I could build a much larger structure than I had thought, but I fought the temptation to eat up too much of the backyard (my wife loves her gardens), so I settled on a 16'x20' area for the shop and a 10'x16' area for storage. I knew that these nice even measurements would make construction easier too. I set to excavating for the floating concrete pad that the whole thing would sit on. Things got interesting almost immediately as I found a few flakes of aboriginal debitage in the soil just outside of what would have been the garage, so I know that it wasn't mine. It really wasn't a total surprise as we live less than two blocks from the Niagara River in one direction and about two blocks from a large tributary of it in another. I considered this an incredibly good omen, even more so than if I had found a point; knowing that prehistoric people had knapped right on that spot made it seem perfect. I even incorporated some of the flakes and a couple of my points into the concrete as we poured the pad.

The structure went up fairly quickly, thanks to pre-fab trusses and a friend who just happens to be a carpenter! We included two large windows on opposite walls on either side of the knapping area, and in line with the prevailing wind for flow-through ventilation. I wasn't just building a workshop for all of the things it might be used for.....I was building this thing with knapping as the primary consideration. I'd already decided where I would be sitting to knap; looking at the window that faces the house so I could see and hear my wife when she called me in for a meal. Being in the throws of a heavy knapping session is one of the few things that will cause me to forget to eat!! I've since installed an intercom to take care of these things in the winter months.

In addition to the two large windows for ventilation and light, I installed a 2'x4' skylight directly over the knapping area. If there is one piece of advice I would pass on to anyone considering building or modifying a shop for knapping, it would be to put in a skylight; it makes all the difference in the world.

It was finally time to begin finishing the inside of the shop; wiring, insulation, deciding where the workbench and power tools would reside, and in which corner the kiln would sit. Figuring out all of this ahead of time also helped me to distribute my electrical load evenly throughout.

Now, what to cover the walls with. I had decided to keep the ceiling open to keep the rafters available for storage (glad I did), but I did want to cover the insulation in the walls with something. I didn't really want to mess around with drywall....had to keep reminding myself that this is "just a shop". I looked around for an alternative and came up with a solution.....at work! I'm a lineman for an electrical utility, and our yard at work had a quantity of hydro poles that had outlived their usefulness. They are western red cedar from British Columbia, and some of the guys had started milling them up and making decks out of them, so I thought, "Why not panelling?" I had them milled to 3/4" thick and whatever width each pole provided. Once through a thickness planer to achieve uniform thickness and smooth them out (and bring out the grain beautifully), and they were ready to go up on the wall. They looked, and smelled, great!

The only wall I didn't cover with the planks is the one behind the woodstove, which is a wall of 100 year old bricks I picked up on my travels. Cedar is a fairly soft wood, which was evident after my "shop warming knap-in" when I found small chert flakes actually imbedded in the walls!

I next hung two eight foot, double tube fluorescent lights on either side of the knapping area and a ceiling fan directly overhead (more air movement). Feeling that I'd covered just about everything; heat, light, ventilation, communication, storage, even a small beer fridge (gotta wash that silica dust down somehow), I realized that the only thing lacking was a bathroom. I hadn't run plumbing to the shop, and knowing that I had neighbours all around I couldn't use the method that we used at Ken's shop (out the back door). Not wanting to leave a toasty warm shop in January to run to the house, I had to come up with an alternative; so I dug a three foot deep hole outside, drilled a hole through the wall and ran some PVC tubing through it. The end of the tubing was at the bottom of the hole in the ground, which I proceeded to fill with alternating layers of sand, gravel and activated charcoal (for odour control). On the inside end of the tubing is a large funnel (the kind you use for draining your motor oil), and behind that on the wall is a small piece of plexiglass.....a splashguard for those knappers who have trouble "hitting the platform". The first test run gurgled back at me....I hadn't considered the requirement of a drain vent. A small hole drilled into the PVC just before it disappeared under the ground solved that problem, and a "flush" from a jug of vinegar keeps things clean without pouring chemicals into the ground. The "bathroom" is even strategically located in a corner so that the user can be behind the door of the shop for a little privacy.

Adorning the walls are several cases of points that I've traded for or been given over the years, and several posters; The Story in Stone poster of course, Pete Bostrom's Clovis poster, and Val's drawings of the Wenatchee points among others. I even have an award that I was presented with at a knap-in a couple of years ago in Pennsylvania.....it was for being "The First to Arrive".....OK, so I got the dates wrong and went a week early!

Are there any things I'd change in retrospect? Yes, only two: First, I didn't know about "cold start" ballasts for fluorescent lights. Seems the lights I hung (the price was right) are made for indoor use only; the air has to be at least 50 degrees for them to operate properly. This is remedied by getting a good fire going in the stove before I settle in to knap.....not a big deal. Secondly, I put a "brushed" finish on the concrete floor, which I thought nothing of until the first time I tried to sweep up flakes.....should've left it smooth. Again, this is taken care of by using a tarp to knap over, which makes clean up easier anyway. All in all I've been very happy with the result, and the knappers that have joined me over the last couple of years have given the place a hearty thumbs up!

If you're considering moving out of the basement or garage, or even modifying an existing space to be more knapper friendly, I hope that some of the suggestions I've put forth here will be of some use to you.

Oh yeah, and don't forget the vinegar!!

---

From [http://knapper\\_dan.tripod.com/page2.html](http://knapper_dan.tripod.com/page2.html), April 4, 2010, copied with permission



*Pictures of Dan's cave from <http://www.creeksideartifacts.com/DLKI/index.html>*



# Paleoman52's Man Cave

by Ken Wallace (aka Paleoman52)

When I started this thread last week I forgot to include my outside cave. Here are a few shots of where the magic takes place. Many of you have been here and will recognize it very well, for those of you that have not been here yet, I welcome you to stop by, My cave is always open to you. My only requirement is bring a rock with you, enjoy!



This is the outside of my Cave and it kinda looks like a cave with that big opening and all the different antlers hanging around the front.



This is the area I like to sit during warmer weather and chip out my creations. It has a good view of the neighborhood and sometimes my neighbors spot me here and bring beer to share.



This is in the inner cave where I collect my finished pieces and grab cold ones out of the fridge to celebrate the successful completion of any point that doesn't break.



More views of the inner sanctum of my cave, this is organized but my wife considers it very messy, Hey I know where everything is, that all that counts.



This is my meager rock supply that I have, when this gone I don't chip anymore until someone brings rock to the area, or I travel to a local knapping gathering.



OK this picture kind of speaks for itself. Am I the only one brave enough to show "The Funnel"? This is one of the most popular places in my Cave and is visited at least one or 2 times a day by everyone when we gather for a day of chipping. I'm sure that all caves have different forms of this feature and recently I have rebuilt and improved my "Funnel" to handle more volume when my friend Mike arrives at my place after he drives in from Niagara Falls, NY. If you look closely you can see that there is a

handle hanging from the rafter to pull if the need arises and also a miniature toilet on the shelf next to the "Funnel" that has a handle to trip and it is complete with full flushing sounds.

It may not be a place of beauty but it is my Cave and I enjoy every moment I spend out there, I hope you enjoyed your tour!

---

From <http://paleoplanet69529.yuku.com/reply/261940#reply-261940>, April 4, 2010, copied with permission

## Exhaust Fan Setup

By Mark Green (aka clamdigger)

In another thread we were talking about silicosis, and breathing in dust and fumes from grinding rock and glass. I've been knapping indoors for about 20 years and I believe it has damaged my lungs. I developed asthma in my thirties and had a terrible bout with pneumonia which knocked me down for nearly 8 months. I'm not blaming the knapping entirely but I feel it has made a contribution to my over all poor, pulmonary health over the past ten years.

I've had to give up my Harleys due to the fact that every time I'd go out for a rip, I'd come home barely able to breathe. There was no way I was gonna give up knapping as well. So I installed a powerful in line exhaust fan adjacent to my knapping chair. I use this fan every time I go to knap, and I've noticed a significant improvement in my breathing and over all health. I used to contract many sinus infections prior to the use of the fan, in the past 2 years I've had maybe 2 infections.

For those of you knapping indoors, you may not feel it now and you may never have a problem, but this stuff builds up over a long period of time. Out of nowhere you start to feel like shit. It's taken me about 3 years now of really being careful with the dust, my chest and breathing are finally starting to feel good.

Here is my set up





The intake and exhaust are 6" diam. a flexible duct can be installed on the intake and you can route the duct where you need it, although I wouldn't make it too long. This set up cost me around \$225

---

From: <http://paleoplanet69529.yuku.com/topic/38560/t/Exhaust-fan-setup.html>, accessed 10-11-10, copied with permission



## **Section 3: Percussion**

# Platform Preparation Variables in Bifacial Reduction of Flaked Stone Tools

## Tools

by Errett Callahan

### a. SHARPNESS OF EDGE



#### TOO SHARP

Edge may collapse or release small flake. Dull by abrading perpendicular and/or parallel to lineal edge with coarse abrading stone.



#### CORRECT

Dull only enough to prevent collapse of platform. Correctly dulled, without releasing flake should release with first strike.



#### TOO DULL

Excessive resistance, causing billet to glance off without releasing flake. Reflake so as to reduce thickness of edge.

### b. ANGLE OF BEVEL



#### TOO LOW

Edge may collapse. Rebevel to steeper angle.



#### CORRECT

Bevel to 60°-70° so edge points slightly downward and flake releases on first attempt.



#### TOO STEEP

Force may glance off. Rebevel to lower angle. Avoid continued striking.

c. PLACEMENT OF PLATFORM



ABOVE CENTER

Flake may be short or biface may break. A major cause of fracture. Lower platform.

CENTERED

Flake may travel to center. Less chance of fracture. Ideal for primary thinning.

BELOW CENTER

Flake may span width of biface. Minimum chance of fracture. Ideal for secondary thinning.

d. PLATFORM ISOLATION



EXCESSIVE ISOLATION  
May produce narrow flake of little mass.  
Reduce isolation.

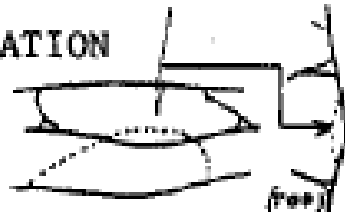

SLIGHT ISOLATION  
May produce massive flake of predictable attributes.



NO ISOLATION  
May expand to wider than long and terminate in hinge fracture.  
Increase isolation.

e. CURVATURE OF SURFACE

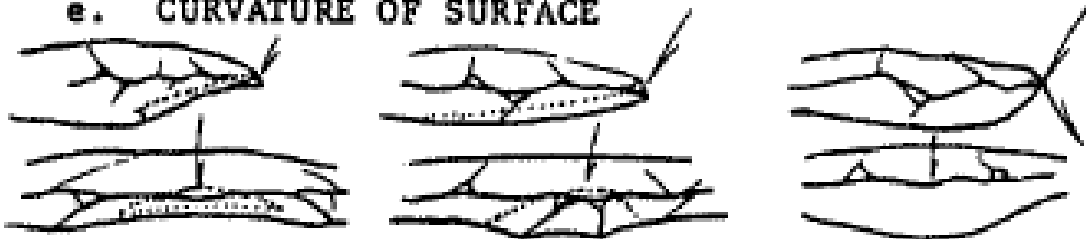

**CONCAVE TO FLAT**  
Force may dissipate and flake may step or hinge upon encountering greater mass. Round off overhang.

**SLIGHTLY CONVEX**  
Allows for optimum removal of mass with least resistance.

**OVERLY CONVEX**  
Excessive resistance, preventing flake removal. Lower platform or remove hump from another direction.

f. STRIKING ANGLE



**TOO STEEP**  
May release short flake or glance off platform. Lower striking angle. However, ideal for trim between major flake removals

**CORRECT**  
Strike at 130° to expected flake scar for optimum results. Alternately, strike perpendicular to center plane (but not to platform).

**TOO STRAIGHT IN**  
May split biface with overshoot or deeply hinged flake or may produce partial cone and crushed edge. A major cause of rejection. Raise striking angle.



g. ACCURACY OF AIM



TOO LOW

May either fail to release flake, crumble platform, or yield flake smaller than desired. Aim higher.

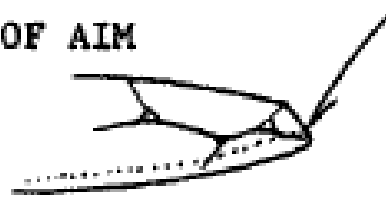

CORRECT

Ideal contact point is about 1/8" back from edge. Correct platform attributes help assure correct release despite slight inaccuracy of aim.



TOO HIGH

May either fail to release flake, or break biface in two. A common cause of fracture. Aim lower.

h. SQUARED EDGES



REMOVE "BLADE"  
Strike so as to remove an elongated flake down one or more corners.

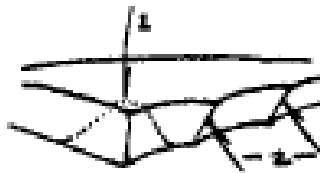

UNIFACIAL BEVEL  
Or bevel by striking a series of flakes perpendicular to edge, flip over, then strike perpendicularly at center of ridge.



BIFACIAL BEVEL  
Or work alternately from face to face, maintaining a centered edge.

## 1. THINNESS OF EDGE

On excessively sharp and thin edges such as flakes or blades, remove excessive thinness so as to create a beveled platform capable of withstanding collapse.



## 1. LIP FORMATION POSSIBILITIES



	1	2	3	4	5
LIP	-	✓	-	✓	✓
GULL	✓	✓	-	-	-

All forms are possible with all load types but ratios of occurrence vary.

Lips tend to occur more often when crack split is delayed as with softer percussors.

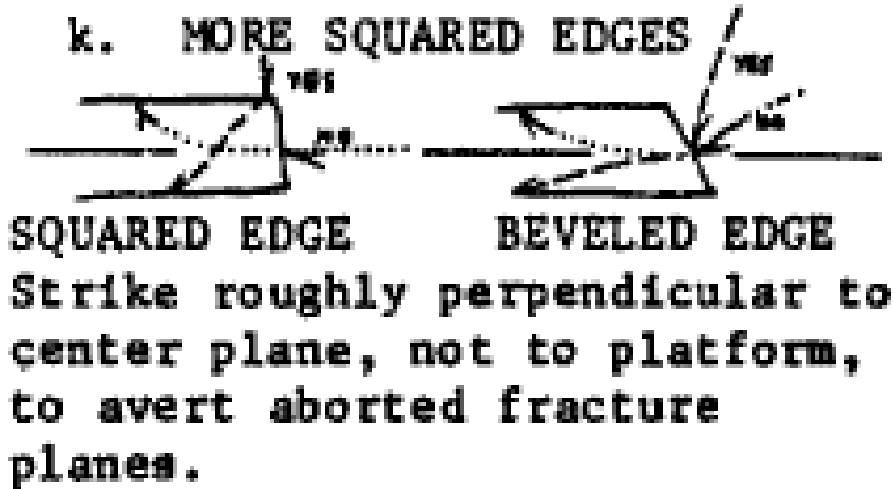

---

From: Table 11 in Errett Callahan's (1979). *The Basics of Biface Knapping in the Eastern Fluted Point Tradition: A Manual for Flintknappers and Lithic Analysts*. *Archeology of Eastern North America*, 7 (1), 1- 180. [A CD containing this paper is available online for \$45.00 at <http://www.esaf-archeology.org/publications.html>.]

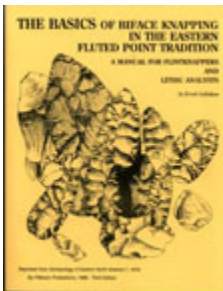

A revised and updated 4<sup>th</sup> edition of *The Basics of Biface Knapping in the Eastern Fluted Point Tradition: A Manual for Flintknappers and Lithic Analysts* was published in 2000 by Piltdown Productions, 2 Fredonia Ave., Lynchburg, VA 24503. [The "Basics..." is out of print for now. However, see more publications from Piltdown Productions at <http://www.errettcallahan.com/piltdown.htm> .]

Copied with permission from Errett Callahan.

# Percussion Flint Knapping Tutorial

By Tom Sterling

Here's the actual theory put into action. Doc Higgins is holding a piece of "Silver Sheen" obsidian (named because of the gray layers in it) that he's going to turn into a seven inch blade. This is a large, angular and knobby piece of obsidian, a naturally occurring volcanic glass. Native Americans favored this material for stone tools, using it whenever they could obtain it.



Note the heavy leather glove on his left hand, and the thick leather pad on his leg. The flakes he'll be removing are said to be the sharpest edge known to man. Because of the conchoidal breakage characteristics of obsidian, the edge produced is feathered out to an edge one molecule thick, far sharper than the best surgical steel.

Here Doc's about to take the first in a long series of flakes from the obsidian. He's using a solid copper bopper here, and will be hitting about one third of the way up from the bottom of the edge nearest the bopper. The flake will detach from the underside of the stone. By controlling where he hits the stone, the angle he holds it, the angle he strikes it at, and the force of the blow he will gradually remove unwanted portions, resulting in a beautifully flaked blade with matching flake scars. He's been doing this since about 1990, and is self taught. I've



(Tom) been doing this for about two years, and can produce blades only half the size Doc can, and not nearly as pretty. I also break quite a few. For me, a tragic case of theory wildly outstripping performance.

While anyone can learn to knap successfully, truly beautiful work requires lots of practice and extreme dedication.

Here Doc has struck off the first large flake and is holding it in the position it came from. You can see the edges as dark black lines. After studying the rock carefully, he has chosen this particular corner because of the ridge you see running under his thumb. Flakes tend to follow ridges quite well, and a skilled knapper can direct which direction a flake will run.



Here is the same flake removed from the rock. Note that it is a portion of that same spall cone we looked at in the beginning when a BB hits plate glass. Doc will simply remove more portions of similar cones at places (and sizes) of his choosing, until he ends up with the desired results.



Here Doc has removed the second flake, overlapping the first and along the edge ridge he created with the first flake.



Here's the rock after Doc has carefully removed almost all of the outer layers (the cortex). Note a little of it still remaining at the right hand end. The cortex is highly weathered and doesn't have that characteristically shiny obsidian surface. The rock is becoming more and more convex in cross section, which is Doc's ultimate aim. Flakes will travel very well over a convex surface, and convex blades have the best characteristics of both strength and sharp edge for durability.



As the edges become thinner and sharper, Doc is paying particular attention to thickening the incredibly sharp edge by abrading it away with a coarse stone. Modern knappers use pieces of grindstone, where prehistoric knappers would have used coarse sandstone. Thickening the edge allows the force of each blow to transfer efficiently into the stone, resulting in a clean break, in the desired place, rather than allowing the sharp but weaker edge to crush. Crushing either fails to detach a flake, or only allows the break to travel part way into the stone, then break off leaving an ugly ledge which will be very difficult to deal with later (a common beginner's mistake). A not to be overlooked advantage to abrading the edge is the stone is much safer to handle. Freshly flaked edges are so sharp you can easily cut yourself and not even notice until the area around you begins to fill with red fluid!



Here's the rock several series of flakes later, at a stage called a "biface." This is the stage at which Native Americans would have used to transport the stone for trading or taking home. Rather than carrying a lot of waste stone (remember, no pickup trucks back then), Native Americans would have reduced the raw stone to this stage, and carried them away in baskets. From this stage, a large knife blade or spear point could be produced at will, and most of the subsequent waste flakes taken off would be recycled as small cutting tools or arrow points.



Here it is from a side view. At this stage, the rock is at least half the weight of the original.



Here's the next stage. Doc has continued to go around the edges and on both faces of the stone removing flakes to further refine the shape. He's been paying especially close attention to removing flakes to help thin the stone.



The same stage edge on. Note how much thinner it is.



Several more rounds of thinning and shaping flakes. Note how much it is starting to look like a knife blade.



Same stage edge on.



More refinement. Doc's carefully programmed flake removals are starting to show up regularly spaced and matching with flakes from the opposite side. Knappers would refer to these as well spaced flake scars. Nicely patterned flake scars produce prettier blades, and are often considered a demonstration of the knapper's prowess.



Edge on. Only a few places to fiddle with and we'll be done.





Here's the "debitage" (waste stone) pile left after finishing the blade. Many of these flakes are useable as cutting tools simply by abrading the side held next to the hand (for safety), or to be made into smaller knives, arrow points, drills, scrapers or other tools. This is also the amount of material a Native American trader would not have had to carry when he (or she) took out only biface stage material.



The finished 7 inch blade. Note the evenly spaced flake scars, matching with other scars from the opposite side, and smooth edges. A beautifully knapped knife blade, or with several notches at the wide end, hafted onto a spear. All told, several hours of intense concentration, and lots of years of practice in the school of hard knocks, cuts, scrapes and jabs.



All contents copyrighted © 2002 | Tom Sterling

Tom Sterling PO Box 1621 Coupeville WA 98239

---

From: [ww.sterlingsculptures.com/Resources\\_folder/Knapping\\_folder/Knapping\\_6.htm](http://ww.sterlingsculptures.com/Resources_folder/Knapping_folder/Knapping_6.htm),  
March 31, 2010, copied with permission

# Abo Flintknapping Reduction Strategies

by Rick Hamilton  
Spirit in the Wind Enterprises

A photo essay on abo flintknapping reduction strategies and techniques utilizing hammerstones and antler billets.

## Some notes by the knapper:

This particular piece of Niobrarite had a seam which came apart on me about halfway through the reduction process, resulting in a smaller biface. This triangular cross sectioned, tabular piece would have been very difficult to use a modern lapidary saw on with much efficiency. I picked this piece as it was triangular shaped, with two square edges, and cortex on each face, which allowed for a variety of reduction techniques.

I first edged the piece, than used longitudinal primary flakes from the proximal ends to thin and flatten the piece. Then I proceeded to percussion flake removal from the sides. Efficiency is the key to a good reduction process. Your flakes should travel as long as possible. Bob Patten taught me to look at my debitage pile when I was done. If you have mainly large thin flakes you have done a good job. In my opinion this is one of the major differences in antler knapping as opposed to copper and some of the other materials.

Most of the resulting debitage flakes can be used for arrow points and scrapers, or as cutting implements as is. Take a look at the last picture of the series to see the resulting debitage pile from this reduction.



A tabular piece of Republican River material a.k.a. Republican, Niobrarite, Smokey Hill Jasper, Smokey Hill Silicified Chalkstone. The piece is approx. 2 1/2" wide, 4" long, and 1 1/2" thick. The piece is triangular in cross section



The opposing edge showing an angle suitable for a large platform for initial reduction flakes.



Stitching is the process of removing flakes alternately from each face to remove a square edge. A hammerstone was used at this stage.



The opposing edge with a flake removed to help reduce the square edge.



An end view showing the triangular cross section of the piece. A challenge to thin while retaining the width on a piece like this.



A second flake removed from the base (proximal) end to further minimize the square edge utilizing a platform created by the previous flake removal. (the basic technique for blade removal). The platform was on the right hand side of the flake with an antler billet being used.



A hammerstone was used to stitch the remaining edge after the reduction of the two flakes from the proximal end to minimize the square edge



I used a whitetail antler billet and the platform shown to remove the flake and then put back in it's original position. This is the proximal (base) side.



A top view showing the same flake and it's removal scar. Notice it removed the majority of the cortex and traveled nearly the full length of the nodule.



Side view of resultant flake, notice it's flatness which is what you want on primary thinning flakes initiated from either the proximal or distal (point) end.



Opposing face (1) showing a flake removed from the proximal (base) end. It also removed nearly all the cortex from this face very similar to side 1. The flake did break into three pieces but held together enough to travel the full length. Removing your initial primary flakes from the ends thins while also maintaining your width.



Top view showing the flake removed in the previous photo. Notice the chalky portion in the center. There is a seam in there that would cause me problems later on.



A full length or in this case a full width flake (coast to coast) without dipping into the ocean (overshooting). These major secondary flakes are initiated from the sides using some of the platforms created by the earlier stitching of the square edges. Notice the stitching remnants on the edge in the bottom of the photo.



The same flake from a different angle. The platform is on the right hand side of the flake.



This platform is too large for a billet, the piece would probably break. I used a hammerstone to remove a small flake from the bottom on either side of the platform, which created a smaller one that I then removed with a billet.



Initial pressure flake removal to help regularize edge and also to set up more platforms for more percussion flake removal with a smaller antler billet.



The biface after the target thickness has been reached. Percussion has been used almost exclusively to this point. I lost nearly half of the biface just prior to this due to a seam which is quite common in this particular material.



I prepared isolated platforms at this point such as the one above using an antler tine pressure flaker to regularize the edge and also to remove ridges and extra mass.



Isolated pressure flaking platforms created by alternate pressure flake removal from each face while progressing unidirectionally down the edge.





The top half of the biface has been pressure flaked using the platforms shown in the previous photo, I now will create platforms on the bottom edge and pressure flake the remaining half of the face shown. Notice the percussion scar remnants on the bottom half.



We now have a thin biface with nice convexity which could be finished with pressure flaking in a minimal amount of time.



All the primary, secondary, and tertiary flakes from the reduction process to this point. A few of the pressure flakes escaped on me, but for the most part this is the complete debitage pile from the reduction process. These would all have been used as tools or as blanks for points, scrapers, etc.

---

From [http://www.spiritinthewind.com/abo\\_flintknapping\\_reduction\\_stra3.htm](http://www.spiritinthewind.com/abo_flintknapping_reduction_stra3.htm), March 31, 2010, copied with permission

## Using a Rocker Punch

By Lucas W. Nicholson (aka goose)

Okay.....I took some pics using the rocker punch. A couple are a little blurry, but they should get the point across.

The first one is a pic of the flake I intend to take. My finger is on the platform I'm going to use and it points in the direction of the indirect blow. Notice the spur I left on the opposite face? That is something I do when I plan on getting an overshot. Or in case I get a shorter undesired flake I can remove the remnants from the opposite direction. The spur allows for correct contours and edge thickness and allows the flake a place to dive (when struck correctly). It did not work perfectly in this case as you can see.



This is just an on-edge-view of the biface and the platform. Notice how the platform is lowered and well isolated.



Another pic showing the isolated platform.....



This pic shows everything ready to hit. I am pushing to the right with my left hand and pushing to the left with my right leg. This amount of pressure needs to be adjusted according to the size of flake being removed.



A pull away view just before striking.....



A side view showing approximate angle of punch placement relative to the notch.



A close-up of the notch placement. When seating the punch listen for a "click" and then visually check to make sure your punch is making a sort of spread out contact with the platform. This can be done by slightly rotating the biface angle back and forth until it is just right. What you don't want to do is have the punch just make contact with the very edge of the platform in the back of the notch. This will cause a portion of the platform to shear off resulting in a short flake and what would appear to be an overstrike.



The flake.....



The flake scar.....



These are the tools I used. I would advise against using a carborundum abrader. It will only hinder your progress and allow you to cheat. For this method I used two hammerstones: one for abrading and a narrow one for finite isolation.



From <http://paleoplanet69529.yuku.com/reply/278203#reply-278203>, April 4, 2010, copied with permission

# Punch Process Pictures

Marty Rueter (aka Just a Flake)



I start on this irregular, raw chunk of burlington chert by trimming one corner of the edge down steeply. I can start with the punch at this point, but it made sense just to start by removing a large spall with a medium sized spherical hammerstone of hard sandstone. There is a pencil line at about the place i am going to strike this beveled edge. note how steep the bevel is and how high I am striking the margin. Edges like this are ideal for early spalling with hammerstones, although since so much thickness is removed with these flakes it is not ideal to remove them from the middle of the rock early, unless the ends are naturally tapered. Notice how steep the angle is in the below photo.



Here is the spall that is removed below. It is worth mentioning that this high margin strike, though safe on raw chert is more risky on heated material.



Now that this large flake (spall) is removed I can use the ridge created on the left side of this flake to begin doing the punch work. The punch work in this case is going to be aggressive. Here is the first punch platform following the ridge. Notice how the platform is seated in the notch of the punch. I strike the end of the punch on top and support the preform in my hand firmly. I apply slight pressure to the punch into the edge.





Here is the large flake that is removed. The punch I'm using is a small moose antler. I will only use this punch for the largest early flakes. I will switch to the white tail punch shortly. An alternative to the small moose punch would be a very large deer antler or elk antler



Our platforms for the punch are going to be lower than we strike with the hammerstone. Early platforms can be isolated spurs on ridges or just continuous lowered edges. The next photo shows three flakes taken from the other side of the preform along a beveled edge. This beveling was done with the hammerstone.





I continue the same process, building more isolated platforms as the edge gets thinner. I attack thickness from the ends as well







At this stage, the punch can be used to trim edges and set up platforms. As the preform edges become more acute, the notches in the punches need to be smaller, or unnotched punches can be used.

---

From: <http://www.flintknappingtips.com/processpictures.htm>, accessed 10-11-10, copied with permission

# Getting Better with Antler Punch

by Benjamin Eble

After numerous false starts, I finally have begun to get the hang of the antler punch. On my fifth biface, I started taking off "blowout" flakes from the edge, that remove humps, ridges, and even undercut multiple steps.

As I always intuitively felt, the biggest issue with using the punch is support. The punch takes a longer frame of time to load. And, during that time frame, the stone cannot be allowed to move.

Also, another issue which took a long while to figure out is that the normal swinging motion employed when using hammerstones, is not the best motion to use, when employing a punch. Rather, the punch needs a good pop. And, that pop needs to be a hard pop, at a high speed. I say "pop" because the normal hammerstone swing anticipates follow through, whereas a "pop" is a sudden acceleration that is not intended to go very far.

Another interesting thing about using a punch is that I have found little need to vary the size of the punch. Why? Because, the biggest determiner of the flake result has to do with the mass of the punch's percussor - the hammerstone. In other words, with the same punch, a bigger hammerstone produces bigger flakes. So, instead of varying punch size, it is more a matter of varying the hammerstone size.

Currently, I am using a large rectangular tab hammerstone that is easy to swing at a high rate of speed. The advantage to using a long hammerstone, over a round hammerstone, is that you can increase swinging speed, prior to the strike, by the long hammerstone's arc.

As for the punch, it is small. It is made from the base of a deer's antler. It is about four inches long, and around a thick inch at one end. The other end is narrower, and nearly rectangular. Each end is highly compact, and almost smooth from use. There are no discernible signs of wear, in spite of the fact that the ends have been used for hundreds of blows. Also, the antler is small enough so that it can be held with the thumb, and finger, of one hand - which is really important.

In struggling to get the punch to work, I had to get over a few hurdles, some of which have already been mentioned.

In looking at the setup, it seems that there are about five critical variables that all must be controlled simultaneously. And, I find that thinking about it from bottom to top makes it easier to understand, and control.

The first is that regardless of how you are seated, whether in a chair, or on the ground, the biface must be positioned on something. In both cases, I used my leg as the support, except when engaging in really hard punching.

With the biface on my leg (on a leather pad), the biface is still too mobile to punch. So, to secure the biface, I found the following four steps to be very helpful.

First - with the left edge of the left hand, push down on the left edge of the biface. This will cause the right side of the biface to protrude upwards.

Second - while pressing down on the left edge of the biface with the edge of the left palm, hold the punch between the thumb and first finger (or second finger), of the same hand.

Third - use the fourth finger, to pull upwards on the right edge of the biface, while holding it down with the palm.

Fourth - with the thumb, and first finger, hold the punch, and press the punch down on the platform, on the right edge of the biface.

There are three forces at work here. The first force, is the pressure used to hold the biface down. The second force is the pressure from the fourth finger pulling up on the underside of the biface. And, the third force is the force applied by the punch, while pushing down on the platform, while it is being held between the thumb and first (or second) finger.

Now, if you apply each pressure in consecutive order, the biface will become "locked" into place. In locking the biface into place, you can press the left down side of the biface into the support, by pushing it into the support with the punch. This will help to further immobilize the biface. Meanwhile, be sure to keep pulling the right edge of the biface up, with the tip of the fourth finger, of the left hand.

When everything feels tight, and solid, whack the end of the punch with a hammerstone held in your right hand. When you whack the punch, give it a real fast rap, or pop. Use a hammerstone that can be swung quickly, and has plenty of mass. (After detaching flakes for hours, I discovered that the fast popping motion used to hit the punch made a tremendous difference in the flakes detached.)

Now, when you start, it is going to feel a bit awkward, at first. When one spot feels tight, another spot might feel "off". It takes some time to get the hang of aligning everything, and locking everything down with pressure. But, the more you practice, the more you will see that you start from the bottom, and move up, as each area is put into alignment.

Also, it is somewhat of a relief to almost never have to switch tools. A short antler cylinder is ideal for trimming the edges, and then reworking them, in order to create new platforms, which can be popped in "punch mode", after the biface is flipped over.

As for platforms, there are quite a few possibilities. In areas where there is a high spot, a ridge, or a bulge, you can trim the edge with fast direct blows from the antler cylinder. First, work lightly to remove the fine edge. Then work with more force to detach slightly thicker flakes. If a portion of the edge has a stubborn hard spot, switch to "punch mode" to punch it off. Then, when the edge has a stout platform just below the ridge, high spot, or bulge, flip the biface over, set up the punch, and whack real hard. If you have a significant bulge, or ridge to remove, you can lower the punch a bit, in order to angle the blow into the stone, a bit more. In this case, the leg hold might not be sufficient. And, there are other means by which the biface can be made more secure, while delivering a harder blow.

Also, depending on the situation (and platform), it is possible to use the punch effectively at nearly a right angle. A good analogy would be when a hard hammerstone is used to clip a biface's edge at a right angle, and the resulting fracture runs straight across the face of the biface. This can be achieved with the punch, but can require a really fast pop, plus the right contour on the face of the biface.

These are a few notes. I have taken some photos, which I will upload.



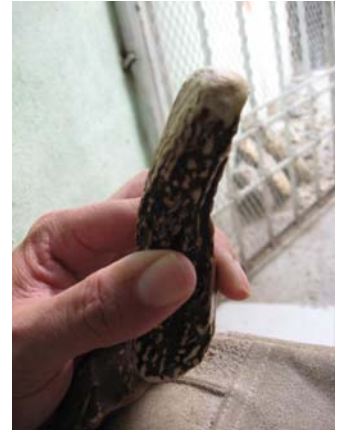



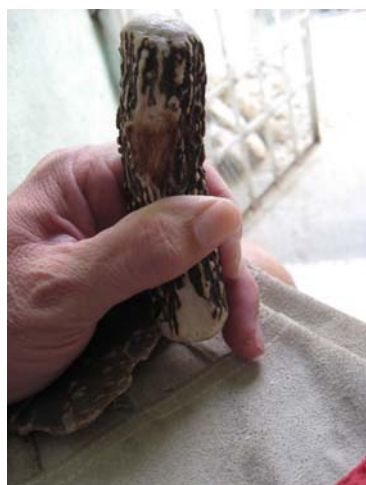

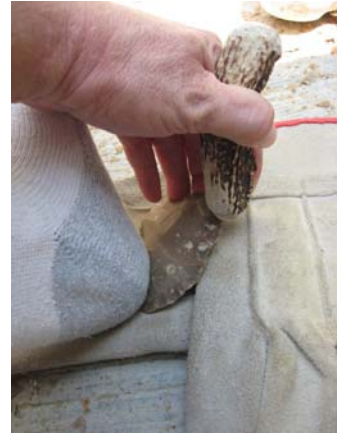

I think that my punch is a bit on the long side. I would look for a punch that is easy to hold in one hand, and is not too long. A longer punch is more prone to flexing, which can make it harder to detach flakes. Also, the tip of my punch is round, and probably an inch across. The tip on the other end is narrower, and wider. The other end also works good - especially in getting into enclosed spaces.

The punch also works good for "micro percussion", in trimming up the edges, and making platforms. So, I actually alternate between using the punch for percussion, and using the punch as a punch. In using the punch for percussion, I snap it straight down on the edges, to trim the edges, and rework them, to make new platforms. Sometimes, I trim the edges very quickly and make continuous platforms -which also work well for indirect percussion. The nice thing about using the punch as a percussor to prepare the edges, is that you never have to swap out tools.

Also, there are many techniques you can come up with, in using the punch as a percussor. I have found that in trimming the edges, a person can start at one point, by taking off microflakes, and steadily work along an edge to create a certain contour. This contour can include isolated platforms, which can be subsequently removed with the punch as a percussor. This leaves very even steep edged platforms which work well for the punch, in indirect percussion.

I would say that the really outstanding flakes - which are not seen in these photos - were created by using low, nearly vertical platforms, plus a punch that is set somewhat high on the edge, plus a pre-existing ridge on the other side of the platform, plus really solid support during the strike. If all of the factors are optimal, then the length of the detached flake will probably be determined by the contour of the flake's surface. A flake can run under a ridge, until the ridge flattens back out. At that point, the flake will simply feather out. These flakes tend to be narrower, and longer, and can span the face of the rock.

A flake can also run under a hump. But, these flakes tend to be wider than those that run under ridges. After this, there are flakes that are taken off places where the stone is already nearly flat. These flakes are generally not so great. For this reason, over a short three days I figures out that the original thinning passes that produce ridges are really important. Because, with these ridges, you can run longer flakes that help in the thinning process. Also, once a great deal of thinning has been achieved, the original ridges are pretty much gone.

Also, in using the punch to remove spaced out flakes from a single continuous platform, you will be left with very thick deltas. These deltas can be removed by using the punch as a percussor, and striking down on the edge of the delta. By moving carefully from the thinner side of the delta, to the thicker portion of the delta, you can carefully remove flakes in sequence which will allow for full removal of the delta. The result is a slight "lobe" where the delta was, which may be the same thing that is seen on some Clovis points that certain "lobes", carefully spaced on the edges.

Normally, I would revert to hammerstones to do some of this. But, I have found that the antler actually has some advantages. In "micro-chipping", and preparing platforms, micro-chipping with short thrusts from the antler, creates very clean even edges. Also, shattering is non-existent. So, a knapper can work on a really glassy stone, and create evenly contoured platforms, that

consist of flake removals, which are probably down to a millimeter in size. This can be done very quickly with the antler punch, as it doubles for a percussor, in "micro-chipping".

In looking back, I can see some real advantages to the punch over hammerstones. But, I think that hammerstones are still critical in another arena - the initial preform. A preform that is first wacked out with a hammerstone is going to have plenty of ridges, and high spots. If, at this stage, the knapper immediately switches to a punch, after the basic preform is created, the thinning process is probably going to be more easy to control. The punch rarely ever produces any kind of shattering - except maybe on really thin edges, with poor platforms. So, with a hammerstone made preform, the knapper could probably trim up platforms opposite each ridge, and punch off long blade like flakes to thin the stone, with great accuracy.

Another limiting factor with the punch relates to inclusions, or stone that is extremely hard. The Colha that I have been working on has it's share of inclusions. And, the thin delicate punch flakes tend to stop at times, when they cannot pass through the inclusions. On a few instances, I have had to revert to a quartzite hammerstone, in order to bust a flake through an inclusion when the punch failed. When this happens, the flakes will run up against "a wall of hardness" and stop. This will produce plenty of really nasty steps. And, the only solution is to upgrade to a really hard hammerstone, such as a quartzite hammerstone, and bust through the inclusion. For this reason, I am pretty sure that anyone using punches, in prehistoric times, would have looked for really good types of chert. It is really important that the stone is fairly even, and given to fracturing. I would imagine that obsidian would be ideal.

Also, if you look carefully at the photos, you can see that I am using my third, and fourth fingers, to support the biface, by pulling up on the edge. I prefer the fourth finger, simply because it is farther away from the platform. (Already, I have managed to drive a flake through the tip of my third finger.) Anyway, fourth finger support is really crucial to keeping the preform from bobbing during the strike. That finger support is what allows the flake to run much farther. Otherwise, the preform will simply bob downwards in the leather, on impact. Before I figured this out, I was hitting really hard, with little results. Also, I figured out that there is a workaround to using one's own finger. If the preform is placed on a flat, hand held stone anvil that is covered by leather, then the knapper can insert a small wedge under the preform, just next to the platform. This wedge/prop can serve to support the edge of the platform in an elevated position, during detachment.

---

from: <http://paleoplanet69529.yuku.com/topic/38697/t/Notes-Getting-better-with-antler-punch.html> and <http://paleoplanet69529.yuku.com/topic/38743/t/Photos-Punch-Experiment-Step-by-Step-3.html>, accessed 10-19-10

# Heavy Hammerstone Spalling – Tripod Setup

By Benjamin Eble



Large nodules are cumbersome to hold in one's lap. If they rest directly upon the ground, they can be very hard to spall. By creating a tripod, the large nodule can be elevated, and the back side of the nodule held down with a foot, while a really heavy hammerstone is used at a low speed to detach large flakes. Here is the nodule.



Here is the nodule in a tripod. (I am holding a flake in place by hand):



Here is another shot of the other end, with the support stone underneath:



Here is a shot of the heavy hammerstone. It is not a "two hander". But, it is pretty heavy:



With one foot on the back side of the nodule, and the nodule edge fairly low, I bring the heavy hammerstone down, and clip the edge at a low speed. A flake detaches. Here are the results:



Here you can see the corner of the flake, where I hit a fault in the rock. Too bad, or the flake would have been bigger.



The tripod support makes it possible to hold one end of the nodule down with one's foot. By using two support stones, it is possible to create support without a direct support that would impede the progress of the flake, while holding the nodule off of the ground. In my case, the flake hit a fault and stopped. Also, by using a really heavy hammerstone, and clipping the edge, it is possible to detach at low speeds, with less shock, shattering, etc. Also, there is absolutely nothing magical about my hammerstone. In fact, it was not a hammerstone until I used it as one. For people who have never used hammerstones, I hope that this tutorial is of a help. Ben

---

From <http://paleoplanet69529.yuku.com/topic/32201>, April 4, 2010, copied with permission



# Ball Flint Reduction

By Gary Merlie

Since I live in the southern half of Illinois, I have been fortunate enough to hunt and work ball flint from Illinois (Cobden), Indiana (Wyandotte), Kentucky, (Wyandotte and St. Genevieve), Tennessee, (St. Genevieve and Ft. Payne) and even some ball Burlington from St. Charles, Mo.



Here is our guinea pig for today, a half ball of Wyandotte from Breckinridge Co. Ky, that Jeff Shelton and I dragged home from the creek a couple years ago.



I first take flakes off all the way around the core to remove cortex, using the flat face as a platform. Continuing like this will produce the so-called "core-struck blades". A large nodule with good mass will produce flat blades. As the mass decreases, the blades start coming off curved.



Crossroads: You can go two ways from here. You could continue removing blades from the core, using the flat side as a platform, until it is becomes an exhausted polyhedral core. Or, you can use the side of the core as a

platform and remove flat flakes and spalls from the face. Pic shows one removal of each type.



I've chosen to remove a large spall from the face by striking the edge. Due to a bad center in the core, this spall only went half way across the face. No problem, as this is a good artifact size spall. The blow to remove the spall came from the upper right of the core.



I've struck off another spall from the face, striking from the opposite side. The core is now flat again, and I now have two spalls for artifacts.



Here's two more flat spalls/flakes taken off the flat side, again using the side as a platform.



As the core becomes reduced and flatter, (the so called "turtle-back") I eventually reduce it into a biface as well. This pic shows the yield from the 4" dia. ball. 3 usable spalls I've turned into bifaces. One unusable spall I discarded, and several flakes that will work up into nice bird points.



I chipped the 3 bifaces into points, and here is what I ended up with, a side notch, a fluted point, and a Thebes.



Depending on what you are setting out to make, flint balls can be an efficient use of flint or a terribly wasteful process. If you don't have a lot of ball flint to waste, and not many people do, I think these balls are best utilized by slabbing with a rock saw.

I hope this small presentation enlightens someone out there just a little. Post any questions you have, and I'll try to answer them if I can. Rockhead

---

From <http://opalvalley.com/gary/flint2.html>, May 2, 2006, copied with permission

# Dome and Plane Reduction

By Tony Baker

## Step 0--Flatten Face A

A large flake or spall removed very early after opening up a nodule was the beginning of the D&P process. If the spall did not have an acceptable flat face, then Step 0 had to be executed. If Step 0 was executed it was done only once because subsequent D&P faces provided the necessary flat face.

One way the New Clovis knappers accomplished flattening a face was with wide flakes that ran from edge to edge (outré passé). Flakes that travel from edge to edge remove any surface irregularities that might exist on that face. Bifaces 1 & 5 with their outré passé flake scars (left images) are classic examples of what I associate with Clovis. However, as I looked through the hundreds of bifaces that Carl had, I found few pieces like these. I was puzzled by the scarcity of this type of artifact until I began to understand the D&P process. Step 0 occurred only one time for any given biface, and sometimes not at all if a flat face was naturally present. Cycle 2 then obliterated the outré passé flake scars. Bifaces 1 & 5 are rare artifacts and one of the keys to understanding the D&P process.



## Cycle 1--Step 1. Dome Face B

Step 1 was the first step in the repeatable cycle. This step had the purpose of creating a dome on Face B. The dome must lie along the center of the face and run from end to end. Often in the first cycle there was a raised area resulting from creating the spall. With very little work on the face the knapper was able to modify this raised area to create a satisfactory dome. However, in subsequent cycles, considerable work was required to dome a face because it had been flattened by the previous D&P.



Left image of Biface 13 shows some of the work that went into the creation of the dome on a subsequent cycle. A regular pattern of flakes was removed from the edges of the biface. These flakes terminated at the center of the face thus creating the dome. To remove these flakes from the edge, the edge had to be turned or beveled to favor flake remove from this face. Each time the edge is turned to dome the other face, the biface becomes narrower. Since the knapper desired a biface with a large width to thickness ratio, they had to proportionally remove more thickness in the planing step than they removed width when turning the edge.

When the edges were turned to construct the dome, the proximal end where the planing blow was struck was also turned. As reported above, Sanders observed minimum platform preparation during the early biface stages (1990:45). His observations were correct, because during the earlier stages of planing, the LRCC knappers were employing off-margin striking (off-edge blow). Thick bifaces do not require the extreme accuracy of blow for successful planing so the knappers were saving time by not building platforms. The classic example of planing with off-margin striking is the creation of the Levallois flake.

In later cycles when the biface was thinner, a platform was constructed to be used as a target. This was done by positioning the margin (edge) at the appropriate distance from the face and then grinding it so it would not crush during impact. (The two conditions depicted in this image, off-margin and margin striking, will produce the same flake.)

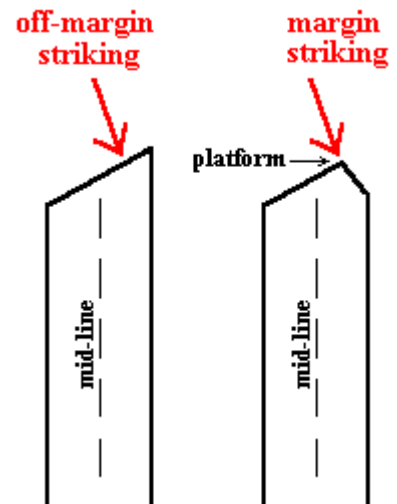

To reiterate, Step 1 contains three sub-steps: 1) turn the edge, 2) create the dome, and 3) create the platform. If each of these sub-steps is performed correctly, then Step 2 will almost always be successful.

### 1--Step 2. Plane Face B

Step 2 consisted of only one percussion blow that planed the dome created in Step 1. If successful, a single, wide D&P flake was removed from the proximal end to the distal end and a flat face that was parallel to the reverse face was the result. Because this single planing blow was responsible for a large portion of unfinished bifaces found in the archaeological record, I have chosen to make it a single Step in the dome & plane process. The most common fatal error while planing was the overshoot or reverse hinge as depicted in the right image of Biface 2. It was abandoned after the D&P flake cut it into two pieces. If the overshoot failure had occurred at a further distance from the proximal end the biface probably could have been salvaged. However, after this short overshoot the biface was too thick for its length and the knapper chose to abandon it.

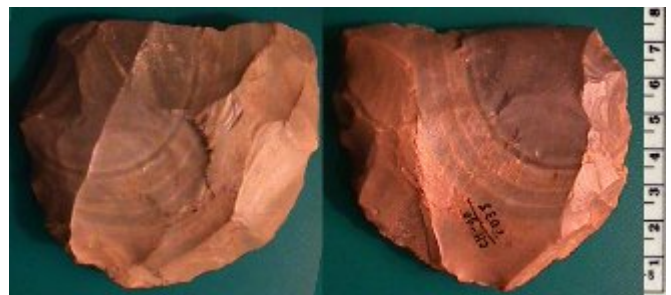

As stated earlier, successful planing is largely dependent on the flatness of the opposite face. Another way of saying the same thing, is the thickness of the biface must not change radically along its length. Sudden changes in thickness will almost always cause the S&P flake to hinge or reverse hinge at that juncture. Correct flattening of the reverse face yields a successful planing step.

**Cycle 2 and subsequent cycles**

At this juncture the biface had two flat faces. However, it probably was too thick, so the knapper just repeated Steps 1 and 2 again. Since both faces were flat, the knapper could in theory choose to dome the face he had just planed. The knapper could have even reversed the ends and plane from the distal end in the next step. All was possible after the two flat faces had been achieved.

---

From: [http://www.ele.net/Carl/flt\\_bifa.htm](http://www.ele.net/Carl/flt_bifa.htm), accessed 12-16-10, copied with permission

# Preventing Broken Points

© copyright 1996 by W.R. Knapp

It's so discouraging. Seems like everytime you get your points anywhere near a thin stage they break. They endsnap. They fold. Reaching your goal of thinner bifaces is just within your grasp and then it's snatched away in the blink of an eye. Well, I've been there. But I can honestly say that ever since I learned the things in this article, I haven't broken a single point while billet thinning as long as I didn't rush things and I took the time to apply the techniques. That brings up an important thing to remember. **There aren't any shortcuts** to creating those beautiful points. Besides, you don't want to hurry. Flintknapping is fun. Relax and concentrate on really seeing what the stone needs and you'll be happier with the results.

I learned the techniques described here from my good friend Jerry Ulrich, a knapper from Battle Creek, Michigan. After watching me knap a piece down to a 4 to 1 W/T (width to thickness) biface and then break it, he told me that there was no reason to ever break a point that had gotten that far. But I needed to memorize some things and practice them until they became second nature. I did what he said and he was right! I'll list them for you and then we'll discuss how to achieve each one of them. Here they are:

PLATFORM HAS TO BE BELOW THE CENTER LINE  
ISOLATE THE PLATFORM  
ABRADE  
PROVIDE SUPPORT  
DAMPEN VIBRATION

**Every time** you are going to strike a platform make sure you have done the things in the above checklist.

## *Platform Is Below The Center Line*

First thing is to make sure that the place where your billet is going to connect is **below the center line**. When you hit below the centerline, a flake comes off. When your preform is thin, and you hit above the center line, it is almost certainly going to break. As the preform gets thinner, it's very important to take a little time and really look at each platform you make. You need to make sure they're right. Do what you can to make every platform as perfect as you can and you'll be rewarded with more predictable results. As you gain experience you'll find that there are times where you might spend five minutes just preparing a platform but the results are well worth it.

### *Isolate The Platform*

Isolating a platform allows your billet to connect with certainty on the exact spot you wish to hit. It allows for concentration of all the force from that blow into that one spot. When using a moose-antler billet, striking properly abraded and isolated platforms results in large, fan-shaped thinning flakes. It's a great technique--especially for beginners.

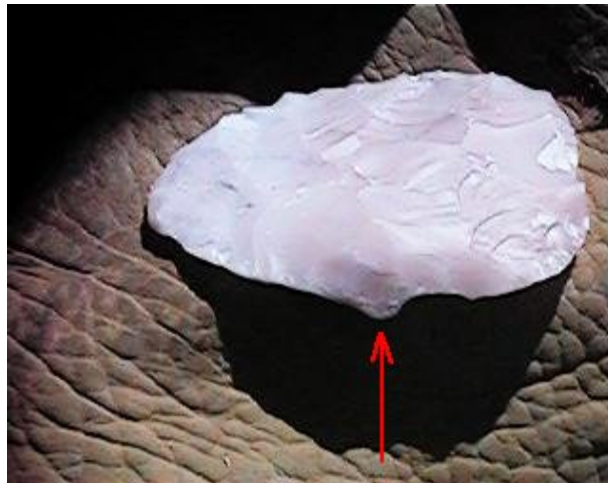

The above picture shows an isolated and abraded platform ready for the billet. I made this one a bit exaggerated so you can get the idea, but it will still work. You can see that some of the material has been removed from either side of it so that the billet will only catch the platform. Look at it! It's right out there beggin' for it. Don't you just want to hit it? Wait a minute, OK? Let's take care of a couple more things first.

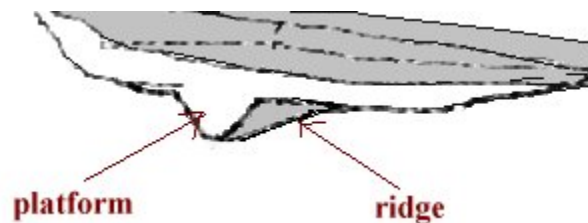

*Another example of a platform set up on a ridge. The platform has to be at an angle less than 90 degrees. The relative dimensions of the platform, ridge, and preform in this drawing have been exaggerated for clarity. As the preform gets thinner the platforms get smaller too. Everything gets more subtle as you near the final form.*



## Abrade

We talked a little about abrading in the last section. You also saw a picture of how our platform looked after it was abraded. We'll use this section to explain **why** we abrade.

Abrading is the rosetta stone of flintknapping. It's the "Eureka, I found it!" So many people who had to learn flintknapping by themselves have told me that when they discovered abrading they advanced "light years." There's good reason for this. An unabraded edge is sharp. It uses up the shock from the billet before it can do any good. Without abrading you end up with a crushed edge and a myriad of step-fractures. Abrading dulls the edge so that it has the strength to hold up under the force of the billet. On top of that, because you're hitting a blunted edge, the shock wave travels cleanly on through the stone. If you pay attention to the angle at which you are holding the piece, a long, wide, thinning flake results.

Here's another trick. Abrade a little on either side of your platforms. Then if somehow you do miss the place you intended to hit, at least you'll still remove a flake rather than damaging the edge.

### *Provide Support And Dampen Vibration*

We're in the home stretch now. The thinner your point gets, the more important these last two rules become. Here's how you hold a preform so as to provide support and dampen vibration when you hit your platforms.





The picture on the left shows how the bottom face of the preform is supported by the fingers. Only the finger that the knapper may be using to apply force for "pulling" a flake is actually applying any kind of real pressure. Mainly the fingers are there to support the whole point so that it holds up to the force of the strike. They also assist in dampening vibration. By the way, don't let your thumb clamp down and put force on the middle of the point. Let it rest closer to the back edge of the piece. That way it doesn't stop the shockwave halfway through and break the piece.

You will notice from the pictures that I like to use a piece of real leather chamois to protect my hand during knapping. I like how it's easier and less bulky to use than a glove and because it's so thin I believe you retain some of the "feel" that a bare handed knapper has. I can't explain this "feel". But you will know what I'm talking about when you "pull" enough flakes and feel the sensation of the shock from the releasing flake. In addition the leather supports the piece in the areas between your fingers and further helps reduce vibration. You double or triple the thickness in areas of the hand where an edge is seated. I strongly recommend protecting your hand- especially for beginners who are getting used to how knapped stone behaves.

The picture on the right shows the billet pressing **hard** and **inward** on the outside edge of the biface. What this does is firmly seat the "back" edge against the hand. Dampening the opposite edge to the one you are hitting does something to the shockwave as it travels through the stone that helps prevent the point from breaking. On Craig Ratzats video "Caught Knapping" he uses this technique to prevent "endsnap" when hitting the base of a point he was working on. He pressed the end opposite the one he was going to hit against his leg. If you are just holding the point out there without dampening the edge the shockwave does a mean trick and folds the piece or, if you are hitting the base or the tip, it does the "endsnap torture" trick.

After you have seated the back edge it's time to hit your platform. Now before you hit your next platform go through the above list again and then..smack it!



*The result of the strike using the techniques described here. The flake was 3 1/2 inches long and traveled all the way across the face to the other side.*

Well, there you have it. I think you are going to be very happy with the results if you take these techniques to heart. Using these rules my bifaces went from W/T ratios averaging around 3.5 to 1, to being nicely thinned pieces in the 6/1 range in the course of two weeks-and they're getting thinner. Let me know if this helped you and Happy Chipping!

---

From <http://www.onagocag.com/break.html>, April 1 2010, Copied with permission

Note: Wyatt R. Knapp is the author of "The New Atlatl and Dart Workbook" to be released Summer 2010.

## Some Talk About Angles

© copyright 1998 by W.R. Knapp

Okay...by now you've learned about herzian cones. You know that it is a cone shaped shock wave with sides that expand outward  $130^\circ$  to the point of impact on the stone. You know we use this shock wave, created from a billet strike, to make flakes come off knappable stone. But now we need to learn how to "cheat the angles" to make the best use of this shock wave.

After much practice you have probably standardized your billet swing so that it is coming down at pretty much the same angle all the time. This swing has become natural to you. You are hitting your platforms pretty much the same every time. Since this swing has become a constant, we have an opportunity to have some control over the thinning process and the length of the flakes we take off.

If you tilt your preform at different angles you can control how long your flakes are and how much material you remove. Depending on how much material you are trying to get through you may have to adjust the power of your strike as well. But a lot can be accomplished by understanding how to use different angles. The illustration below depicts a preform as viewed from the base end. The angle of the strike is indicated by the red arrow. Let's see how the shock wave travels through a stone that's held at this "flat" angle.

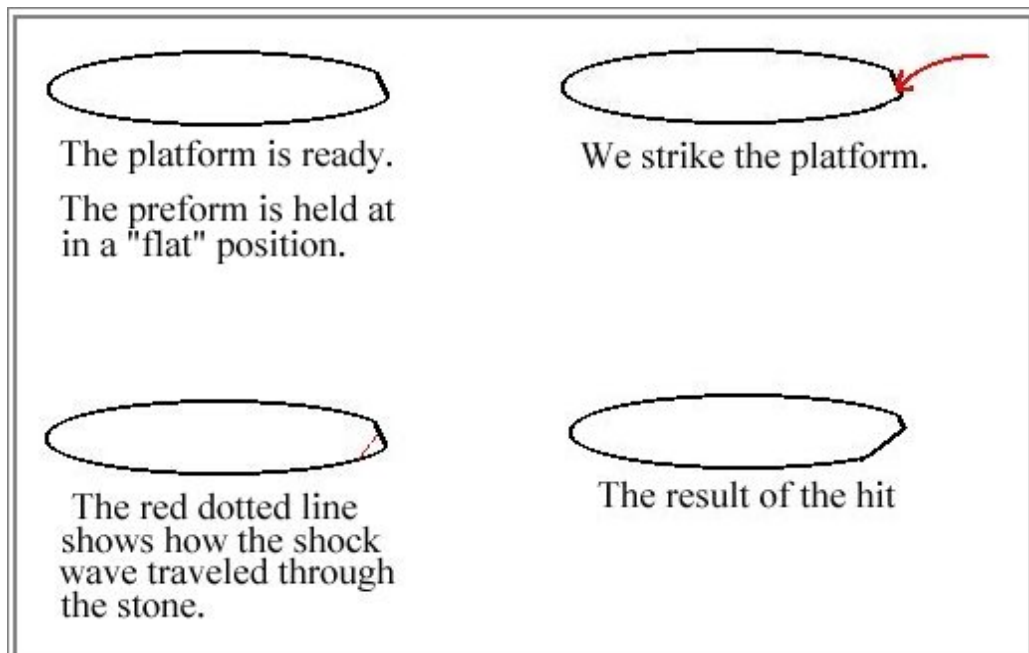

Well, the flake came off. And as you can see, we ended up with a rather shallow result. If we continue hitting our platforms with the preform held at this angle, it will get smaller and stay thick. We will get points that look like "turtle backs." This won't do will it? Well, let's change the angle we hold the preform at and see what happens.

In the illustrations below we take the same preform we had before and start all over with it. The angle of the strike is exactly the same as before. The resulting shock wave is at exactly the same angle as in the first example too. The only thing different is that this time we're going to change the angle that the preform is being held at. Let's see what happens.

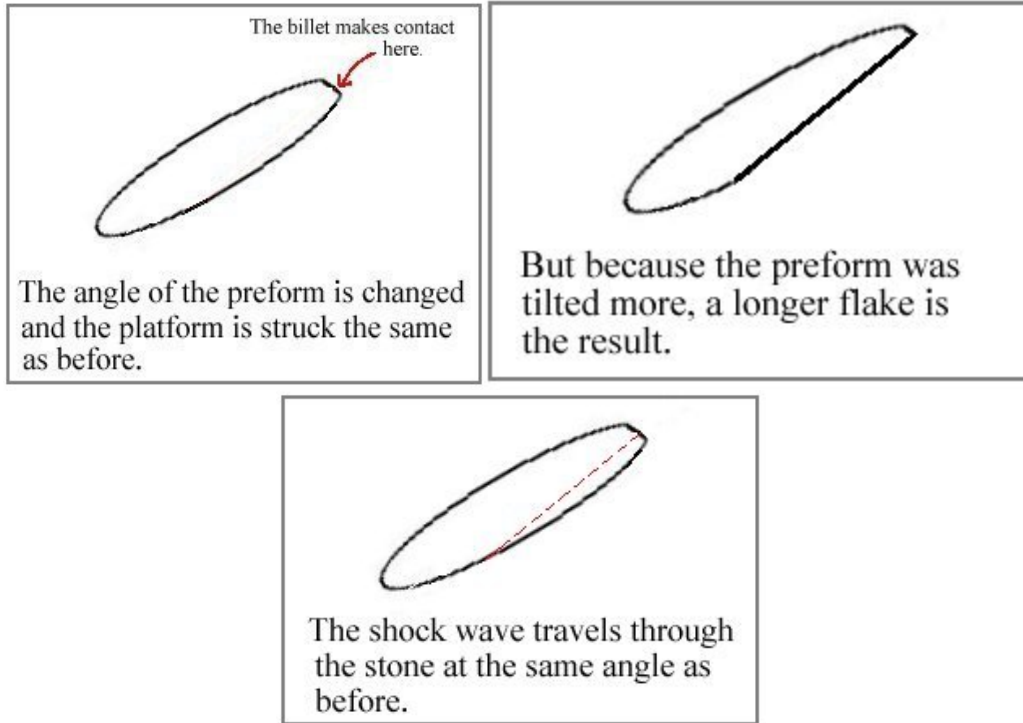

There we go! Now we took a nice bite out of it and got a flake that went right across the middle. If we keep this up the point will get thinner way faster than it gets narrow. By changing the angle we hold the preform at, we can control how thick and long the flake is that we take off. Just don't hold it at too much of an angle or you'll get a hinge or worse--you'll break the preform in half !

Now I should say that the angles that we showed in the illustrations are just examples. They might work for you. They might not. It depends on the angle of your billet swing. But just experiment with how you hold your preforms and see what angles work for you--and then all you have to do is practice enough to remember them.

Judicious use of this idea can really help you to "take the cap" off those really chunky pieces. Good Luck !!

---

From <http://www.onagocag.com/angle.html>, April 1 2010, copied with permission.

Note: Wyatt R. Knapp is the author of "The New Atlatl and Dart Workbook" to be released Summer 2010.

# Why You Should Work The Ends and Then The Middle !

© copyright 1997 by W.R. Knapp

My friend John Geyer told me as a beginner to "always work the ends first, then the middle." Of course I didn't quite catch on right away. Too many things to absorb. And with all the herzian cones and angles and platform isolation there's a lot of abstract visualization going on anyway. Well you don't have to worry...I'll show you right now what he meant.

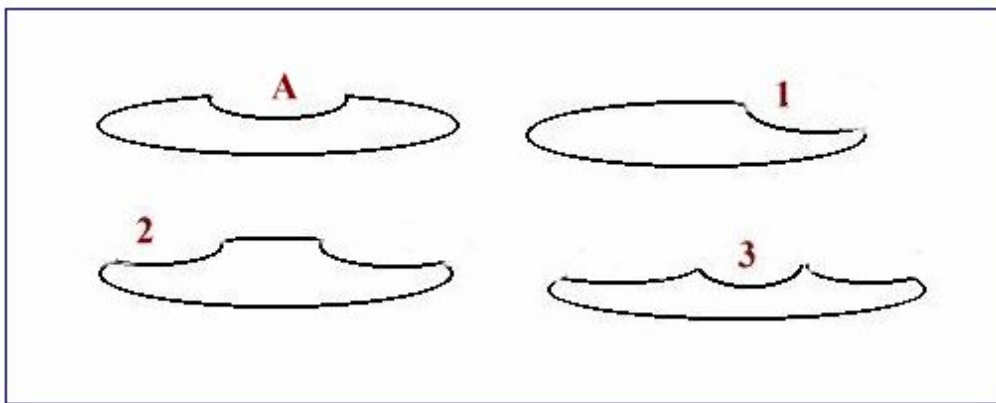

Look at the above illustration. If you were to take a flake out of a preform so that it ended up like figure "A" what do you think would be likely to happen on your next strike? Well, because the preform is so narrow in the center compared to the rest of the preform, it is likely to break in half. Now I drew these examples a little exaggerated for clarification. A real life example could be a lot more subtle. But the result would be the same.

But there is a solution to this trap! Work the ends then the middle. Our first move would be to thin the end like we see in figure 1. Then we would go to the other end and work on that. (fig.2) Finally we would work the middle (fig.3), because now that it has enough bulk to stand up to the strike there's less chance of breakage. And look at the added benefit we achieve. Nice ridges to follow on either side of the middle for our next strikes. When you plan your strikes like this you will notice a more deliberate and "right" look to the scar patterns on your preforms, and they get flat fast!

Now lets use all this on a real life example.

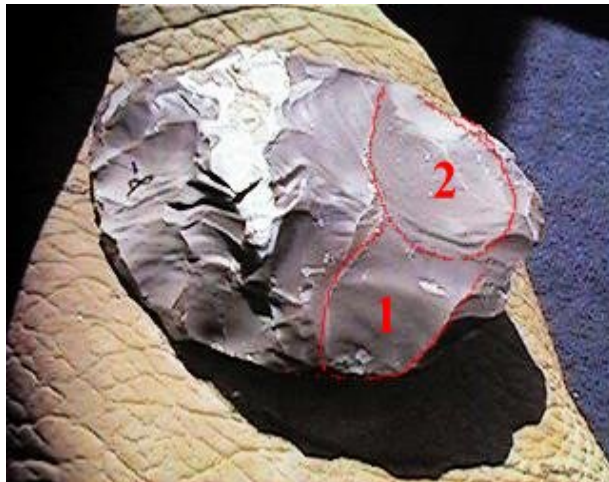

Flakes 1 and 2 are taken from the base end.



Flake 3 is taken off the tip.

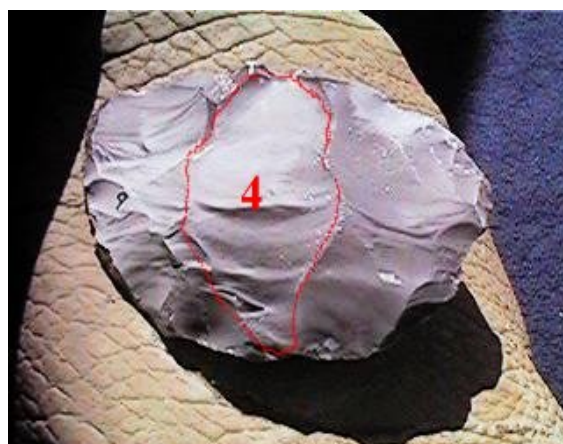



And now flake 4, the middle, is taken off. Because the middle had such a nice ridge, the flake flew clear across the piece--six inches. This preform is six inches wide and seven and a half inches long. but it has already become quite flat on this side with just a few hits because the techniques we have learned here were followed.

So see if it helps you to "work the ends, and then the middle." Good Luck!!

---

From <http://www.onagocag.com/buff.html>, April 1 2010, copied with permission

Note: Wyatt R. Knapp is the author of "The New Atlatl and Dart Workbook" to be released Summer 2010.



## Knapping on the Leg

© copyright 1997 by W.R. Knapp

Well, you've probably heard of it already, but I've used this method for a while now and I think its great. Its worth looking at why so many knappers are using it. It isn't the only way to knap, but I have found that I have better control and accuracy this way.

You see, quite often with freehand knapping you are holding your preform out in the air with one hand, and your other hand is holding the billet out there. Then you take your swing and you hope that you kept everything in position during that time and didn't flinch, or tilt the stone, or any of the hundreds of other variables that can occur.

Well, when freehanding it, you can cut down on these variables by resting the wrist of the preform holding hand on your leg. Then anchor the billeting arm by resting the elbow against the side of your body. This way you can adjust the "feed" of your preform into the anchored path of the billet swing.



But you can take it a step further.

Why not rest the preform on your leg where you can easily hold it at the proper angle. Your wrist won't change, the action of making your billet swing won't wiggle things and change them, and you won't flinch at the last second. Remember to still anchor your billeting arm as before. The more you can control the variables, the more accurately you will be able to knap.



*The picture above shows how easily the angle can be determined on the knee. The hand would then rest flat on the preform to press it into the pad and prepare it for the strike.*

The picture in the section below shows how this all comes together. Notice how easily the preform can be held at the correct angle.

---

From <http://www.onagocag.com/buff.html>, April 1 2010, copied with permission

Note: Wyatt R. Knapp is the author of "The New Atlatl and Dart Workbook" to be released Summer 2010.

## Buffalo Hide As Leg Pad and Preform Shock Dampening Tool

© copyright 1997 by W.R. Knapp

You probably noticed the buffalo hide leg pad in the above photos. This hint will work with any leather pad but the buffalo hide seems more supple and thicker, and more perfectly suited to this next tip.

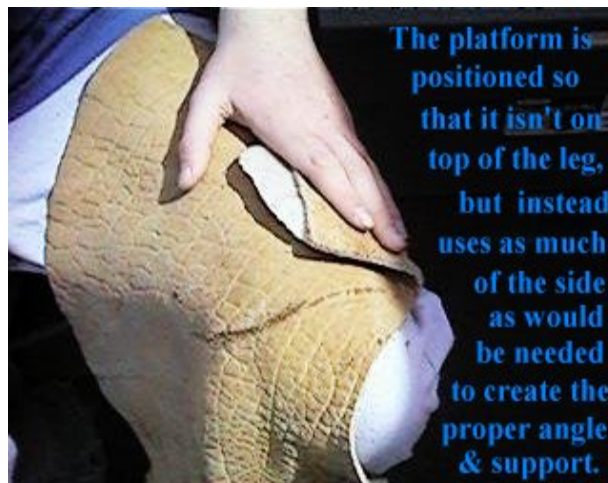

or

When knapping on your leg as described above, you have a very handy tool for support, and shock dampening. Just fold the edge of the lap pad over the preform as shown and seat it into the resulting pocket with your billet. Now when you smack the platform, not only is everything locked into the proper position, but the stone is supported and dampened, and the hand holding

the preform is protected. And you didn't have to pick up another pad or put on a glove to accomplish it!

Now there may still be situations where you would want to use the "pull" the flake technique and you would need to adjust your knapping style to accomplish it. But otherwise you may find this style of support helpful. (You may be able to "pull" the flake by pressing and pulling on the area from the bottom and through the leather.)

Knapping on the leg has been a great help for me. I realize that everyone has their own style. But if you have been having trouble with the accuracy of your strikes, or holding the proper angles, give this a try for several knapping sessions and see if you don't find it a big help. Many of the experienced knappers I have seen use this. And if you hit the platforms right you don't have to worry about hurting your leg because most of the shock is used up with the flake detachment. I don't get any bruises or sore legs.

---

From <http://www.onagocag.com/buff.html>, April 1 2010, copied with permission for free distribution only

Note: Wyatt R. Knapp is the author of "The New Atlatl and Dart Workbook" to be released Summer 2010.



*Photo courtesy of F. Scott Crawford*

## **Section 4: Pressure Flaking**

# Small Point Pressure Flaking

F Scott Crawford © 2009 All rights reserved

**Small Point Pressure Flaking; Edge Preparation Makes It Possible To Drive Flakes Beyond The Mid-Line, Thinning The Preform.**

Here we see the first sequence of pressure flakes on the smooth face of the chip. This surface usually has some curve across the face. Thinning flakes on smooth, curved material, tend to reach across the face nicely. I place the tip of the tool against the edge and build up the load of pressure. Then, snap the tip down while keeping pressure loaded. The flake travels in the line of the force at the instant the break initiates. So, I want the pressure to be reaching toward the opposite edge to produce a long flake removal.

1. Trimming edge to prepare pressure platform.  
2. Thick area below the line to be removed.  
3. Grinding to prepare the platform at the edge.  
4. Pressure on the platform edge in the thick area.  
5. The resulting flake scars on the smooth surface.  
6. Trimmed and ground opposite edge.  
7. Pressing at the second flake removal near the tip.  
8. Resulting flake scar near the tip of the preform.

From <http://www.arrowhead-makeyourown.com/>, April 6, 2010, copied with permission from "How to Make Your Own Arrowheads"

# From Beer Bottle to Arrow head

By Tim Rast

This page describes how to knap an arrowhead out of a beer bottle bottom. This includes breaking a bottle and working with extremely sharp broken glass.

**YOU CAN BE CUT AND SERIOUSLY INJURED.**

**GOGGLES MUST BE WORN AT ALL TIMES.**

**Kids, ASK YOUR PARENTS TO READ THIS PAGE BEFORE YOU TRY MAKING AN ARROWHEAD.**

---

Ingredients (required):

1 Beer Bottle (empty)  
1 Hammerstone  
1 Pressure Flaker  
1 Notching tool  
1 Leather Palm Pad (or heavy denim substitute)  
1 Pair Goggles  
1 Pair Heavy Leather Gloves  
1 LARGE box band-aids

recommended:

1 hammer  
1 tarp  
1 file (for sharpening the pressure flaker)  
1 abrading stone  
1 dustpan  
1 broom

## Step 1: Selecting the Bottle

Don't overlook the importance of this first step, finding a good bottle to start with will determine how successful your knapping attempt will be. The best part of the bottle to use is the bottom, because the glass tends to be thicker than the sides of the bottle, and much less curved. So when picking your bottle, pay special attention to the bottom.

1. **Colored glass is better than clear glass.** Its very difficult to see what you are working on when you work clear glass. Amber or green glass bottles work well
2. **Flat bottoms are crucial.** Wine bottles with big kick-ups are not good for knapping. Most bottles have some curvature to the bottom - its best to avoid noticeable concave bottomed bottles in favour of flatter bottoms. (This may entail switching brands of beer - so the decision is not always an easy one)
3. **Avoid bottoms with elaborate embossed markings,** like makers marks, numbers, or other designs. These lumps and bumps can be tricky to get rid of.
4. **Begin with a smaller beer bottle before you try a larger flat bottomed wine bottle.** They are less difficult to hold and its easier to cover a smaller surface with flakes than a larger one. You can work up to wine bottles.

## Step 2: Breaking the Bottle

Now you are going to need to break the beer bottle. You want to break it in such a way that the bottom will not be broken. Throwing it against a wall or rock is NOT a good way to start as the bottom is likely to break. Try wrapping it up in a corner of your tarp or a very heavy plastic bag and hitting the shoulder of the bottle with the hammer. NOTE: Wrapping the bottle up like this contains the mess, it does NOT protect you from the broken glass - The breaking glass can cut through the tarp and plastic bag quite easily. **WEAR HEAVY LEATHER GLOVES.**

Its easier to break a bottle by hitting it in the middle, but you have a greater chance of breaking the bottom if you hit it there, so strike the shoulder. If you don't have a hammer, try a hammer stone. Be very careful.

Alternatively, it is possible to cleanly pop the bottom off of a bottle by putting a nail into it (tip down) and shaking it straight up and down with your thumb over the mouth of the bottle. A bigger nail is necessary for wine bottles. I use a round file as a substitute. If successful, the bottom of the bottle will pop out as a sharp glass disc.

## Step 3: Cleaning the Hanging Glass off the Bottom

Unwrap your broken bottle. Hopefully the bottom will be in one piece. If it is, it will likely still be attached to sharp glass from the sides of the bottle. You will need to trim these hanging shards off, so that you have a nice flat bottom to work with. Hold the bottom upside down so that the shards hang down. **HOLD THE BOTTOM WITH LEATHER GLOVES OR WITH YOUR LEATHER PALM PAD.** Brush the hanging glass off with your hammerstone or the hammer. If you have a stubborn shard, try changing the angle you are holding the piece before you try striking harder. Don't brush too much, you just want the bottom to be flat - too much brushing will make nasty step fractures. Step fractures are failed flakes which break and end with straight edges, rather than gently feathering out. When you are done, look at the bottom and you will see "dents" on the inside of the bottle where you broke the hanging shards off. These dents are *flake scars*.

## Step 4: The Serpentine Edge - Alternate Flaking

Now the fun begins! To knap an arrowhead out of a bottle bottom you need to 1) make a bifacial edge, 2) cover both faces with flakes, 3) shape it, and 4) notch it (optional). Points 2 & 3 will be discussed in the next section, and you don't have to worry about notching yet. We are going to start by making a bifacial edge all the way around the bottle bottom. A *bifacial edge* is an edge which has been worked on both (bi-) sides or faces. Look at your bottle bottom. If you followed the instructions in step 3, you will only have flakes scars from





removed hanging shards on the inside of the bottle bottom, and none on the outside. Pieces worked only on one side are called *unifacial*.

Ok, lay the bottle bottom flat in the leather pad in the palm of your left hand (if you are right handed), and clamp your fingers down on top, to firmly hold the glass. It doesn't matter which side is up or down, just make sure that the edge you want to start working is exposed. You should have a little sandwich in your hand which goes; fingers, leather, glass, leather, palm. Now rest the back of that hand against the inside of your left knee for support. Using your copper flaker, you want to push down on the edge and detach a flake from the underside of the glass. Don't pry the flake off, push it off. You really have to push hard to get a flake to come off. If detaching the flake hurts or bruises your palm, double or triple up your leather palm pad.

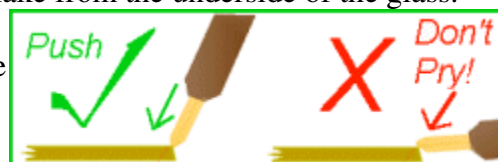

The flake removed will look something like a little half cone, and the flake scar will be a negative cone. You can fit the flake back into the scar to see what I mean by a *positive cone* (flake) and *negative cone* (flake scar). Ok, put your flake somewhere that people won't step on it and get back to your bottle bottom.

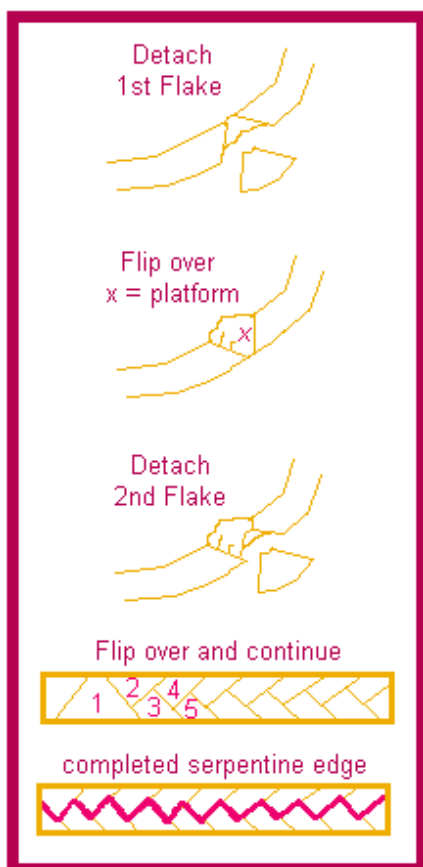

Flip the glass over so that the flake scar that was on the bottom is now on the top. You will use that flake scar as the platform for your next flake. The *platform* is the place where you place the tip of the flaker to push a flake off. You want to place the tip of the flaker to the left or right of the center of the flake scar, so that the next flake you remove will be off to one side of this first flake. Again, push down with the flaker and take another flake off. What you should have now is a bottle bottom, with two flake scars: one on each face. Now flip the glass over again and use the flake scar left from the second flake removal to remove a third flake. Continue to alternate flake around the entire edge of the bottle. When you are done you will have a wavy, bifacial serpentine edge!

### Step 5: Shaping

Now you have a wickedly sharp, bifacially worked bottle bottom. It doesn't look anything like an arrowhead yet - why? Its not shaped like one, either in cross-section or outline. The flake scars are only around the edge, they don't cover the face of the glass yet. You need to pressure flake it into shape. To do this, you need to change strategies a little. Instead of taking short chunky flakes off, like you did to make the serpentine edge, you need to take long, flat flakes off, which cover the faces of the bottle bottom, not just the edges. To do this, you change the angle you are flaking. Instead of pushing down, you want to push into the glass.

## Shaping - Cross-section

If you look at your beer bottle bottom from the side, you will see that it is now, more or less, hexagonal. It has two flat faces and steep bevelled edges. It will also have a slight curvature to it, with a concavity on the bottom face and a slightly convex top surface. Arrowheads are, most often, lens shaped in cross-section. To achieve this lens shape, you need to get rid of all the concave curvature of the glass. In the process you will also be covering the blank faces with attractive flake scars. Most of the work you need to do is on the bottom, concave side of the glass. It will be very tempting to remove flakes from the upper, convex side because flakes love to travel across convex surfaces. The flakes you remove from the bottom will be very short by comparison, but that's okay. They will get longer as you work at removing the curvature of the glass. Taking beautiful long flakes off of the upper, convex side of the glass will only make the curvature worse.

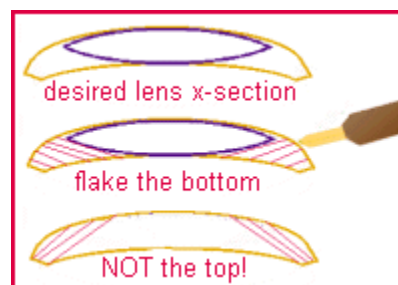

To remove the cross-section shaping flakes you will need to use the serpentine edge you've created. Creating the serpentine edge has made a whole series of platforms. The wavy edge zigzags up and down across the centerline of the edge. This is important. Your edge has peaks which are above the centerline and valleys which are below the centerline. (Check Wyatt Knapp's discussion of the "Below the Centerline Concept" for more detail) Your edge looks something like this:  $\wedge\wedge\wedge\wedge\wedge$  You use the valleys as platforms to take off flakes. Look at you glass and find the peaks and valleys. The valleys are the platforms. Imagine the centerline. Now flip it over. Find the peaks and valleys. Find the platforms.

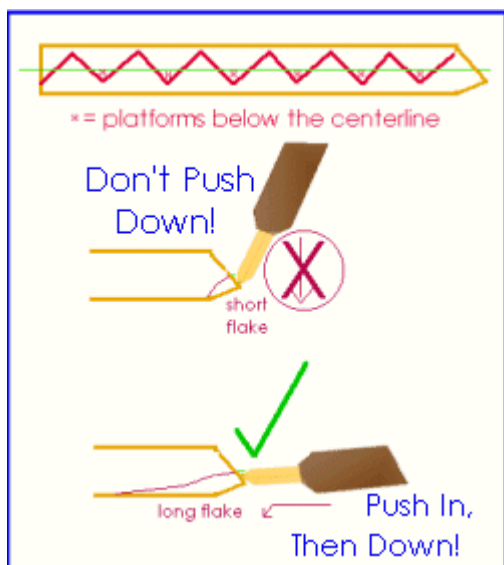

Hold the bottom in your hand, the same as when you made the bifacial serpentine edge. Make sure that the concave face is on the bottom. Find the peaks and valleys. Place the flaker tip against one of the valleys. Instead of pushing down, push into the glass. Push hard, build up a force and then push down a little to detach the flake. Remember push in, then down. Don't flip the glass over. Instead, move to the next valley and remove your next flake. Go all the way around. Then do it again. Don't be discouraged if your flakes aren't very long. You may have to go around the glass 3 or 4 or 5 times before the flakes reach all the way to the center. Everyone's flakes are short the first time around.

As you knap, your edge will get higher and your platforms (the valleys) will become less pronounced. So you will have to make new ones. You can do this a couple of different ways. One way is to use the tip of your flaker to brush up on the edge. This will remove tiny flakes from the upper surface of the edge (WEAR GOGGLES!). This will get rid of the thin brittle edge, making it stronger and

lower. The second way to make new platforms is to grind the edge with an abrading stone. I just use one of my hammerstones. Again, you want to prepare your platforms in the opposite direction that you are flaking. Flip the glass over, so that the face you want to flake is facing up and brush the edge, in a downward motion, with your abrader stone. Flip the glass back over, look for the platforms below the centerline, and keep knapping.

Keep this up until you achieve the desired lens shape. Remember to spend most of your time removing flakes from the concave side. It won't take you very long to cover the convex side with flake scars.

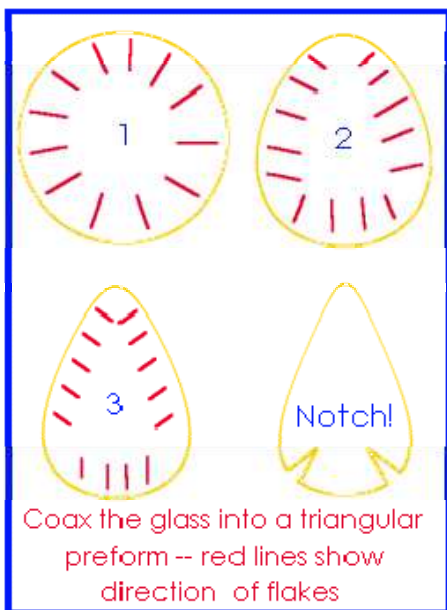

### Shaping - Outline

While you are working on the lens shaped cross-section, you will also want to coax your bottle bottom into an arrowhead shape. There are no hard and fast rules for shaping the outline of your arrowhead. If the bottle bottom is circular you can arbitrarily select a pointy end and a base end. Gradually change your circular bottle bottom into a triangle. If your glass is not perfectly round, look for the longest axis, and align your triangle along that. The first step is to stop thinking about the bottle as a circle and start thinking of it as a chubby triangle. Instead of working around and around in a spiral, work from three directions - in from the two sides of your arrowhead and up from the base. When you abrade your platforms, keep the triangle in mind and work towards that goal.

### Step 6: Notching

Wow! You made it - you have a lens-shaped triangular arrowhead. All you have left to do is notch it! The notching tools I typically use are sections of coat hanger mounted in broom handles, which have been filed to a chisel shape or copper wire which has been hammered flat (see the Pressure Flaker Page). Pick the point on the edge of the arrowhead where you want to start your notch. Use your notching tool to create a little nick in the edge, the same way you made your first flake on your serpentine edge. Flip it over. Take another flake off in the same place you took the first little flake off. Flip it over and keep doing it. It's the same sort of process as you used to make the serpentine edge, except you are flaking straight into the body of the piece instead of around the edge. Repeat the process for your second notch.

Tip: I like to make both notches at the same time, rather than finishing one and starting on the second one. I find that they turn out more uniform if I work on them together.

---

From: <http://www.cavemanchemistry.com/oldcave/projects/stone/bottle.html>, April 2, 2010, copied with permission

# How to Make Your Own Arrowhead

by Scott F. Crawford

© 2008 All rights reserved

Actually, ancestors of all of us used stone for hunting weapons for a very long time. The use of metal only replaced sharpened stone, bone and wood in the last few thousands of years. And then, in most of the world, the knowledge of “flint knapping” became a lost art. It wasn’t until the Europeans came to the Americas that Old World eyes once again realized the efficiency of stone arrow heads and knife blades.

## MAKING YOUR OWN STONE ARROWHEAD

All knapping begins with a piece of stone. Then you break away the parts of the stone which do not fit the idea you have in mind for the final product. This process is called reduction. The thing is, that once you break a piece off of a stone, you can not put it back. Unlike clay or metal, which can be reshaped, a stone tool is not moldable or bendable or malleable. You break it to change its shape.

To break stone you must obey the laws of physics. I think observant flint knappers first codified knowledge of the physical laws which provide order and predictability to the world around us. Much was discovered by trial and error, and then passed on to students from the masters of stone craft.

For the beginning knapper, making an arrowhead usually begins with a flake of stone. When you order the **Knapping Kit** from <http://www.StoneBreaker-FSC.net>, it supplies several flakes, or chips, of stone such as obsidian and flint. These may include chert from Oklahoma, novaculite from Arkansas, or flint from Texas, and obsidian from Oregon.

### STEP ONE

Select a chip from the materials in the kit. Also pick up the leather hand pad. It goes in either your left or right hand, as is appropriate, to protect the palm of your hand from small pieces which you will break off the chip. In addition, you will need either the antler tine or the copper tipped flaking tool. You can work on a bench top if you prefer,

so you can stand, or you can work in your hand and sit down. For the first time or two you may find working on a bench gives you better visibility and control.

#### ***First, a word about safety.***

*Use safety glasses and wear leather gloves. Work in an open, well-ventilated area when knapping, preferably outdoors.*

*Flaked stone is sharp. That is the point. Be careful with flakes, chips and tools. Always have a first aid kit at hand.*

Now, look at the chip. You will see that one side is smooth, and the other side has some ridges. The chip illustrates how this kind of stone breaks during the knapping process. When obsidian, or flint or chert or the other fine grained quartz stones are struck with a hammer stone or other implement at the correct angle, the resulting curved flake or chip will tend to follow the ridges on the face of the

stone. By harnessing this characteristic of knappable stone, we are able to break the stone in a controlled and intentional manner. The same rules of stone breaking at a large size apply to working with smaller pieces of stone. The only difference is a matter of scale. In addition to striking with a hammer stone, by applying pressure at the edge of the stone, at the beginning of a ridge line, we can “push” off a flake along

the ridge. This process is called pressure flaking.

This is the primary kind of force which is used to create an arrowhead from a chip of stone. Once you choose a chip, then we will proceed to prepare the edges of the flake so that you can apply pressure along the edge and push off small flakes.

#### **STEP TWO**

Choose which end of the flake you wish to be the point of the

arrowhead. When you look at the smooth underside of the flake you will see a bulbous shape, rounded and slightly higher than most of the flake surface, radiating away from the spot where the stone was struck to knock the chip off the stone. This is called the bulb of percussion.

Usually arrowheads are made with the pointed end at the bulb of percussion, and the base with its notches is located at the other end of the flake. The secret is to use the portion of the flake which is essentially straight. Flakes naturally have some curve, as the chip follows the contour of the original stone surface. Yet, if you look at the flake in profile, from the side along the lengthwise direction of the flake, you can see the natural curve, and you can see what portion of the chip could be used, allowing a straight line to the arrowhead.

#### **STEP THREE**

Now, we will use the antler tine to trim the chip to the general shape for the arrowhead. Lay the chip on the leather pad on your work bench. Place the smooth surface down. Then use the side of the narrow end of the tine to begin pressing at the thin edges, along the length of the flake, in a shearing motion along the edge. Hold the antler tine basically parallel with the edge and press down along the edge with the side of the antler. Do not overlap the edge except for a tiny distance, and press down along the edge, breaking off small pieces to trim the thin, curved edges into a straighter line leaving a thicker amount of material along the edge. Just press enough to break small pieces off. You will need to hold the flake in place, but do not press down on it too much, as you can break it. Odds are, you will break some flakes; that is why I am providing 12 flakes in the kit.

This trimming action can quickly provide a flake in nearly the size and shape of your finished point. You can trim it to straight edges in a triangular shape, or to curved edges in more of an oval configuration. Trim the base to fit your shape.

#### STEP FOUR

Next, you can use either the antler tine or the copper tipped flaking tool to begin sharpening your arrowhead. First, lay the flake down on the leather pad, to support the flake. This should be done with the smooth face of the chip up, so that the new flakes will be removed from the ridged face of the chip. This will allow you to press against the protruding or leading edge of the stone. You will place the point of the tool against this outer edge. But first, you should roughen or grind this edge a little by rubbing the side of the antler tine or a hard, slightly rough stone along the edge. This will rough up the sharp edge, providing better gripping surface for your tool.

Now, hold the piece in position with two or three fingers. Do not press too hard, just enough to keep it in position. Press the pointed tip of the tool against the edge. Generally, this first flake should be taken off at or near the tip end of the point. The force should be basically parallel the face of the chip, aimed toward the center line of the chip. Press against the roughened edge and then push a new flake off of the bottom face of the chip.

It takes a bit of pressure, against the edge, not against the face of the flake. You are essentially prying or pushing a small flake off the chip, running from the edge toward the middle of the chip.

After the flake comes off, turn over the point so you can see what happened. Your objective is a flake which runs to or beyond the centerline of the rough point. Many times the first flake may be short, but it will produce an edge along which your next flake will travel more easily.

For the second flake, move a little ways down along the edge and repeat the pressure process, overlapping the previous flake a little, so that the next flake will run along the ridge left by the first.

Do not press down on the chip too much while you are pressing against the side. Just enough to hold it in position. Too much pressure and you can break the chip at the

place where you are prying off a new flake. I know, as I have done this more times than I like to admit. It takes practice. And to know how much is not too much pressure, will also take practice and experience. This includes breaking an unknown number of points in the process!

Now, continue to remove additional flakes in progression along the edge towards the base of the point. Once you have worked your way along one edge, then work along the other edge on the same surface of the arrowhead. When you finish this side, you have what is known as a uniaxially worked arrowhead. These are often found, where the stone craftsman only flaked the point or blade on one face, and left the other side as a smooth surface, with little or no additional flaking on that side.

#### STEP FIVE

Prepare the second surface of the point for pressure flaking by trimming along the new edges. First remove the small triangular protruding edges between the new flakes. These are called "deltas" because of their shape. To remove them, press against their outer edge with the tip of your flaking tool. Just enough to break off the little triangles. Then use a shearing motion along the new edge again, in a motion parallel to the edge, pressing from the smooth face, just along the very edge. Just trim off a little bit of the thin edge, leaving a strengthened edge for additional pressure flaking toward the smooth face of the point.

Next grind or roughen up this edge line as you did before with the other side. This gives your flaking tool a better grip at the edge.

Repeat the pressure flaking process along the smooth face, beginning at the tip again, and working toward the base.

Now you have a basic triangular or oval shaped arrowhead.

#### STEP SIX

In ancient times, in many parts of the world, you would now be finished. These points were bound into either a split shaft, with glue and/or plant or animal fiber, or into a hollow shaft such as a reed with

glue and fiber. However, many points were also notched to facilitate the binding process.

So, you may wish to notch your arrowhead.

There are many different styles and methods. Side notch, corner notch, base notch, etc. Yet all basically remove material from the edge toward the middle, to make a groove or notch for binding.

The process is similar to preparing for pressure flaking, except that you will do this at just two places, in mirrored positions across from each other so that the point remains balanced and symmetrical.

First, measure where you want the notches, equally up the edge from the base or from the centerline along the base edge of the point, or at the corners. Make a tiny flake at the edge where you want the first notch. Then mark the other.

Use the sharp tip of the copper flaker to rough up the edge inside this marking notch. Just enough to get a grip with the tip. Push a flake off the underside of the point from the marking notch in the direction you want the finished notch to proceed. Turn the point over, rough up the edge of the notch and push another directional flake off from the other side. Repeat this channel flake process at the marking notch for the second notch. This will give you a series of guides for finishing the notches.

Now, trim in the end of the guide channel to create an edge to press out the next flake in the notch. You rough up the edge from one face of the point, then turn the point over to press the new notch flake off by prying against the newly roughened edge. Repeat on each notch until you have the notch you want. Do not allow the tool to touch the corners of the notch when you press inside the notch, as this will break off the corners of the notch, or more. Many knappers work a little on one notch, then the other, so that both notches progress evenly toward completion.

Voila! You have finished your own arrowhead. Congratulations.

Now, do it again. Enjoy.

<http://www.StoneBreaker-FSC.net>



1. Keokuk Chert chip, bulb of percussion is on the left end. Stone from Oklahoma.



5. Using the side of the antler tine to trim the edge to shape, in a shearing motion.



9. Next flake removed, you can see that the flake broke into a few smaller pieces.



2. Keokuk Chert chip, outer surface of the flake.



6. Holding in position to pressure flake; edge is trimmed and ground for tool grip.



10. Turn the chip over after each flake removal, so you can see the results.



3. Rough trim along both long edges and across the base, to general shape.



7. See where the first few flakes have been pressed off near the tip end of the chip.



11. First run of flake removals along this edge is complete. Examine your work.



4. Using the side of the copper tip to trim the edge to shape, in a shearing motion.



8. Copper-tipped flaker in position for next flake removal by pressure.



12. The removal of the flakes takes away most of the edge trim, as you can see.



13. Now the first pass along the other side has been completed. Whole side smoother.



17. A look at the smooth side of the point, while still working rough side, pass two.



21. First full pressure flaking pass along one edge of smooth surface.



14. After the new edge is trimmed again and ground for your tool to get good grip.



18. On rough side, completed second pass along second edge, see the "deltas" at edge.



22. First full pressure flaking pass along second edge of smooth surface.



15. Remove a few flakes to thin the bulb of percussion, and straighten the point.



19. On rough side, "deltas" removed, edge trimmed, preparing for smooth side flaking.



23. First full pressure flaking pass along base end of smooth surface.



16. Trimmed, and a second pass along the first side, removing the rough ridges.



20. Edge trimmed and ground, ready for smooth side pressure flaking.



24. Midway through full pressure flaking pass along second edge of rough surface.





25. Early in second full pressure flaking thinning pass, first edge of rough surface.



29. The rougher side, after another good run of thinning flakes along both edges.



33. This pass of thinning pressure flakes at the base of smooth side, too.



26. Fracture occurred from too much pressure, where chip was curved, also.



30. The smooth side, ready for another pass of thinning flakes along each edge.



34. Base of the rough side of point, prepared for thinning pressure flakes.



27. Trimmed to a new point, straighter now, ready for more thinning flakes.



31. The smooth side, after this pass of thinning flakes along the lower edge.



35. Base of the rough side of the point, after a series of thinning pressure flakes.



28. A view of the rougher side, before more thinning flakes will be removed.



32. Midway through this pass of thinning pressure flakes along the upper edge.



36. Base of the smooth side of the point, after a series of thinning pressure flakes.



37. Base of the rough side of the point, corners trimmed for notching process.



40. Rough side, notches completed, base trimmed for attachment to dart shaft.



41. On the smooth side, notches are completed, base is trimmed to finish shape.



38. On the smooth side of the point, long guide flake in upper corner, for notching.



39. Abrading tool and pressure flakers which can be used for making arrowheads.



42. On the originally rough side of the arrowhead, the notches are done, the base is trimmed to its finished shape, and a final trimming series of flakes balances the point.

---

From <http://www.arrowhead-maker.com/>, April 6, 2010, copied with permission

# Using Your Legs When Pressure Flaking

F Scott Crawford © 2009 All rights reserved

## Learning To Use Your Legs Provides Extra Power And Drive To Increase The Success Of Your Pressure Flaking Efforts.

I hold the chip in the palm of my left hand, on a leather pad. I seat the back of my left hand securely against my left thigh, close to my knee, for support.

My right hand is supported against my right thigh. I press the tip of the flaking tool tightly against the ground edge. And I hold the handle of the pressure flaker flat against the palm of my right hand.

By squeezing my legs together, I apply pressure at the tool tip into the mass of the material, with an orientation toward the underside face of the chip, reaching out toward the opposite edge.

While I squeeze my legs together, I also hold my right wrist straight and stiff, to keep the pressure of my right leg all concentrated in the tip of the pressure flaking tool, against the platform edge on the stone.

(Continued ...)



1. Pressure on prepared edge for rough-side flakes.

2. Inspecting the large flake scar on the rough side.

3. Pressure to remove flake near the tip of the point.

4. Another large flake scar, just before the tip.

# Why Use Your Legs In Pressure Flaking? Most People Have A Lot More Available Muscle Power In Their Legs Than Their Arms.

(Continues ...)

While the pressure is fully built up or "loaded", I snap or flick my wrist to initiate the fracture which pushes a flake from the underside of the stone chip.

As the flake releases, the pressure is still on the base of the flake. This helps cause the flake to continue breaking away from the stone, as long as the pressure

is maintained. Of course, this happens in an instant.

The "crack" of the breaking stone is a welcome sound, and an indication of a successful effort.

In the follow through the pressure flaker should land basically in a flat position against the leather pad, not pointing in to the pad. This final position also helps to protect your hand.



5. Ground platform on the opposite edge rough side.



6. Inspecting result of pressure flaking near the tip.



7. A new flake has just released under the chip.



8. Here is the flake scar of the previous photograph.

From <http://www.arrowhead-makeyourown.com/>, April 6, 2010, copied with permission from "How to Make Your Own Arrowheads"

# Why Pressure Flakes Fall Short

by Mark Bracken

There are several things to consider when your flakes fall short of your target or don't run as far as you want. All these tips below are complimentary to each other. They all pieces to the puzzle, they are all important.

1. The first is your **flake path**. What I mean is that you have to choose proper places on the bi-face that lend themselves to longer flakes. These generally are the highest places on the surface of the bi-face or preform. You must be sure that your choosing ridges and or humps to "guide" the flakes down.
2. The second thing is that you have to **grind** or buff up the edge with your abrading stone just enough to support the pressure your applying to the edge. Too much and it will take excessive force to generate a flake leaving you with a broken preform or a sprained wrist. If you do not grind enough, the edge can crush or create a small chip.
3. The third is that there is quite a bit of "body English" or **follow through** with the pressure flaker's or Ishi stick's use. What I mean is that when you peel a potato with a peeler, you follow the contour of the potato. This is because you want to create a shaving that is all one piece. This saves time and effort. So, with using the pressure flaker it is no different. You must guide the flaker in the same way. Place the flaker on the edge and slowly build up pressure, then as the flake begins to detach, with a "peeling" action guide the tool tip with a following through action.
4. The fourth thing is that flakes will travel farther if they are pushed in a **oblique** manner. (remember this critical rule...do not chip flakes down a surface that is concaved. It must have some amount of convexity.) If you can... try not to push them straight into the piece. (or a 90 degree angle from the edge) Flakes will rarely cross the center line on the piece.
5. The fifth thing is to **work in a row**. Like shelling corn of a corn cob. Start at the base or tip (depending on the way your holding it) and chip the flakes off in a row. Each flake following the other's scar. Sometimes you will need to skip an area because there is not a good path for the flake to travel on. With each pass down the preform it will become more uniform with less and less high spots.
6. Keep your flaker **sharp**! Your flaker tip can be a number of different types, paddle, flat, chisel, Pounded round to a point, or pounded round to a point with four square edges. The key thing here is that your contact area must be at a minimum. You can't do good pressure work with a dull flaker point. Remember to pound your copper tips NOT grind them. They will stay nice and hard. It's common for it to be necessary to re sharpen a flaker tip many times before the piece is finished.

---

From [http://www.flintknappingtools.com/flaking\\_tips.html](http://www.flintknappingtools.com/flaking_tips.html), March 31, 2010, copied with permission

# Slab Knapping Tutorial

By Mike Tylzynski (aka Idaho Clovisman)

"ok i will go out and turn the edge on a slab and post a picture..give me a few min..hope this helps now once you tell me you got this part i will show you the same slab set up for a complete pass..

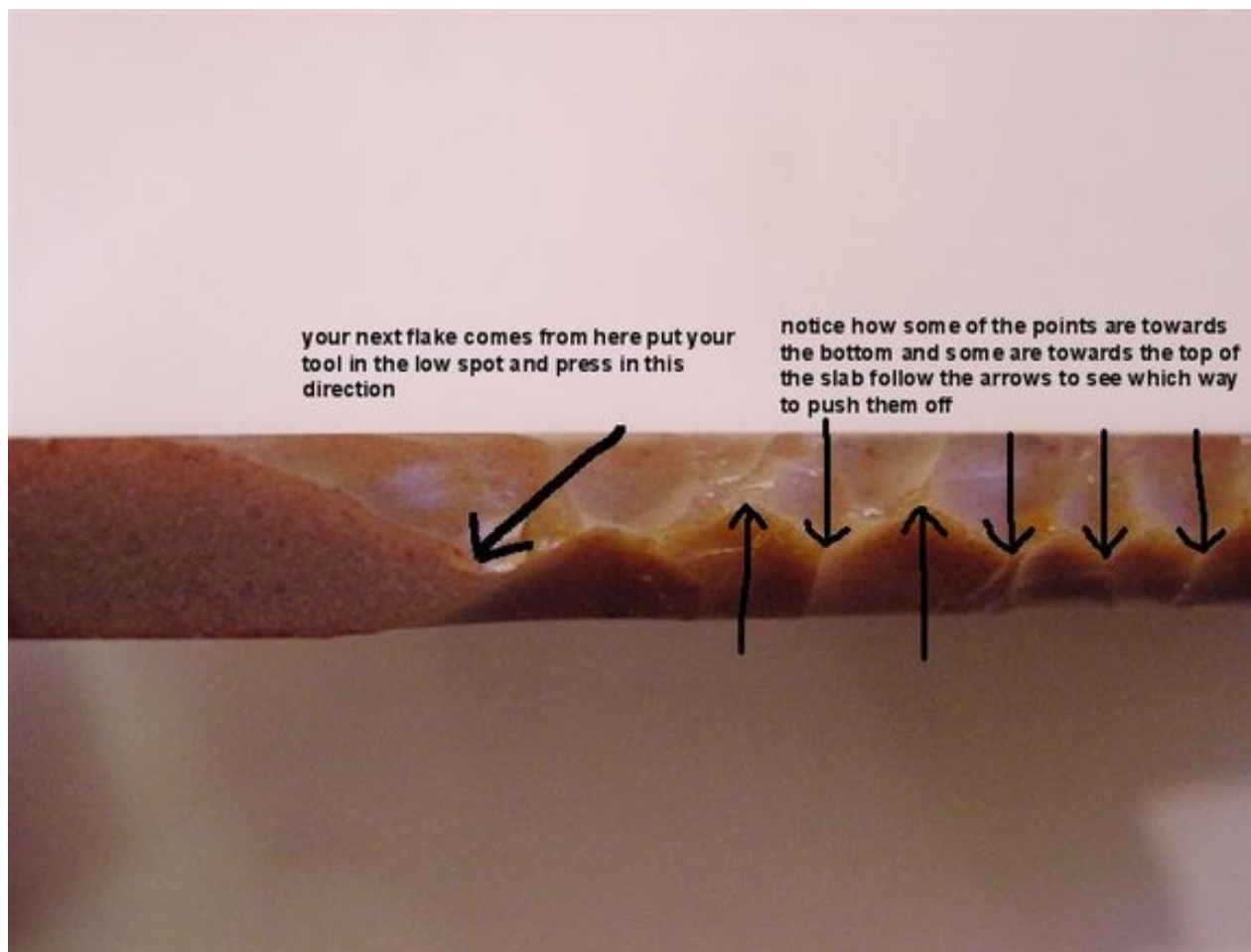

Figure 1



Figure 2

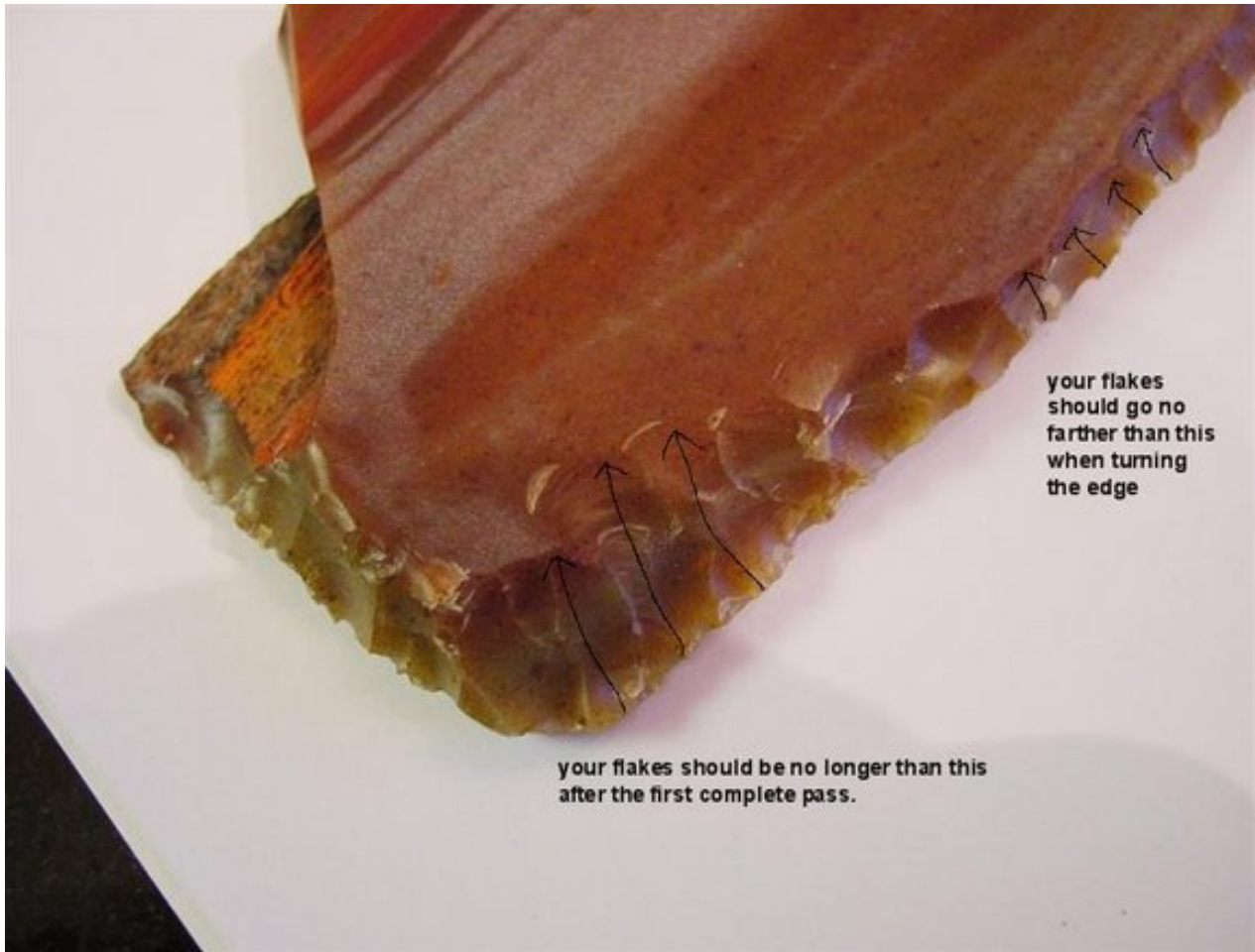

Figure 3





Figure 4



Figure 5



Figure 5a

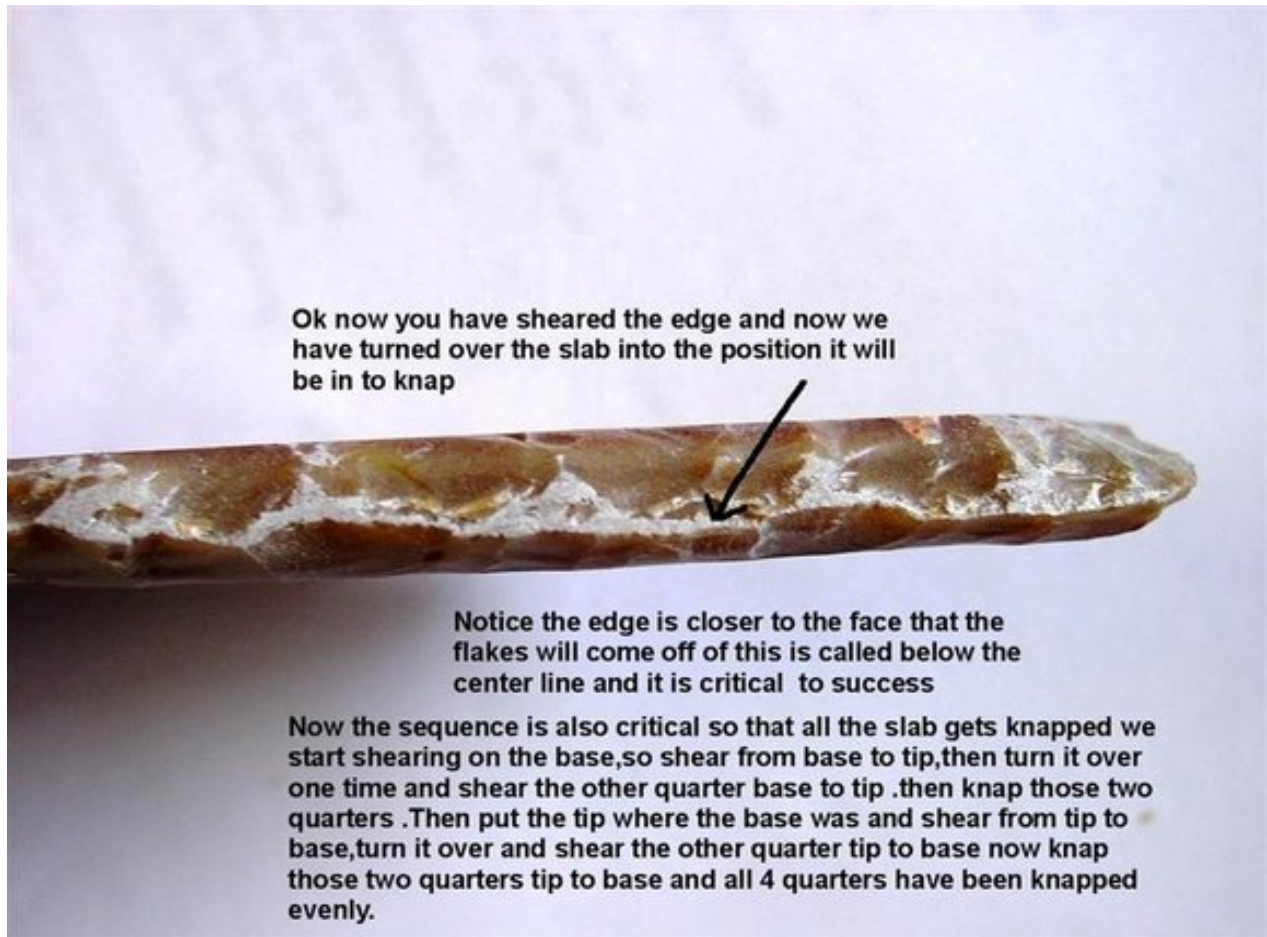

Figure 6



your tool should be sharp how sharp? as sharp as it can be without bending! Notice how i hammered out the tips of my tools i use them as shearing tools too.

Figure 7



Figure 8



Figure 9



Figure 10





Figure 11

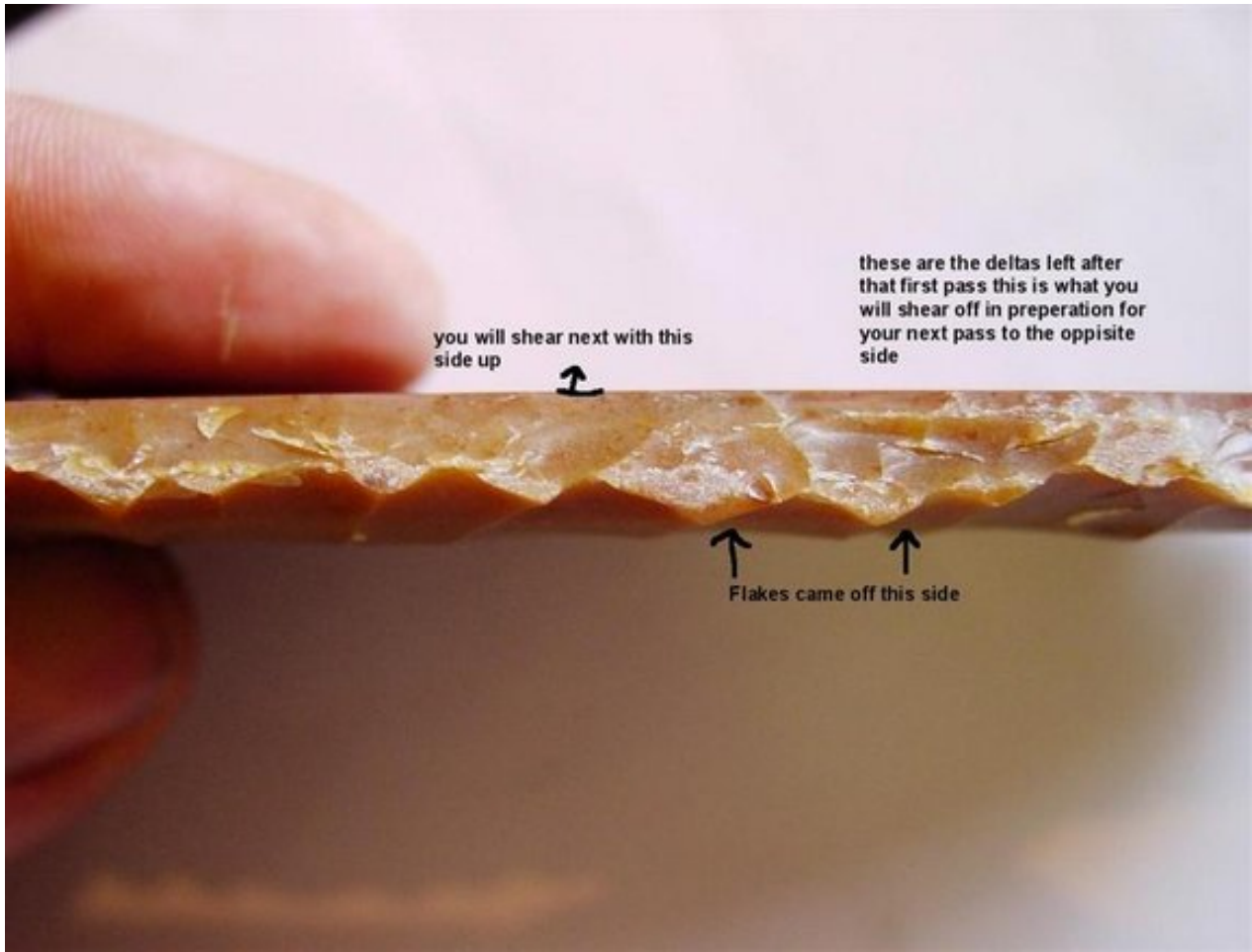

Figure 12



Figure 13"

From <http://www.paleoplanet.net/>, April 3, 2010, copied with permission

# Pressure Flaking a Big Blade from a Slab

By Jim Winn (aka Paleoknapperjim)

The following sequence of pics was taken while knapping a large blade from a slab. The idea is to try to show a successful technique and strategy that can produce a large wide blade using very light percussion and heavy pressure flaking. I did a similar tutorial several years ago, but since that time I have developed a better strategy that is capable of producing wider blades with better success. The following outlines the procedure:

This pic shows the slab before being worked. It measures 15 long and thick. Notice 2 cracks in the lower edge.



P2 I begin by removing the square edge by alternate beveling using a 5/8 thick solid copper billet. Each time a small flake is removed the slab is turned over and another small percussion flake is removed along the edge of the previous flake. This pic shows where I intend to strike to remove the next small flake. Note that the flake to be removed is resting directly and firmly on my leg to dampen the shock to the slab to reduce the chance of breakage. This can be done with pressure flaking also which is less risky but it is very time consuming and tiring. I prefer to just use light percussion.



The square edge has now been removed from the slab. Its rough looking, but the idea here is to just get rid of the square edge so that platforms are created that allow further light percussion to shape the slab. My fingers are pointing to 2 cracks. That edge must be brought in using light percussion until the cracks are gone. Also, only very light percussion can be used next to the cracks or they will run further and possibly break the slab.



The slab now needs to be roughly shaped. Light percussion is used to get the desired shape and symmetry and one side must be chosen to be the first face to get pressure flaked. The goal is to have the edge about 1/8 below the face to be pressure flaked. This picture shows the back face which will be flaked last.



This picture shows the face that we will pressure flake first. Its not perfect, but its good enough! The edge is roughly 1/8 below the face and it has been ground heavily to provide a continuous platform.



I started at the tip and began removing pressure flakes using an Ishi stick. The first 5 flakes do not have to travel far and go nearly to the opposite edge. Now it is time to begin to remove flakes from one edge, then the other. This picture shows the intended flake removal sequence for the next 4 flakes. By removing flakes from one side and then the next, continuous ridges running from edge to edge are created. This allows each flake to travel a bit further. If the flakes are removed down one entire side they will not run as far. That's OK, but if you are trying to maximize the width of the biface it is better to alternate from one edge to the other with each flake. This same strategy works very well with percussion also.



This pic shows the next 4 pressure flakes after they have been removed.



The blade is now flaked to about the midpoint lengthwise. Time to switch to the base and begin removing flakes from the base back toward the midpoint. The advantage of doing this is that it provides an additional opportunity of correcting any short flakes that may happen. For example, if I get a short flake when working from the base toward the mid section I will stop. I then switch back to the mid section and work toward the base and the problem area. It is a lot easier to correct a short flake when doing this. It gives you a second chance to correct the problem by approaching it from the opposite direction.





P9 This pic shows how the Ishi stick is used. Note that the blade is held firmly on a notched rubber pad. My left hand is resting firmly against my left inner leg. My wrist is bent backward so that the Ishi stick force can be applied toward the opposite edge. In reality, the Ishi stick is actually pointing toward the opposite face, in other words, beyond the opposite edge. This is necessary in order to remove as large a flake as possible. Pressure is built up to about the maximum that I am physically able to apply, and then the left hand is rotated very slightly until the Ishi stick is pointing directly at the opposite edge. At that instant the flake will release. This all happens very quickly. It is impulsive. I have seen many knappers building up pressure slowly and straining till they are almost shaking hoping that the flake will release. It usually does not. So they change the angle of applied force till it is pointing toward the face they are flaking. This always results in a short flake. The flake will ALWAYS follow the applied force at the moment it releases.



This pic shows how the blade is supported on the notched pad. Note that the area where the flake is to be removed MUST be directly over the notch in the pad. If the flake touches the pad at any point, that area will result in a small step fracture. The flakes are elliptical in shape, and the notch in the pad must be elliptical in shape also. Pads that are bought are generally straight sided. Dont buy em, make your own! You want an elliptical shaped notch that is sized just a bit larger than the flake to be removed. If it is too large, too much bending stress is created and the blade may break. If it is too small the flake will step at the point of contact with the pad. Trust me on this one!



OK, this pic shows the continuation of the flaking process from base to the mid section. Notice the intended sequence of flake removal, from one edge to the other to provide nice ridges for the flakes to follow.



The first face is now completely pressure flaked. All traces of the saw marks have been removed. However, this face is still fairly flat and lacks convexity. Therefore the plan is to remove another set of pressure flakes from this same face to provide additional convexity and also to provide a better flaking pattern.



The edge is still close to the face just flaked. A small billet is used to drive off small percussion flakes toward this face and move the edge closer to the centerline. The goal is to create a platform very close to the centerline for the next set of pressure flakes, and then to abrade it very well.



This shows the blade after the 2nd set of pressure flakes has been removed from the same face .It is hard to see in the pic, but this face now has much better convexity. In addition, we have lost very little width in doing this.



The blade is now flipped over and the small billet is used to bring the platform up to about 1/8 of this face using very light percussion flaking. The platform is abraded and pressure flakes are removed with the ishi stick starting from the tip to about the mid section again.



Flakes are now removed starting at the base and working toward the mid section, to meet up with the others. As we progress along the length of the blade, longer and longer flakes must be removed. To assist with longer flake travel, I often isolate the platforms by removing a small flake on the other side of the platform area, as seen in the pic. This isolated platform will release with a bit less pressure and travel a bit further. It will result in less bending stress being applied to the blade and will reduced the chance of breakage.



This pic shows the flake after it has been removed from the isolated platform. Right on target!



The 2nd face has now been completely pressure flaked. All saw marks have been removed. The hardest part is now over.



The next step is to selectively go around the blade and remove additional sequences of flakes to thin the edge and provide a good contour from edge to edge. In some area the edge may be very thick and more massive flakes will need to be removed. This pic shows such an area. Notice that I am using a finger guard made from leather to support the opposite edge. This not only protects my finger, but it provides support on the opposite edge. As I apply pressure with the Ishi stick I am applying the force directly into my finger support. This greatly reduces the bending stress being applied to the blade and reduces the chances of breakage. This also encourages the flake to travel further, often from edge to edge. The leather provides protection to the finger.



This is one side of the finished blade. It measures  $14 \frac{5}{8}$  long by  $2 \frac{5}{8}$  wide by  $\frac{3}{8}$  thick.



This is the other side of the finished blade.



This is the edge view of the blade.



These are all the tools used to make this blade.



Hope this can be of use....jim winn

From <http://www.paleoplanet.net/>, April 3, 2010, copied with permission



# Flake Over Grind (FOG) 101

By Tom Dodge (aka peblpmp)

OK....here goes.....others that FOG may use different techniques but this is what works for me.....



Lots to choose from.....I love cutting rock.....especially obsidian.....every one is different.....in fact, every slice is different



Take a slab, orient it the way you want, mark out the shape and trim with a tile saw. Closer trimming here save diamonds later! I slab my own with an 18" Highland Park.



This is the work horse. 10" Poly arbor (very hard to find) with 8" 50 grit wheel and 6" 180 grit wheel.



Grind out the shape then grind both faces into a convex shape. Leaving a median ridge down the middle helps the flakes terminate smoothly. I'm not always successful. Rough it out with the coarse wheel leaving about a 1/16" flat on the edge so you don't rip the edge off. Smooth it out removing all the grind scars with the fine wheel. Start with thicker slabs to allow for grinding removal.



Using the fine wheel, bevel the edge at about 75 to 80 degrees. This edge should be straight with a sharp edge on the side to be flaked. This is your working edge for one face. Measure and mark, if you want to, the evenly spaced flake locations.

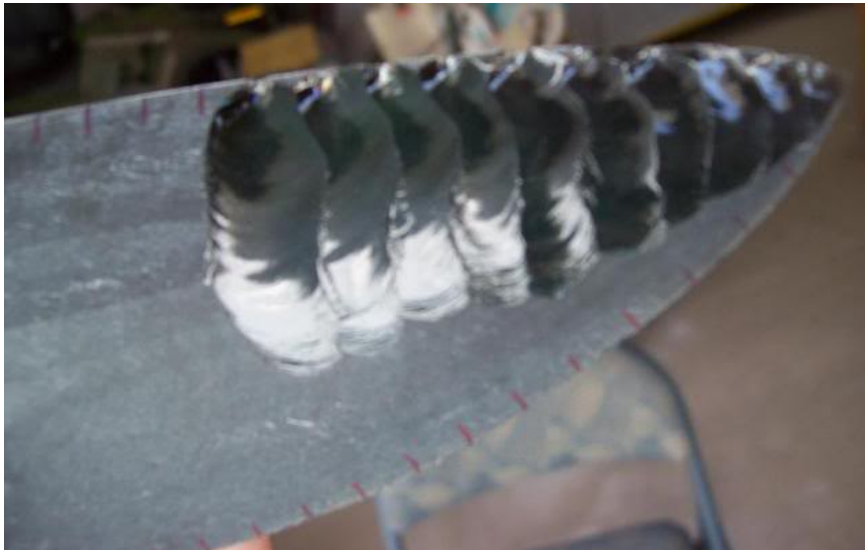

With fine abraider, rough up the working edge and leave the powder on as it helps the copper bite the rock. I use a slotted block and an Ishi stick to flake. Start at one end or the other always flaking into the mass (unflaked portion) side of the previous flake. If you miss a flake or run into other troubles, go to the other end and work back to the booboo; this often helps to better remove "islands" of "frog skin" you missed. Run down one quadrant, then abraid the other edge and run down it.

Remember the centerline rule thingy still applies!!! Try to take every flake exactly the same, ie. same angle, same force, same depth, same everything.



First quadrant.....the thinner and misaligned flake are a result of not doing the same thing every time. It is unforgiving and takes a lot of concentration.



Second quad done.....first side finished.



Back to the grinder (fine wheel) and bevel the working edge back the other way to flake the other face. Repeat above, placing the tip of flaker in the middle (the strongest part) of each delta. No measuring or marking needed as the deltas should be spaced just right.



After all 4 quads are flaked, the edge should look like this.



Back to the grinder (fine wheel) and grind down about 1/16 to 1/8" of the deltas on both sides, leaving a fairly sharp edge for the final retouch.



Retouch the edge, careful to not push in and have the flakes run up the flake scar ridges. Just take off the ground deltas. U B done.....



Other side. Not too bad.

Once again I must thank the omnipresent TwoBears for the rock, which is to die for. There is no way to fully capture the amazing deep metallic glowing color of this Mexican obsidian with photos. I love obsidian.

FOG has been around about 3500 years. They (Egyptians) just didn't have diamond grinders. They did have beer.

Lots of knappers scoff at FOG knapping for various reasons. I personally could care less. It helps to produce what I want to produce.

Hope this is informative for anyone who wanted to know.

---

From <http://paleoplanet69529.yuku.com/topic/23948>, April 1, 2010, copied with permission

# Parallel Flaking Techniques

*by Jim Winn (February 2002)*

Over the years, I have developed some ideas or beliefs on what seems to work when it comes to parallel pressure flaking. I may be wrong in my thinking, and invite other opinions or suggestions or what works from other folks. I am sure lots of folks may disagree with my ideas, but I welcome hearing from them so that we can all learn and improve our skills. Hopefully, maybe some of the following may be of use to others, or at least provide something to think about. Here they are:

1) Parallel flaking can be done straight in or obliquely. Either will work, but oblique flaking is more efficient for several reasons. First, the flake will travel further in an oblique direction than straight in. Why? Because the convexity is less when traveling at an angle across the face than straight in. In other words, it is flatter. All other things being equal, flakes travel further as the face becomes flatter (unless it becomes concave, or course). There is a negative side to this: Flake terminations are more likely to terminate in a step or hinge as the face becomes flatter, but measures can be taken to prevent this

2) Flakes will travel further and are more likely to have a feather termination when absolutely nothing is touching the flake as it is being removed. This is why I use a slotted hand pad, so that the flake area to be removed is resting over the slot. After each flake removal the biface needs to be moved so that the next flake is resting over the slot. If this is not done the flake will often terminate in a small fingernail hinge at the point where it meets the pad.

3) The biface is less likely to break during heavy pressure flaking when the flakes travel obliquely across the face instead of straight in. Why? There is more mass below the flake diagonally across the flake than straight in. Also, the flake is less likely to overshoot the opposite margin because the distance is greater. There is one time when this does not apply, and that is when removing flakes close to the tip when the flakes are traveling back toward the tip. In this case the flakes travel a shorter distance and great care must be taken not to overshoot and break the tip off. I have found that placing the tip of the biface on the pad (not over the slot) works well to prevent tip breakage until several flakes have been removed. Why? 2 reasons. One is that the tip is now supported and less likely to recoil and snap. The second is that the pad is touching the flake and prevents it from traveling as far. It may terminate in a fingernail hinge, but this can be removed when working the other edge, from the tip to the base.



4) Either an Ishi stick or a simple hand flaker can be used to do oblique parallel pressure flaking. But only an Ishi stick can remove massive long pressure flakes. Why? Because tremendous pressure can be applied with the Ishi stick, using not only the arm and leg muscles, but the chest, shoulders and back also. (In fact the whole body can be used with the Ishi stick in the traditional manner between the legs). The closer to the crotch, the more power that can be developed, and in addition the more stable everything is. I find the hand flaker more suitable on the smaller points where great pressure is not required and I am sometimes able to get more accuracy with it. Also, the hand flaker can be twisted at the moment of flake release to increase the travel of the flake. But the Ishi stick is a must on the big knife blades (unless your doing percussion of course).

5) Beginning knappers sometimes have trouble getting the flakes to travel as far as desired. They place all their strength into it and still the flake peters out short. Why? Sometimes it is a matter of strength, but more often I believe the cause is insufficient support of the biface, such that it rotates in the hand. The knapper is pressing with all his/her strength with the pressure flaker while the hand supporting the biface allows the biface to rotate slightly. The pressure now is directed outward instead of straight in, it travels a short distance but not to the middle of the point and the result is a thicker biface. The cure is to concentrate on supporting the hand holding the biface such that it remains absolutely fixed while the pressure flaker is applying pressure. The pressure flaker must apply force nearly straight in for a long flake and not be allowed to tilt outward. Again, supporting the hand close to the crotch and on the inside of the leg provides great support. If the knapper is straining and allows the hand to leave the inside of the leg the hand supporting the biface has to rely on the arm muscles alone for support and arm muscles are simply not strong enough to provide fixed support (unless you have 20" biceps!). Basically, the flake will obey the rules of physics and travel where ever the force is directed.

6) Parallel flaking is more efficient than random flaking (both on percussion and pressure). I am not saying is it right or wrong, just more efficient. Ancient knappers used both methods and of course random flaking is the only appropriate method when duplicating certain point styles. Random flaking must of course be used in the early stages of biface reduction to remove unwanted mass which is randomly located. However, by stage 3 or so, ridges can become established and oriented so that successive flakes can follow the ridge left by the remaining flake.

7) When doing parallel pressure flaking it is not necessary to travel all the way from tip to base or visa versa until the final set of pressure flakes is to be removed. Just continue the flaking sequence where mass needs to be removed. If you hit a low spot, skip past it and start where the next mass needs to be removed. Otherwise the point will be bent or twisted when viewed sideways. This was a problem I had in the early days when I would keep going from tip to base and then wonder why the point was not flat! Even on the final set of flakes it is not necessary to travel continuously if there is a low spot and often skipping over it will not even be noticeable (unless you are doing FOG, in which case there wont by any low spots anyway). Also, when doing a sequence of flakes, try to adjust the length and thickness of each flake to the amount of mass needing to be removed.

8) Longer flakes are wider flakes. Guess this is obvious! But the spacing needs to be increased between flake removals to prevent the flake from diving into the previous flake scar. I still make this mistake when I don't take the time to inspect each flake removal and adjust the next accordingly.

OK, that is all for now. Lets hear from others. Give me some hell! Really, I know there are probably lots of ways to do things better that I have not thought of, and I think that is what this forum is all about, sharing and learning from one another to improve our skills. Perhaps a folder can be created on pressure flaking tips, another on percussion flaking, fluting, etc.

Copyright © 2004 Jim Winn

---

From [http://www.flintknappers.com/oldsite/jim\\_winn\\_parallel\\_flaking.html](http://www.flintknappers.com/oldsite/jim_winn_parallel_flaking.html), April 8, 2010, copied with permission

# Micro Flint-Knapping

by Craig Libuse



## Scaling traditional techniques to extremely small sizes

Dan White (pictured) has been able to create his own form of art, based on what was one of the first forms of art—flint-knapping (shaping stone by breaking off chips). He calls it "micro-knapping". Prehistoric cultures learned early on that flint could be chipped to create sharp edges for knives, arrow and spear tips. The ability to make quality points was critical, as it meant the difference between eating and going hungry. Shape and size varied

widely based on use and culture, but the technique has changed very little in thousands of years. Old points are popular among collectors, and some modern craftsmen have taken to duplicating the ancient techniques, but Dan has taken it to the extreme small end of the size scale.

Over the last few years Dan has made over 100 miniature stone arrowheads. He uses a stereo microscope to reproduce the stone-age technology of flint-knapping in miniature. After months of experimenting, headaches, and stabbing himself in the fingers, he has been able to develop a technique where he can make miniature stone arrowheads the size of a grain of rice that have all the same proportions and flaking as the full-size originals. Each miniature takes between 1 and 2 hours to complete.

## Tools of a new micro-trade

His tool kit consists of a thick rubber pad, a fine grinding stone, various size small nails/pins for use as pressure flakers and Scotch tape. (He must wrap his finger 4 or 5 times with tape to prevent the smaller nails from stabbing him while flaking). He like to use the most colorful stone he can find for his microscopic arrowheads. First, he starts with a flake of stone about the size and thickness of a nickel. He then begins breaking off large chips with a sharp copper nail to shape the stone down into a bi-facially flaked "pre-form". Once the pre-form is complete it's time to use the smaller nails and pins to shape it down and begin finishing the edgework and notching or fluting. Notching is done with a small nail that has been flattened and sharpened. He makes all the pressure flaking tools with the help of a microscope. Micro-knapping is basically the same as normal flint-knapping in the way each flake has to be removed in a very similar and precise manner.



*Seen here are some of Dan's favorite micro points, described from left to right: 1- A T-drill style point made of Kaolin flint from Oklahoma. 2- Another T-drill style made of opal from Australia. 3- His smallest point- a paleo style fluted point made from Alibates chert from Texas. 4- An arrowhead made from striped opal from Australia. 5- A Dalton-style made from Kaolin from Oklahoma. 6- A "bolen bevel" style point made from quartz crystal from Maryland. 7- A stemmed point made from Brazilian agate.*

### **Scarcity of materials leads to miniature craft**

Dan has been a collector for most of his life and his interest in ancient stone arrowheads is what eventually led to his pursuit of flint-knapping. When he first started trying to make arrowheads he had no way to get large pieces of flint to practice with, so he decided to make miniature arrowheads using tiny pieces of stone that had broken off some damaged arrowheads in his collection. As far as he knows, he is the first person to ever try flint-knapping under a microscope. Since he had never heard of this before, there was no place to go for guidelines or advice.

It took several months to develop his technique and figure out the right tools to make. After much practice and pain, he was able to make a miniature arrowhead under 2 mm long that has sharp edges and is flaked on both sides just like the full-size ones. His smallest arrowhead was considered for the *Guinness Book of World Records*, but because there is no category for arrowheads or flint-knapping (and they didn't feel like creating one) he was turned down. However, some of Dan's work is in the Smithsonian collection and his smallest piece has been photographed by the Smithsonian's photographer. He has sold some individual miniatures to collectors in the past but would rather keep most of them and enjoy them himself, especially since they are so difficult to make.

### **Early difficulties solved by better tools and techniques**

When Dan first started, his only tools were the microscope, a pin for the notching, a pocket knife and some card paper. He would find the thinnest, flattest chip of stone and then shape the edges down with the tip of the knife blade while holding the stone between his fingers in a piece of card paper. The first 10 or 15 were crude looking and not bifacially flaked (flaked equally on both sides). He used the pocket knife for a while before realizing he could never get the results he wanted (bifacial flaking) with such a hard chipping tool. This is when he started using nails and placing the stone on a rubber pad to get longer pressure flakes.



*One of Dan's arrowheads is shown here attached to a miniature arrow.*

When starting out and trying to teach himself how to make these tiny points, Dan would break two or three for every one he finished. After finally getting the tools and technique just right, he says he can now make two or three (if he's really careful) before he breaks one. According to Dan, "The hardest part is doing the notching and the flute flakes for the Clovis style points. Naturally, most of the breaks happen after much of the work is already finished. If I can get the arrowheads to look good under the microscope, they will look really good to the naked eye, but sometimes I break them on purpose if they don't look just right."

Dan admits that he has dropped a few of them and lost them in his carpet including a couple of his best ones. After spending over an hour looking for one he has to give up in frustration. Even so, he says working this small is worth it.

### Here are several examples of Dan White's work:



ool kit includes:

eo microscope (it's a lot harder to make arrowheads without it but it can be done). ssure flaker with a sharp copper nail for the pre-forms, and some smaller pins ls for the finer chipping work. Also some clear tape used to protect his finger ing poked by the nails while pressure

ill grinding stone used to grind the edge re-form prior to chipping

ber pad cut from a tire for placing the 1 while chipping. On the pad is a red f stone typical of the size and shape he start with.

ny is to show size. The small hafted 1 the center has a turtle bone handle with ew keeping the blade on.



arrowhead samples of various shapes are next to the tip of a toothpick for size ce.



Small points, all of a similar style are next to a penny.



Dan's smallest arrowhead, a fluted and finely flaked Clovis-style point that measures just over 1 mm. According to geologist Dr. Dennis Stanford at the Smithsonian and the people at Guinness Book of World Records, this is the smallest knapped arrowhead they have ever heard of. This is the only one he has made this small and says he doesn't think he wants to try it again. He made it many years ago and had to hold it down on his finger using a popsicle stick while flaking it with a tool he made just for this point. It took about 1-1/2 hours to finish.



All points are all made from Alibates flint by Dan's late friend George Chapman near the Flint Quarries National Monument, the ancient flint quarry in the Texas Panhandle. George lived near the quarry and he would send Dan a pile of small flakes he picked up in exchange for a finished point or two. Dan considers this some of his favorite material to work with.



These are some of the first ones Dan made from pieces of arrowheads. All are made from Alibates flint and are only chipped on the edges.



These three glowing "opals" are all made from Mexican Opal from Lightning Ridge.



This is the only one picture of himself at work with a microscope. It was taken by Val Waldorf in 2002 at Flint Ridge, Ohio for the 2002 *Chips* publication for flintknappers. (Vol.14, #4)



Dan also created other weapon shapes as well, from spear points to daggers. The handles were made out of tiny bones found in owl droppings.

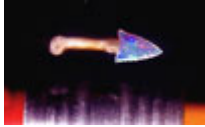

with an arrowhead-like point made from  
flint.



stone knife of the type chipped from  
flint.

---

From <http://www.craftsmanshipmuseum.com/White.htm>, April 7, 2010, copied with permission



## Section 5: Fluting & Notching



# Fluting Instructions

by Gary Merlie

This series of pics are a composite of work on 2 different preforms. After each of the flake removals in the first few pics, remember to clean up the little overhangs just like you do when making a biface. There are many critical variables that I could not cover in these few pics. Nipple grinding, cross section of preform, and placement of the lever just to name a few. You will just have to experiment. All of the knapping/fluting was done with copper and modern tools. Fluting abo style is a whole different ball game, a game I have never played. I would love to see a similar layout like this one dedicated to abo style fluting by one of the good abo knappers like Bob Patten. (hint hint) Rockhead

Bevel base toward side to be fluted.



Remove flakes 1 & 2 on the side to be fluted to define nipple. Remove flakes 3 & 4. These are guide flakes to help flute flare out correctly.



Turn point over and remove flakes 5 & 6. These removals isolate nipple.



Remove flakes 7 & 8 from side to be fluted. These removals act as guides, and further isolate nipple.



Turn point over and remove flakes 9 & 10 as needed. These removals regulate the width of the nipple. Remember when making nipples: Define, isolate, regulate, and grind.



This nipple is ground and prepared for fluting. The guide flakes could be better, but it is good material from Harrison Co. Ind. and the flute will probably go.



View of overall preform. Note how nipple is isolated and out towards face to be fluted. Ears are back away from face to be fluted. I grind the ears at this point to keep them from snapping during fluting.



Preform in jig ready to be fluted. Note tip of copper lever on top of nipple. Side to be fluted is facing jig.



Copper lever. This tool has 4 working faces so you don't have to dress it as much.



Close up of copper lever on nipple. Ready to flute.



Preform and flute spall immediately after fluting. This flute ran about 4".



Here's the finished point after the other side was fluted and much pressure flaking was done to give it the distinctive Cumberland fishtail shape. Length is 4 1/2". I rubbed a little mineral oil on it to give it the nice glossy look. Total time to make this point? A lot less than it took to edit and post all these pics!



Copyright © 2000 - Gary L Merlie - All Rights Reserved.

---

From <http://www.ssrsi.org/Onsite/fluting.htm>, March 31, 2010, copied with permission

## Hand Fluting

By Bob Patten (aka knapperbob)



I picked a tough piece of raw Utah agate to make a Folsom. The weathered surface is deceiving.



You can see that the stone tears rather than breaking smoothly, but works well otherwise. The unweathered interior looks quite different from the weathered outside.



I used antler baton percussion until the thickness was even and relatively thin. Some length was lost due to careless work.



After the surface was selectively contoured by antler pressure, I gave the base a bevel.



A little more work and the platform is isolated. I set up a 2 mm gap between the platform and a straight edge to control flute thickness. At this time, I make sure that there are no gaps between the straight edge and the preform crest.



The first platform is ready for fluting.



You can see my view of the fluting anvil, a moose billet resting on top of my calf muscle.



Here, the preform is in place atop the anvil. The blow follows through to land on a heavy leather pad near to the action I normally use while doing regular percussion. My avatar demonstrates the approximate positioning for fluting.



Backlighting shows the translucent nature of this agate.



Unfortunately, I held the preform off center and the first flute peeled to one side.





With just a small adjustment, I have a new platform near the edge of the preform base. Ready for another try in under a minute.



As we say, "the operation was a success, but the patient died." Although the flute went full length, an unfortunately-placed crystal pocket caused the point to snap. With a few thousand years of weathering, this point could have taken on the relatively smooth appearance of the starting quarry blank.

---

From <http://paleoplanet69529.yuku.com/reply/126388#reply-126388>, April 4, 2010, copied with permission

# Folsom Workshop Fluting Experiments

by Tony Baker

In the afternoons of the Workshop we would adjourn to the loading dock of the Texas Archaeological Research Laboratory and the knappers would demonstrate their methods of fluting a Folsom point. All the knappers can make the preform from which the channel flakes are removed. It is the removal of the two channel flakes that are the most difficult steps of Folsom point manufacture. Most of the knappers brought some prepared preforms ready to be fluted (channel flakes removed), so the first day there were many fluting demonstrations. After the pre-workshop preforms were exhausted, then the knappers would spend an hour or so making a new preform and then the fluting demonstration would take only a few minutes. So the pace of the afternoons could be described as mostly slow and relaxing with an occasional burst of excitement.

Those of us who could knap were involved in these activities and the rest watched with envy. Besides making Folsom points, the group made Clovis points, ultra-thin bifaces and mesoamerican blades. These were some of the activities that were captured on film by Dick Boisvert. Thanks Dick.

## Assisted Indirect Percussion -- Bob Patten



The tools Bob used are visible in this image. They can be used for both assisted and unassisted indirect percussion. The tools consist of a large block of wood with two pegs, a bone tipped punch (immediately above the block of wood), a second punch (the straight stick lying on top of the block), a large rock for the hammer, and the strap of leather (for unassisted fluting). This image also shows some of the fluted preforms from the day's

efforts.

In this image, Bob is performing unassisted fluting. The leather strap has been used to fix the preform against the two pegs. The bone-tipped punch is placed on the platform and its other end is held between Bob's knees. The straight punch is then placed on top of the bone tip punch and this is hit with the hammer. Bob says he really doesn't hit the straight punch with the hammer. He just lets the hammer fall under its own weight. If the technique was assisted, a second individual would hold the preform against the pegs, and the leather strap would not be used.



This image captures Bob at the instant the channel flake was removed. Notice the bone punch is now on the block of wood.



This is his preform prior to fluting ...  
and this is the preform after fluting.



### Direct Percussion -- Phil Geib



Phil's technique of fluting a Folsom point was one of the simplest methods used at the workshop. His tool kit for fluting consisted of a hammer-stone and a rock anvil.

Phil would hold the preform and anvil in his left hand. The anvil was pressed against a large massive surface and the preform held horizontally and against the anvil. He would then strike the channel flake platform with the hammer-stone, held in his right hand.



This is the result of the effort in the previous image. Although the channel flake hinged through the preform at the distal end, there was still enough fluted preform to build a Folsom point.



## Direct, Freehand Pressure -- Eugene Gryba



Gene's technique of fluting is even simpler than that of Phil's. He just uses pressure. In this image he is creating his preform.

In this image he is actually fluting. You can see the strain in his face as he applies the pressure to remove the channel flake. One would think Gene had hands of steel.



However, they are only skin and bone. See the callus that Gene developed over the couple weeks of practicing prior to the workshop.

This is Gene's tool kit; very simple, small antler tools.



## Indirect Percussion with Vise -- Gene Titmus



Gene's technique is very similar to Bob Patten's. Here the preform is held in a vise instead of being fixed with a leather strap. However, Gene delivers his blow directly to the punch in contrast to the double punch arrangement of Bob. The piece of railroad tie is to add mass to his assembly. In the image, Gene is using a copper pointed punch. He also demonstrated the technique with a walrus ivory punch. Gene's results.



## Indirect Pressure with Rest -- Kenneth Rozen



Ken's technique requires the preform to stand (rest) vertical with the distal end on a hard surface (rock). Ken creates this condition by digging a small hole in the ground and placing a flat sandstone rock in the bottom. Two flat rocks cover part of the hole and touch in a manner as to create a corner of 90+ degrees. This is an image of the assembly.

With the preform resting in the corner of the two rocks, the channel flake is removed with pressure applied by a long antler tool. This is an image of John Clark aligning the tool in preparation for removal of the channel flake. Unfortunately, the image of Ken performing this act was too dark to display so this one of John trying the technique was used. Apologies to Ken.



This is an example of the results of Ken's technique.

## Levered Pressure with Rest -- Dennis Stanford



an atlatl. This image shows a preform resting in a slot that is too long for the preform.

This image shows a spacer added to the slot so the preform is correctly positioned.



This image shows Dennis removing the channel flake. This was done by applying pressure to the platform with a narrow antler inserted through a hole in the atlatl. With this lever arrangement, Dennis was able to generate the necessary force.

This is the result of his attempt. The preform in this experiment was made by Bob Patten.



---

From <http://www.ele.net/workshop/images.htm>, September 24, 2010, copied with permission

# MAKING FLUTED POINTS WITH THE SOLLBERGER JIG

by Woody Blackwell

Photographs courtesy of Dave Rauschenberg



Side 1



Side 2

Fluted points are one of the highlights of lithic technology. We all know that they date to the earliest known occupation of the Americas, but for a variety of reasons, the reproduction of fluted points ended about 8,000 years ago. That is, until a few master craftsmen such as Don Crabtree and J.B. Sollberger began to attempt replications several decades ago.

Now there are almost as many fluting techniques as there are modern knappers, but one of the earliest methods is arguably the most successful. Working almost entirely on his own, J.B. Sollberger spent many years perfecting the three components of his technique: the preform, the platform, and the jig. (From here on, I'll refer to 'him as J.B.: -due to my mediocre-typing-skills and not a lack of respect for this quiet genius).

Besides being one of the best knappers of our time, J.B. is also extremely generous in sharing his discoveries. This article and the one to follow, is based squarely on the techniques he developed and then taught to a new generation of knappers. I was very fortunate to have been one of them.

Now that credit has been given where credit is due, let me say that I'm better at showing than at explaining. If this article confuses the daylight out of you, grab me at a knap-in and I'll be glad to try to clear things up. The Waldorfs also have a video available which has a section on J.B.'s fluting technique, which is also called the "Sollberger Jig".

The first thing to tackle is the preform. This is a three dimensional challenge. Although there is considerable variety in the size and silhouette of Clovis points made with J.B.'s technique, they all share some common traits in the preform stage. Those traits deal with the cross-section and contours, which we'll cover now.

First off, make the preform as smooth as possible.

Good contours are absolutely essential to long, successful flutes, so examine the preform closely both lengthwise and widthwise. The median ridge's contour from base to tip should be gently convex. The same goes for the side to side contours. Basically, the preform should be bi-convex with a cross-section in the ballpark of Fig. 1.



If you want a flute that goes to the tip, keep that cross-section from one end to the other. Preforms, with flattened cross-sections usually fail: the flutes run wide and cut through to the other side (this is not good).





FIG 2.

Overly steep cross-sections (see Fig. 2) often result in shallow, narrow "skimming" flutes (and you can do better than that -- remember, the whole purpose of fluting is to thin the hafting area). Also, if a long flute is your goal, the thickest part of the preform should be about 1/3 of the way between the base and the tip as shown in Fig. 3. One strong warning: don't create a "steep climb" between the base and the thick section: as I learned the hard way (with about 125 consecutive broken preforms), if the climb is too accentuated, the flute will dive, resulting in a cloven Clovis (properly known as a reverse hinge fracture). This is a good way to examine the lengthwise contour: place something long and straight (like your Ishi stick) on the preform's median ridge and then look at the preform from the edge. The high spot (where your Ishi stick contacts the preform) should be 1/16th to 1/8th inch higher than the basal edge. Generally, longer preforms need greater height differences, but differences greater than 3/16" are bad juju .. ,

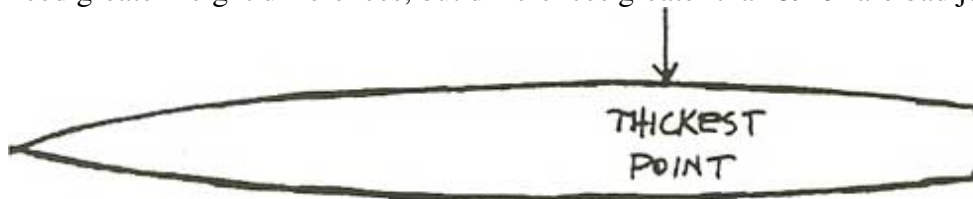

FIG 3

Also, that high spot should be between 3/4" and 1 & 3/4" from the basal edge, depending on the length of the preform. One of J.B.'s rules of thumb was that the high point ought to be about 1/3 of the way back from the base to the tip for very long flutes.

Lengthwise, both high spots and low spots can cause a flute flake to stop (see Fig. 4 & 5). If that's your intention, great; you can use high and low spots to control flute length, but your flutes will terminate differently. A flute stopped- by-a-high- spot-will- result- in- a-hinge fracture. A flute that ends in a low spot will typically "feather out" . Personally, I prefer a steep hinge, similar to the points from the Lamb and Vail sites.

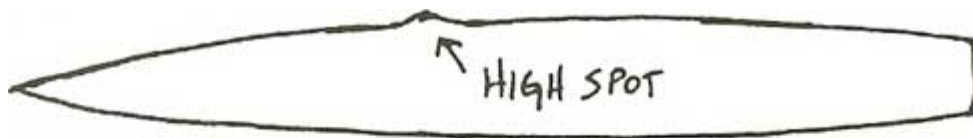

FIG 4

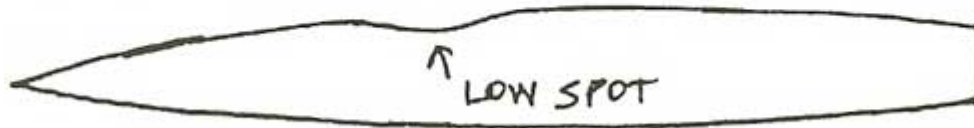

FIG 5

If it's a long flute you're after, don't try to "blow through" a high spot. You're likely to get a much shorter Clovis when the flute dives through, cutting your preform in half. If you can't lower the high spot with pressure flaking, try grinding the high spot down with a fine abrader.

Don't try to flute into a concavity that occurs in the first inch or so of the preform. I speak from experience: it will be a disaster. One of several things may happen, all of them bad. If the preform survives, you will have a Clovis with an extremely short flute. At worst, you'll have a two piece Clovis. I recommend extensive "remodeling" of that preform face to build proper contours. A few more minutes of pressure flaking may save a couple of hours' work. But more importantly, it may save that nice piece of stone.

To develop the side to side contours, I run at least two passes of pressure flaking on each face after all percussion work is done. Deep gouges and high spots behind hinges will result in flute scars that "wander" as in Fig. 6. A smooth preform will give you a flute scar with relatively straight sides. By J.B.'s exacting standards, the straighter the better, as that indicates finer workmanship. (There is another factor which can affect flute scars which will be covered in another article).



FIG 6

At this point, you should have a preform that is close to the final silhouette you're after. Clean up any remnants of pressure flaking platforms that might be left on the edges, double check the contours, take another bite of the cheeseburger you bought two hours ago, and get ready to build the fluting platform.

The first step in making the platform is to pressure flake a 45 degree bevel across the base (Fig. 7). This might take several passes. Flake away from the face you intend to flute. After grinding lightly, drive pressure flakes on the face you want to flute from the basal edge toward the tip of the preform. Do not flake down the median ridge: leave that part of the basal edge alone. That's the area you're trying to isolate: it will become the platform, also called the "nipple". Take short flakes near the preform's basal, corners, as that area is thin and fragile. As you approach the midline, you can get aggressive and remove a lot of material (Fig. 8). If you need to, regrind the two sections of the basal edge and take more pressure flakes. Basically, you're now beveling in the opposite direction. The goal is to leave the median ridge/nipple intact and "high and dry" - meaning well isolated from surrounding material.

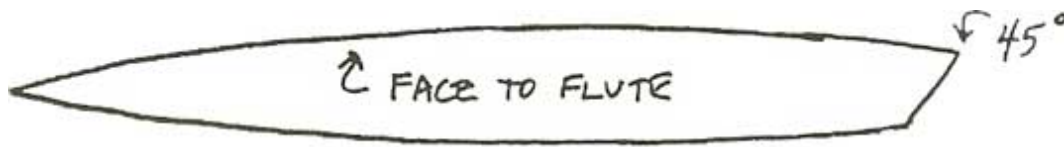

FIG 7



FIG 8

Now for the little part of the basal edge you left intact. It should be between 1/8" and 3/16" wide (Fig. 9). With a sharply pointed pressure flaker, gently "square up" the area around the nipple (Fig. 10). With the same sharp pressure flaker, you need to take at least two flakes off the back side of the nipple (the side you're not trying to take the flute off of right now). Start the flakes at the "corners" where the back of the nipple joins the preform. Run the flakes toward each other, it may take several flakes and some delicate "nibbling" to properly relieve the platform. Clear as mud? See Fig. 11, which might be easier to understand. These important little flakes relieve the back side of the platform and should reduce the thickness of the platform by roughly half. Because it's impossible to make identical platforms every time, generally, a wide platform should be thin; conversely, a narrow platform should be thick. The quality of the material is a player here, as very "tender" material requires a stouter platform. Obsidian, for example, requires some of the heaviest platforms, meaning both wide and thick. Determining the optimum platform size is a skill that will come with practice. Keep in mind that the object is to build a platform that will absorb/store a great deal of energy (pressure) and then release "cleanly" (meaning the right place at the right time), allowing the flute to travel down the preform at the proper depth and speed.

Now with the finest grinder you can get your hands on, you need to grind a flat top on the end of the nipple. The flat spot should be roughly at a 90 degree angle to the centerline of the preform. You also need to grind a flat spot on the opposite end -the pointy end that mastodons worried about. And then lightly grind the edges of the preform in the hafting area. In the next article, I'll tell' you what all this grinding is about. I'll also describe the Sollberger Jig. Although my friend (and fellow fluter) Joe Miller might tell you that the Sollberger Jig is a traditional Swedish folk dance, it's what you need to flute the preform you just learned to make. After you have made your first good Clovis though, I guarantee you'll definitely feel like dancing.

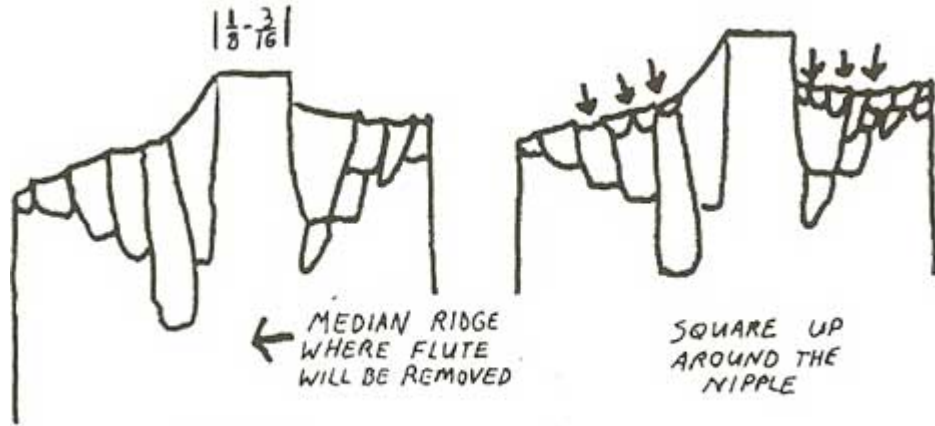

FIG 9

FIG 10

REMOVE "RELIEF" FLAKES FROM BACK SIDE OF NIPPLE SO IT LOOKS LIKE THIS

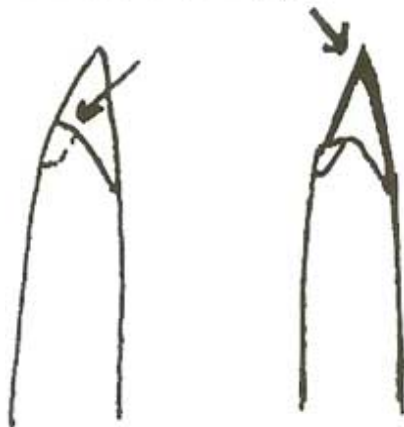

FIG 11

GRIND A FLAT SPOT ON THE NIPPLE



FIG 12

## THE SOLLBERGER JIG

"D.C., there's only one thing from your drawings for Part One (Chips Vol. 6 #2) that I suggest changing. The back of the platform needs to be "released" a little more than as drawn. The flakes that are removed from the bottom corners of the nipple need to meet behind the nipple, or better yet, overlap." -Woody Blackwell.

In April, a vague article on the Sollberger Jig appeared in Chips, Vol. 6. #2, (Blackwell:6-7). Let's say you spent an hour or two trying to make sense of it. Now let's assume you are still interested and want to build a jig of your own. Boy, are you a glutton for punishment, but don't let me try to talk you out of it. Read on.

In the first article, we looked at the preform. In this one we'll take a quick look at the jig. Let me stress this up front: although there are fairly close guidelines-to follow to build a good preform, jigs can be virtually any size or shape. The jig's purpose in life is pretty simple: to hold the preform steady while pressure is applied to the platform; with such a broad purpose, there's plenty of room for innovation and creativity. If you want to simply copy the drawings, that's fine, but I encourage you to experiment: improve on the design, use different materials, or be even more creative --I've thought about making a jig which looks like a mastodon, in which the preform would be held in the tips of the tusks.

J.B. Sollberger is the Einstein of the jig. I don't know how many spectacular points he has fluted (and he may not know either) but it's undoubtedly in the multi-thousands. His jig looks like the product of an inspired tinkerer (which it is). It's made of whatever he had laying around his garage: there's tongue and groove oak flooring, sections of broomsticks, twine, hose clamps, 'C' clamps, a copper pipe, and good intentions. My point is, the tool doesn't need to match the product, technique is what J.B. taught, and hopefully, I can get a little of it across too.

In order to get us all using the same vocabulary, here's a diagram of my jig. There's nothing magic about the dimensions -- it just happens to fit me pretty well. If you happen to enjoy food and have a lifetime accumulation of apple pies, mashed potatoes, and chicken fried steaks spread around your mid-section, you might want to make the jig a little longer so you can see the end (my wife suggested that I make mine a couple of inches longer and add a tractor seat. What a funny girl!).

Use a good hardwood to build the jig. I've used cherry, maple, white oak and ash and all worked well. Joe Miller has a gorgeous jig made out of cocobolo, a brilliantly colored exotic wood from Central America. Mike Peterson of Laramie, Wyoming has an industrial strength jig made from inch thick machined aluminum. I think the only guideline is that you should avoid soft materials that flex too much or get dented easily. Also, I've used wood that was about an inch thick, although 3/4" wood would work just as well.

The tip support should be made of a material that is solid and able to take a lot of pressure, but not so hard that it breaks the tip off the preform. I use a small piece of antler from a moose palm. I've also seen some made of dense plastic and aluminum, but antler is my personal choice. My bit is made of 1/8" copper sheeting which I bought from a metal supply house. A retired

machinist cut it and drilled the holes for me, although it's possible to cut it with a hacksaw. J.B.'s bit was made from a copper pipe which he slit lengthwise with a hacksaw and hammered flat. He also had a second bit with an antler tip on it, which was held in place with hose clamps. J.B. felt that his success rate with Folsoms was much greater when he used the antler tipped bit.

The lever can be of most any material, but I use wood that matches the rest of my jig. You need to drill a hole through the narrow sides of the lever. Center this hole: the hole may split out when pressure is applied if the hole is too far to one face. You also need to put a slot in the same area, except the slot goes through the wide faces of the lever, (see drawing). The copper bit will go through the slot and a galvanized nail is the fulcrum for the lever, it's important that you use a nail that won't bend. That's why I recommend a galvanized nail, which you can buy at virtually any hardware store.

You should also cut a shallow "shelf" on the lever in this same area. It's not essential, but the end of the shelf serves as a stop, keeping the lever from sliding under the baseboard.

Glue soft leather into grooves near the end of the clamp arms. The leather is there to provide a soft but firm grip on the preform as it's fluted. The leather I use is about 1/8" thick and has a suede-like texture. The leather alone won't hold the preform securely during the fluting process, so use some kind of clamping or tightening device. J. B. puts a C-clamp behind the leather. I have a threaded bolt that goes through both the clamp arms; a wing nut tightens them around the preform. Don't go overboard with the tightening. Just get it finger tight and then snug it up a touch more. If the preform is held too tightly, the extra pressure may snap the corners off the preform.

My riser has a lot of holes drilled in it to accommodate preforms of varying lengths. The trick here is to keep the preform at a 90 degree angle to the baseboard. Place the preform in the clamp arms and try various positions in the riser until the preform looks like its closer to 90 degrees. You can make the risers any size you want, just so they're slightly taller than the largest point you think you'll want to flute. The point here is that one jig can be used for all sizes of fluted points --Folsoms to Cumberlands to Wenatchee-size Clovis.

Now we're ready to hit the "on" switch and fire the thing up. You clamped the preform securely in the arms after you ground the basal edges lightly and ground the tip. The preform is at a 90 degree angle to the baseboard. The lever's shelf goes under the baseboard and the copper bit goes on the nipple. Being the consummate craftsman, you carefully ground a flat spot on the nipple and now you make sure the bit sits flat on the nipple -- if it doesn't, you file the bit to match the nipple.

Looking from the side of the jig, place the copper bit at about a 10 to 14 degree angle to the preform (it varies according to preform length -- the longer the preform, the lower the angle). And incline the lever a little, as it will be easier to push down. Put the whole contraption on something solid, sturdy and flat. Climb on and get "comfy", keeping in mind it's not your favorite recliner. Lean over the preform and make sure the copper bit and lever are centered on the preform. If they're off to one side, the flute will probably run that way too.

Now comes the finesse, lightly hold the top of the bit in one hand and put gentle downward pressure on the far end with the other hand. While holding the bit in place, gradually build up downward pressure with the lever. Once there's enough lever pressure to keep the bit in place, begin to apply very slight outward pressure on the bit -- just enough pressure to make the copper bit clear the preform when the nipple releases.

How much downward pressure should you use? That's a hard one. You'll have to discover that for yourself, as the answer depends on the material, the way you built the nipple and the length of the lever. I feel I have too much pressure when my lever-arm starts to shake. Joe Miller says the pressure is too high when he bends the lever like a rainbow. Mike Peterson, with his federally-licensed atom smasher, can reduce a nice piece of Pedernales flint into neutrons and protons. With experience, you'll find the upper range that's right for you.

Just be prepared for the frustration of a learning curve.

You'll break a few nice preforms. Maybe even a lot of them. Once you've completed a few killer points though, you'll be hooked. I strongly recommend that you learn with a material that's readily available and inexpensive, like obsidian. Obsidian, being a little unforgiving, will also force you to learn good knapping skills, such as control and accuracy. And don't believe the Paleo Indians didn't use it -- there are thousands of obsidian fluted points and even entire sites filled with almost nothing but obsidian.

Just do yourself a favor. Until your fluting skills catch up to your fervor, hide the Flint Ridge, the Knife River, Crescent and root beer chert. Give yourself at least a year to get a good grip on this technique and then go for it.

Now, let's look at some of the common problems, and what might be causing them, and what you can do to cure them.

## **PROBLEM SOLVING**

I hope that some of you have built your own versions of the Sollberger Jig and have started to make fluted points. If you're working alone without the expert guidance of a master knapper like J.B., you may have encountered any of a number of different problems. While I don't pretend to know the solutions to all the problems involved in fluting, in this article I'll try to discuss some of the more common problems and what may have caused them.

One corner of the basal edge broke off. This is a pretty common one for me. Several things could be the cause: first, check the clamp arm. The slots which hold the leather pads should be exactly opposite each other and parallel. If they aren't, they could torque the preform as clamping pressure is applied. If the clamp arms look okay, check your preform: are the ground edges nice and straight? If not, the result is uneven clamp pressure. A third possible explanation is that you used too much outward pull on the copper bit: make sure you aren't pushing outward too hard with your hand that's holding the top of the copper bit. And if you're making a Folsom, the preform may have been too thin: you might have exceeded the tolerances of the material.

Deep undulations in the flute channel. Well, at least it fluted. Dig around in the dÃ©bitage pile and find the nipple. I'll bet dollars to doughnuts it's awfully stout. You probably had to use a lot of pressure, both downward and outward, to get the nipple to release. And when it turned loose, it came off with a bang. Build the nipple a little lighter next time. Make sure it's well-isolated on the backside. And on the face to be fluted, try to run some good relief flakes parallel to the center line.

The flute dove and cut the preform in two within the first couple of inches. This is what you almost got instead of the deep undulations. Again, the platform may have been too stout. Also, the arc of the lengthwise contour may have been too great. Don't ask the flute to climb a sharp incline: it will take the path of least resistance -- straight through to the other side.

The preform split or cracked lengthwise. It sounds like the platform didn't release. Was it too stout? And did you have an angle of 12 to 15 degrees between the copper bit and the preform? If you used a smaller angle, there may not have been enough out pull to cause the platform to release; because there was a lot of pressure being applied, something had to give.

The preform fluted the wrong way, from the tip towards the base. This is an easy one. Assuming you ground the tip well before you tried to flute the preform, there could be a couple of reasons for the accident. First, the tip may have moved during fluting; sometimes that will drive off short flakes. If you've used the jig a few times, check the tip support: it may have some small flakes stuck in it, especially if it's made of antler. Anything hard that's trapped between the point and the tip support may-cause flaking.

The preform fluted, but the flute was too wide. Probably due to one of two things (or maybe even both): either the preform's cross-section was too flat or the platform was too stout. Find the channel flake and see if you can determine the cause.

No flute and the nipple is gone. Sounds like the nipple crushed when you applied pressure with the copper bit. It could be that the nipple was too small for that material. Or maybe you forgot to grind a flat spot on the nipple where the copper bit contacts the nipple. Re-bevel the preform's basal edge, build a new nipple and try again.

Short, shallow flute. I suspect the platform released too quickly: a clear case of premature eflutulation. If the flute just barely skimmed the median ridge, there was probably no harm done. Just build a new nipple and try again. If, however, the flute was a little deeper and really degraded the side to side contour, you can re-flake that face to get a good contour and try again. But make sure that the copper bit sits flat on the nipple's ground spot: if the copper only contacts an edge of the nipple, small flakes will be driven off, or the nipple may crush.

Edge of the' flute channel wanders, but deep undulations are not present. The preform may not have been very "smooth". There may have been some high or low spots along the edges. Keep trying to make the cleanest possible preforms, which will lead to straight-sided flute channels.

Long flute, but the very tip of the preform was cut off. I'm not sure if you should complain or brag. Remodel the tip, grind a flat spot on the end;-and flute the other side. And hope like Hell it goes that far too!

You did everything right, and it broke anyway. It happens. I can't explain it and it frustrates me



to no end. But -- and these are good things -- it keeps us humble, preserves the mystery of the stone, and allows us to feel wondrous surprise when everything does go just right.

**Here are a few final tips:**

Save your channel flakes - Besides being nice to have, they're valuable study pieces to help determine reasons for failure and success. Before you flute a point, run a piece of Scotch tape down the median ridge to trap the flakes. And don't give up too quickly on the Sollberger jig. Expect some failures. Your success rate may be 20% or less for a while. At best, it will probably be about 80-90%. And as you get better, you may find that your success rate will take another dive when you start pushing the envelope, making paper thin Folsoms or ten inch Cumberlands.

I read somewhere that infrequent rewards are the most addictive. I guess some proof of that assertion can be seen in habitual gamblers who loose everything in search of the big pay-off. And then there are lab rats that perform complicated tasks to get a special food treat, even though they may be rewarded only once for every ten times they complete the task. On that philosophical note, this gambling-addicted, silica-snorting lab rat is going to go flute a Clovis point. I feel lucky.

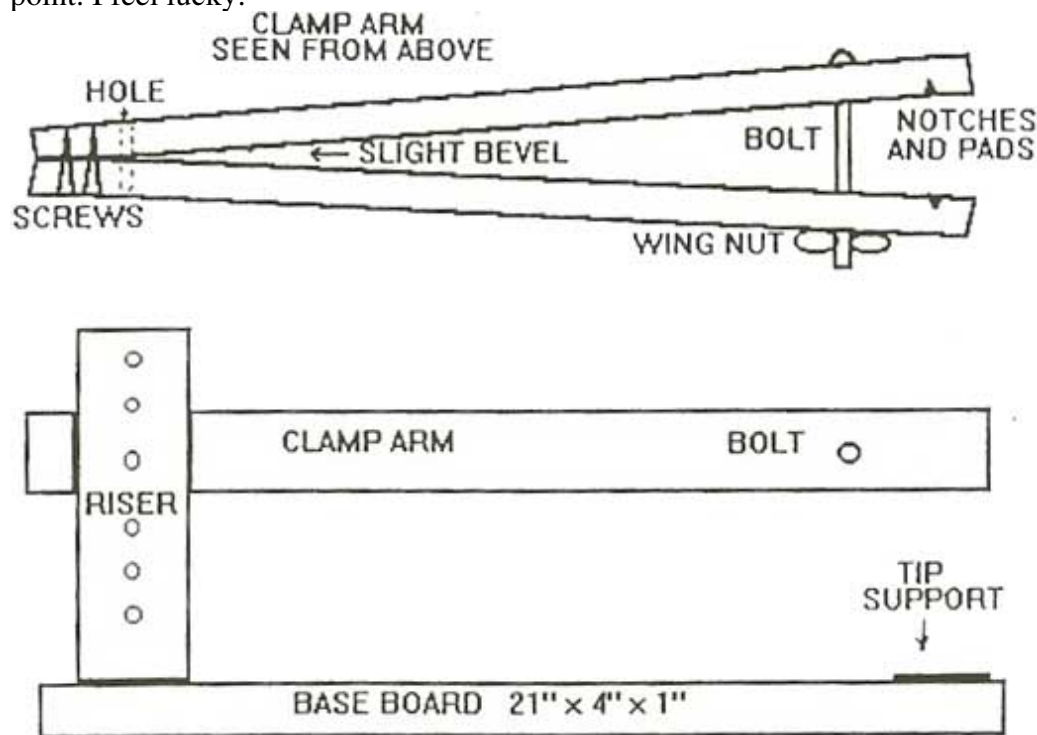

Clamp arms are 20 & 1/2".  
 Distance between notches is 1"  
 Bolt is 1 & 1/4" behind the notches.  
 Notches are 3/16" deep and 3/16" wide.  
 Holes in riser are 3/4" apart.

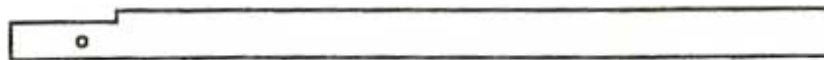

LEVER ARM, SEEN FROM SIDE  
14" long, 1 & 5/8" wide.

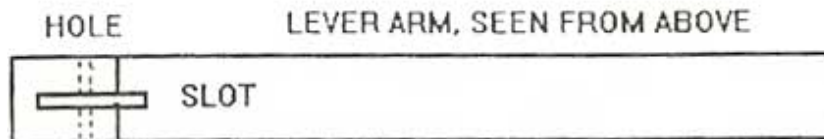

HOLE LEVER ARM, SEEN FROM ABOVE

SHELF Slot is 1 & 3/4" long, 1/4" wide.

BASE BOARD AND RISERS, SEEN FROM ABOVE

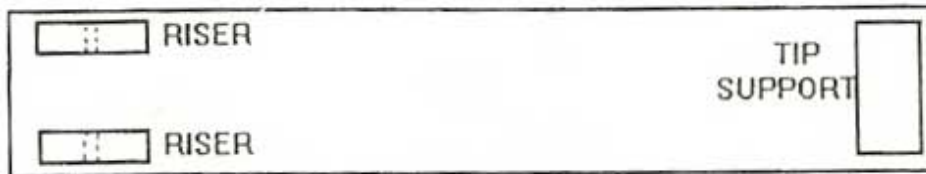

20 & 1/4" long, 3" wide.  
BUTT GOES HERE.  
STRADDLE JIG LIKE  
A SADDLE.

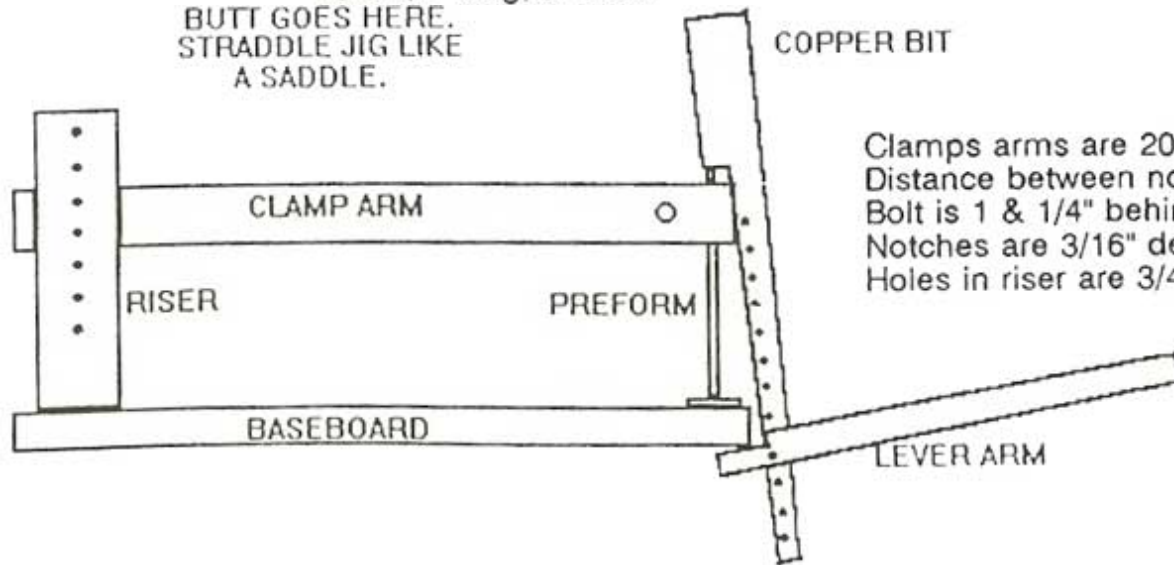

COPPER BIT

Clamps arms are 20 & 1/2"  
Distance between notches is 1"  
Bolt is 1 & 1/4" behind the notches.  
Notches are 3/16" deep and 3/16" wide  
Holes in riser are 3/4" apart.

My bit is 17" long.  
Widest point is 1 & 5/8".  
Hole centers are 5/16" apart.  
Holes are just over 1/8" diameter.  
Narrowest point is 1/2".  
Holes go along one edge.  
Contact point is inset 5/8".

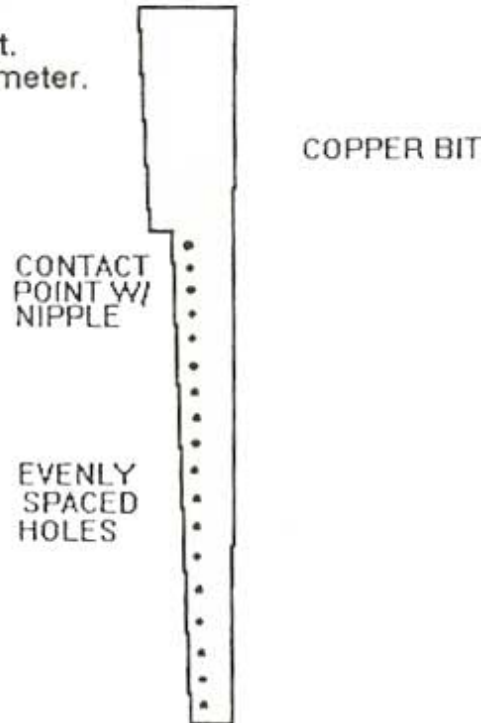

From: [http://www.pugetsoundknappers.com/how\\_to/sollberger\\_jig.html](http://www.pugetsoundknappers.com/how_to/sollberger_jig.html), accessed 12-16-10

# Notching Arrowheads

F Scott Crawford © 2009 All rights reserved

## Before You Put The Finishing Touches On The Cutting Edges Of The New Arrowhead, Begin The Vital Work Of Making Notches.

To create the notches for a small arrowhead, I make an initial narrow indentation at the chosen location for each notch. Do this with very short flakes from one side of the preform. This creates a socket for my pressure tool. Working from the same side, I rough up the inside edge a little, to get a good grip. Now, turn the point over. Press the tool against the rough edge to drive off a guide flake from the bottom face. Repeat at both locations. Then, set up the same way to make guide flakes on the opposite face. At this stage, I switch to a smaller pressure flaking tool, to work the point of the tool inside the notch. I do not want to touch the corners of the barbs or the tang when I am pressing inside the notch, or I might break them.



1. Locating the start of the notches for the point.



2. Turn over and press against the roughened edge.



3. Here is the first guide flake for this notch.



6. Press inside against the edge to remove a flake.



8. Next notch flake removed, same side as photo 6.

(Continued ...)

# Once Again, Especially In Making The Notches, Edge Preparation Is Key To Facilitating The Removal Of Pressure Flakes.

(Continues ...)



9. Trimming inside notch to prepare for next flake.



10. Turn over, press in and down against rough edge.



11. A nice, long notch flake removal.



12. Trimming inside notch to prepare for new flake.



13. Turn over, press inside against the prepared edge.



14. Nice notch flake. Clean up edges inside notches.



the face from which I want to remove the next notch flake. Now, I turn the point over and apply pressure to the new edge to remove the next flake. Repeat until I finish the notches. I keep the flaking tool sharp and I try to avoid accidentally banging the tool against the barb or the tang at the instant when I remove the notch flakes, lest I break them. *Hint: you will break the barbs, and then you will know what I mean. It is all part of the learning process.*

I repeat the setup process for each new flake in the notches. Trim the edge, working from the same side as I applied the pressure for the previous flake. Rough up the new edge with the tool. This creates a working edge close to

From <http://www.arrowhead-makeyourown.com/>, April 6, 2010, copied with permission from "How to Make Your Own Arrowheads"

# The Basics Of Punch Notching

by Mark Bracken

In the early days of flintknapping, I think we all have tried making notches in our flint points with a punch. All too often and with the greatest of ease, simply split the point in two or blow the ear off. You only have to do this two or three times to develop quite a rash.

Thank goodness for good friends and flintknappers. About three years ago a knapper from Texas named Dan Theus showed me a thing or two on punch notching. Dan can notch most anything as deep as he wants or needs to with this technique.

Using an Ishi stick or the smaller flakers has its limitations, for example..."dog leg" notches, thick points or very deep notching. Texas style Andice points are a good example of this.

In the artifact world, it appears native American Indians preferred punching their notches. This is based on the flake scars of old points. Successful punching produces large aggressive "c" shaped flakes.

Now Lets take a look at the basic rules you must follow for risk free notching. There are four basic factors for success. These are: Platform setup, grinding, strike angle and velocity. Lets look at basic platform setup.

Fig.1 shows and view of the margin. Note that the margin is not directly located on the imaginary centerline, it is for the most part, closer to the lower face of the preform. This would make any flake removal(s) more successful and less risky. The same thing applies to the tiny margin located within the notch, in a much more critical way.

Look at fig.2. It shows the margin being closer to the top face. (It's up-side-down) The flake should be removed from the "top" of the Bi-face. Having the platform edge below the imaginary centerline is a must for punching! It is the key!

Fig. 1

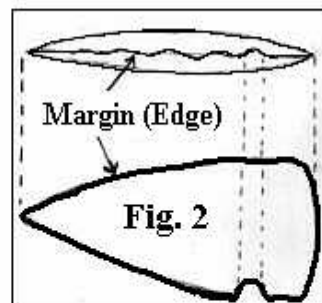
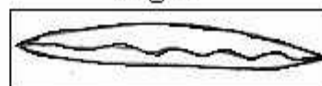
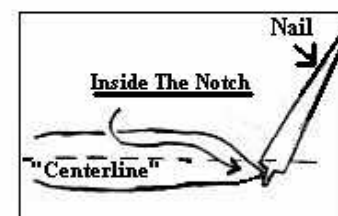
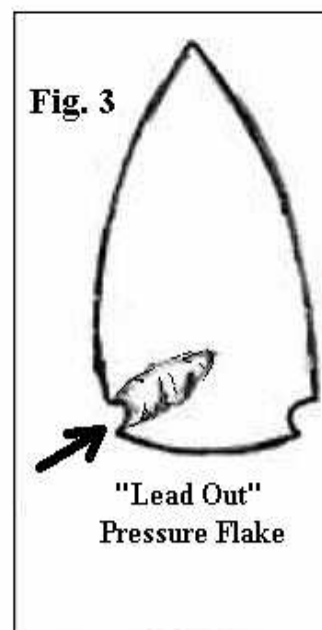

Fig. 3



To begin a notch, I like to use my ishi stick to make a "lead out" flake. Shown in Fig 3. This thins the notching area and can be done to "lower" the platform edge, I like to do this on both faces of the preform. This is not necessary but it can be a big help. Keep in mind that the notch platform is basically the same principle as a standard thinning platform.

With your platform ready as described above you must now abrade it. This is critical, even if you are doing minor adjustments to relocate the margin (something that you will occasionally have to do after punching a flake) to favor flaking the best face.

Take a look at fig.4. It shows the shoulder on the nail resting in the notch ready to punch, note that the nail shoulder is located at or slightly below the centerline of the point. Screw this up and the ear is gone! The nail will require file retouch after a few flakes.

Make sure you're not biting too much off by having too broad of a shoulder on your nail. If you have a good low platform, whack the heck out of it. You can use your billet, a chunk of wood, frozen steak or what ever to hit the nail.

A few more tips. The "lower" the platform the more you can change the angle to drive into the preform, and vice versa. Faster hits for bigger flakes and slower for smaller flakes. You can grind with a small flake. The tricky part is readjusting the margin to favor a face.



---

From <http://www.flintknappingtools.com/punch.html>, March 31, 2010, copied with permission

## Punch Notching an Andice

by Kinley Coyan (aka elremolino)

I have had a few people ask to see the tools and angles at which I notch my Andice style points. I apologize that these are not the best angles but it is difficult to both hold the punch and the point at the correct angle and try to snap the picture.



This picture simply represents the tools I use. The antler billet is the hammer I use to strike the head of the copper rivet. The first rivet is how they look when I buy them. These are 2"x1/4" sucker rod rivets used in windmilling. The second rivet has been hammered out and filed with the "nipple" left on in the center. The contact edges are actually the two shoulders, not the "nipple". I put the black pad underneath the preform to raise it off my leg so that the flakes will travel when punched. The flat, hand held, flaker is what I use to clean up and straighten the platform within each notch, before flipping it over and punching it.



Just starting to notch. The angle of my punch is not exactly correct in this photo. It is actually facing a little too far to the left side.





In the left notch you can see the white platform in the notch. This white part is where I will set one of the shoulders of the punch, and then tap it with my antler hammer.



Another angle after punching a bit deeper.



This angle shows the black pad with the basal portion of the point hanging off so that the flake will remove without any interference. This angle of the punch is correct.



One last shot with the point hanging off the rubber pad. You can see how the shoulder of the punch rests against the platform within the notch.



Finished product! Please feel free to ask questions or make comments, and sorry about the pictures.

P.S. I would say the platform is typically about 1/2" off the pad. Sometimes, if that pad isn't far enough away, you will lose your energy and the flake won't travel. Every now and then you can see where a longer flake is going to release and adjust accordingly. Basically, as I continue to notch I just slowly move the point down the pad, or the pad moves up towards the distal portion.

---

from: <http://paleoplanet69529.yuku.com/topic/40205>, accessed 12-12-10, copied with permission

# Expanding Type Notching Tutorial - Crump Lake Point

By Jim Winn (aka Paleoknapperjim)

I've been planning on doing a notching tutorial for a long time and finally got around to doing it today. Normally most of my notched points are on the small side, but trying to take pics of notching small points would be a challenge, so I chose a Crump Lake type point which is bigger. Crump Lake points are from the Crump Lake area of Oregon and are a type of Great Basin side notch point. Many are on display at the Favell Museum in Klamath Falls. Most all of them are made from black Dacite, the same material that I chose to use to make this tutorial point. Special thanks go to Chad Ring, friend and fellow knapper who took all of these pics today. This first pic shows the piece of dacite before any flakes have been removed.



Initial percussion flaking begins with Moose antler, sandstone and copper. I find the Moose antler works great in the early stages to rapidly thin the piece, many of the flakes traveling edge to edge or overshot. This picture shows the biface thinned to the desired thickness.



A little more percussion flaking has been done to shape the biface and it is now ready to pressure flake...



This pic shows the biface after the first pass of pressure flaking using an Ishi stick....



This pic shows the biface after the 2nd and final pressure flaking pass. Notice the basal thinning flakes. It is necessary to make the basal area as thin as possible in order to get narrow notches.



Here the opposite face is shown



I normally draw the starting point for my notches on the biface before notching it to be sure to get proper alignment. I use a straight edge at right angles to the long axes of the biface and place a mark on both edges on both faces. Because this point is black, I used white out instead.



The biface is now marked on both edges of both faces...



This is the edge view, showing the thinness near the basal area. This thinness is critical to successful narrow notches...



This pic shows how I support the biface on a small pad. It is very important to have very rigid control and no wiggle room anywhere. The Optivisors help a lot. If your young you may not need them, but in any case you need to be able to see real close up.



I am using a horseshoe nail for notching. This shows the placement of the tip of the notcher for the first flake removal. This first flake is taken by pressing the tip straight down, NOT IN. The idea is to take a very small flake that will set up your platform for the next flake removal on the other face.





This pic shows the first flake removed. As you can see, it is not much of a flake, but it is a starting point and we can now remove a longer flake from the opposite face...



OK, this is the oposite face flake removal, and now we are striving to push a longer flake to thin the area ahead as we go. It is absolutely essential the the tool tip be narrower than the notch. I cant stress this enough. If it is not it will rub the sides of the notch and blow it out. OK, this time I push straight in.



Here is what the 2nd flake removal looks like. It has traveled perhaps 3/16" and thinned the area ahead, looks good...



OK, this pic may look confusing, but here is what is happening. The opposite face (not shown) is where I just removed the last flake. Before removing another long flake it is necessary to get the edge of the platform as close to the face you are flaking as possible. To do this I push straight in very gently at 90 degrees to the face, just removing tiny flakes to bring the edge up. This will allow the next flake to release with less force and travel further. I NEVER grind my notches. Grinding them will stall them out and so much force will be required to remove the next flake that it will likely blow out the notch.



OK, we flip the biface over and push off another long flake on the opposite face. Again, I am pushing straight in to remove a long flake and thin the area ahead...



Here is the flake removed, not as long as I wanted but good enough...



This becomes repetitive, but here I am pushing at 90 degrees to the face again to bring the platform up to the face so that I can remove another long flake...



The biface is flipped over and we push straight in again to remove another long flake...



Here is the flake removed. This one traveled nice and far and really thinned the area ahead very well. This will make it much easier to continue. It is much easier and less risky to remove a short flake, but short flakes make it much harder to remove a flake from the opposite face. You pay the price when you go to remove the next flake. It is better to be aggressive and remove a big flake or things are sure to go wrong in a hurry..



Now we switch techniques. As the notch gets further in from the edge, it is too risky to push straight in. If the tool tip even touches the edges it will blow them off. So now we come up from underneath. Place the tool tip up on the platform and apply the force straight in as before. If the tool tip is too sharp it may bend, so you may need to file the tip a bit duller at this point. However, it still must be narrower than the notch.



Here is the flake removed. Again it travelled far and the area ahead is nice and thin and will be easy to notch...



OK, now it is time to begin expanding the notch. So now I take 2 flakes side by side on each face. Here is the first flake removal, again coming up from beneath with the tool tip...



Here is the 2nd flake removal. Notice I have moved the tool tip to the other side of the notch end.



Here are the 2 flakes just removed...



We flip the biface over and remove 2 more side by side flakes. here is the first flake removal.





Here is the 2nd flake removal...



We flip the biface over and continue. From here on, I may remove 1, 2, 3 or more flakes on each face, whatever is needed to open the notch up to the desired thickness. This part is relatively easy.



Here is the first notch completed. Now I will follow the same procedure for the 2nd notch. Note: Normally I do both notches at the same time. It is much easier to maintain symmetry by having them travel along at the same pace, rather than trying to make the 2nd notch match the first. Also, if you stall the notch out but are in far enough you can stop and call it good enough...



Here the 2nd notch is completed. Notice that I did manage to blow off a tiny pice of the 2nd opening. This happened when the tool tip accidentally touched the opening, it does not take much to blow them off!



Opposite face shown here...



Here are all the tools used to make the point from start to finish



This is another view of the notching tool unassembled. I shaped and cut a plastic bolt to a bullet shape and then heated up a horseshoe nail repeatedly over the stove and inserted it into the bolt tip until it penetrated all the way through. This fits the nail like a mold and nails are easily replaced. The handle is steel pipe with the same diameter as the bolt and makes a snug fit. A wooden dowell is glued inside the pipe to act as a stop for the bolt and nail



One final word, this is not necessarily the best way to notch a point, it is just one way of many possible ways. I tried many different techniques, most ended in failure, and after many attempts this is what is working best for me at this time...

---

From <http://paleoplanet69529.yuku.com/topic/4139>, April 1, 2010, copied with permission



*Photo courtesy of F. Scott Crawford*

## **Section 6: Finding & Treating Knappable Stone**

# Where Can I Find Flint?

by Mark Bracken

Hunting flint is one of my favorite things to do. It's an adventure every time I go on a rock hunt! Over the years I have searched far and wide for the finest and most colorful materials for knapping. Many times I have come up empty handed and an empty gas tank. I always wondered where the "Mother Lode" was or if such a thing existed. In my quest, over the years, I have found some fantastic flint sources. It is a lot of hard work yet very satisfying experience.

## **Here are some tips for *your* next rock hunt!**

The best advise I can give to the "flint hunter" is this: familiarize yourself with geological maps of the areas you plan to hunt. Look everywhere, in plowed fields, look in the gravel of creek and river bottoms, construction sites, under bridges and eroded roadside ditches. Be sure to get permission from land owners first! I assure you it is not worth the risk. The rewards are greater when material is gathered with a blessing from the land owner. Beware of "freeze fractured" flint. This is flint that has been exposed to freezing and literally frozen. The problem starts with this. Flint and all other stones contain moisture deep within the stone, when the temperature falls well below 32 f. the result of the expanding freezing moisture is fractures the flint. This is a bad thing for knappers. This material is useless unless the pieces are large enough to knap. You want pure crack free stone. It can be a serious challenge to find high grade stone. If you plan on getting material from construction sites, get them before it freezes. These stones have never been exposed to freezing temperatures and when they do, they will likely suffer. Searching creek and river bottoms can be a lot of fun. Take a big copper billet and start testing the gravel to see what is inside. You never know what you might find!

In summary, do a lot of research. Talk to artifact hunters, they know what the flints look like from their area. Don't waist your time in areas where there is no flint to be found. Don't expect other knappers to reveal their sources. Many a knapper has spent years to find their "honey holes". Remember, always get the land owners permission to hunt rocks on their property! Try to hunt areas that have not been exposed to freezing. Use common sense, have safety equipment along. Take Band-Aids, gloves, safety glasses and long pants. Just take a day off work and get a tank full of gas and have fun exploring the country side. It's great fun! you never know what you might find!

---

From [http://www.flintknappingtools.com/where\\_flint.html](http://www.flintknappingtools.com/where_flint.html), March 31, 2010, copied with permission

# Rockhounding Law

by Gregory Tolbert

## *Legal Mumbo Jumbo & Disclaimer*

We live in a country with too many lawyers and too many judges and juries who seem to be intent on eliminating the last tattered shreds of common sense. Accordingly, we begin by stating what should be obvious to everyone.

This Guide is free. You didn't pay a penny for it. And, although it is an awesome piece of work, it is a general overview. There will be errors, omissions, and even silly mistakes. In fact, there may be quite a few. Nonetheless, the authors disclaim any and all liability of any and every kind, express, implied, or otherwise. Simply stated, we're volunteering to assemble these materials so that you might have an opportunity to have some fun, maybe learn something, and spend some time experiencing the inherent magic that results from an outdoors adventure with a child.

We're not signing up for a lawsuit resulting from misplaced reliance or any other legal theory grounded ultimately in a lack of personal responsibility.

We are not your lawyer and (obviously) you are not hiring or relying on us for any legal counsel. If you need a lawyer, you need to hire a lawyer.

Be responsible. Be prepared. Plan ahead. Know your limits. Otherwise, stay home.





# ROCKHOUNDING LAW GUIDE

## FEDERAL LAW SUMMARY

Surprisingly - especially given the number of lawyers in the United States - there is not a succinct, simple, helpful, practical summary of the law pertaining to collecting rocks, minerals, gems, fossils, and artifacts.

Following a brief introduction, this Guide provides a summary chart of federal rockhounding law. Because the chart is simply a summary, it does not cover every situation or every detail. Rather, the chart is intended to provide an overview.



### INTRODUCTION

The law pertaining to rockhounding (*i.e.*, collecting rocks, gemstones, minerals, fossils, meteorites, and artifacts), is extremely complicated. Generally speaking, the applicable law depends upon four critical facts:

- (1) Ownership of the property where the collecting occurs;
- (2) The type of material — *e.g.*, rocks (such as obsidian), gemstones (such as garnets, agates, etc.), minerals (such as gold, silver, copper, etc.), petrified wood, fossils (plant, invertebrate, vertebrate, and trace), meteorites, etc.;
- (3) The manner of collecting—*e.g.*, surface collection, hand tools, digging, mechanized, blasting; and
- (4) What type of person you happen to be. Seriously, that matters.





## PROPERTY OWNERSHIP

---

The property ownership question is pretty easy. In America, all real property belongs to someone (and, increasingly, more than one person).. Generally speaking, there are two categories: Private Property and Public Property. Some may quibble that certain property ownership has elements of both (*e.g.*, tribal trust lands; taxpayer subsidized private conservation easements, etc.), but, in regard to rockhounding, these two categories will suffice.

Rockhounding on private property is easy. If you own the property or have permission to be there (*e.g.*, fee access; permit; prescriptive use; etc.), you can engage in rockhounding.

Rockhounding on public property is more complicated. Certainly, if you're not an idiot, you wouldn't expect that, just because the property is publicly owned, you could start rockhounding in the middle of the White House lawn or in a city park. On other hand, if wealthy self-proclaimed 'environmentalists' can lock up millions of acres of public property essentially for an exclusive wilderness hiking experience for a ridiculously tiny number of souls fortunate enough to have sufficient treasure and time to engage in extended wilderness 'experiences,' certainly there must be room in this country for ordinary children and their families to experience the outdoors and collect some rocks. Good news. There is. There is not a lot of opportunity and most areas are pretty remote, but, there are places where it is not illegal to collect some rocks and some fossils on public land.

Generally Speaking, in regard to federal property, certain public lands typically are closed to rockhounding.



## THE TYPE OF MATERIAL

---

When it comes to the type of material to be collected, the law varies wildly and there is no uniform rule. For example, some federal lands prohibit all collecting - rocks, gems, minerals, fossils, petrified wood, etc. On the other land, certain federal lands are open to rock collecting or to collecting a prescribed number of pounds of petrified wood, or certain fossils depending on whether they are invertebrate or vertebrate fossils. Similarly, state and local law varies. Tribal lands also vary.



## THE MANER OF COLLECTING

---

The manner of collection often is regulated. On private property, generally speaking, the method of collection is up to the property owner.

On public property where rockhounding is permissible, there often are policies pertaining to collection methods. Commonly, only nonmechanized methods may be used (*e.g.*, hand tools, picks, shovels) and, although common sense should dictate this anyway, surface improvements (*e.g.*, roads, buildings, etc.) and trees must not be damaged and the surface must be restored.



## WHO YOU ARE

---



The type of material or specimens that you may collect will depend upon your status. If, for example, you are a scientist, you will be able to collect more types of materials and specimens than if you are not (albeit not for a personal collection or sale). Similarly, if your activities are being conducted pursuant to a permit, you again will have greater latitude.

That said, if the property belongs to you, you have no legal obligation to provide access to scientists to engage in recovery or collection on your private property.



## BEFORE YOU HEAD OUT ...

---

Before you head out rockhounding, common sense would suggest that you be prepared, know where you are going, know what you plan to collect, and know for certain that the property is open to collecting. That said, common sense commonly isn't always used. Accordingly, a few tips before you head out:

- Be prepared.
- Identify the property where you plan to collect and determine its current ownership and that the property is open to rockhounding.
- If a permission or a permit is required, get it.
- Know and understand any applicable limits on your activity – *e.g.*, is there a collection limit?
- Understand and appreciate that commercial collecting is NOT recreational rockhounding.



Far too often we hear reports of ‘rockhounders’ who are cited (or occasionally merely scolded) for collecting where they are not allowed or, if allowed, collecting without a permit or collecting prohibited specimens. Such illegal activity, sadly, tarnishes the good reputation of the many decent folks who are recreational rockhounders and who do comply with the rules. Further, such illegal activity encourages private landowners to prohibit all rockhounding and provides great arguments for folks who wish to reduce or eliminate rockhounding on public lands.

In short, before you begin collecting, know where you are and investigate the applicable rules.



## UNDERSTANDING FEDERAL PUBLIC LANDS

The federal government owns an astonishing amount of real property. In fact, West of the 100th meridian, the federal government owns the majority of the real property. The BLM and USFS manage nearly half a billion acres (over 450,000,000 acres).

Some of this property is open to rockhounding subject to certain terms and conditions. Before heading out to rockhound on federal property, you should understand the different categories of federal property and the rules relevant to such categories. Keep in mind, however, that certain properties may have additional restrictions.

Generally speaking, whether rockhounding is permissible on federal property depends on three things:

- First, what type of public land (more precisely, the management regime pertaining to the public land). For example, rockhounding is prohibited in national parks (*e.g.*, Yellowstone National Park) but often is allowed in national forests.
- Second, what type of specimen - *e.g.*, rocks, gems, invertebrate fossils, vertebrate fossils, petrified wood, etc.
- Third, what type of rockhounding. This part, is very complicated. The rules vary wildly depending upon the type of rockhounding at issue - *e.g.*, simple surface rock collecting, digging, gold panning, mechanized rock collecting, etc.

### **SIGNIFICANT MANAGEMENT AGENCIES FOR FEDERAL PUBLIC LANDS**

---

Federal property is managed by a variety of federal departments, agencies, and organizations. These include:

- Bureau of Land Management (BLM)
- Bureau of Reclamation (BOR)
- Department of Defense (DOD)
- Department of Energy (DOE)
- Fish and Wildlife Service (F&WS)
- Forest Service (USFS)
- National Park Service (NPS)

Generally speaking, rockhounding by children and their families is permissible on only a couple of categories of federal property. Even in these categories, however, there are site-specific prohibitions and restrictions, additional terms and conditions, and complicated rules and exceptions. Understanding the various categories of federal ownership, however, helps set the table to understand the rules.

WHETHER ROCKHOUNDING IS ALLOWED	
MAY BE ALLOWED	PROHIBITED
Portions of BLM-managed public lands	Offices – <i>e.g.</i> , White House; federal agency buildings and campuses; GSA-managed properties, etc.
Portions of National Forests – <i>e.g.</i> , Flathead National Forest	Department of Defense properties - <i>e.g.</i> , Military bases; Firing and bombing ranges; cemeteries; etc.
Portions of National Grasslands – <i>e.g.</i> , Oglala National Grassland	Department of Energy properties - <i>e.g.</i> , Alamogordo, Hanford Nuclear Reservation; Idaho facilities
	Department of Transportation properties - <i>e.g.</i> , Interstate highways
	Bureau of Reclamation properties - <i>e.g.</i> , Dams, resevoirs
	Corps of Engineers properties - <i>e.g.</i> , Canals; etc.
	Correctional Facilities
	National Parks - <i>e.g.</i> , Yellowstone National Park
	National Monuments - <i>e.g.</i> , John Day Fossil Beds
	National Wildlife Refuges - <i>e.g.</i> , Nisqually National Wildlife Refuge

## WHETHER ROCKHOOUNDING IS ALLOWED

**MAY BE ALLOWED**

**PROHIBITED**

Wilderness Areas

Indian Sacred Sites

Historic Districts & Historic Sites

National Scenic Areas - *e.g.*,  
Columbia Gorge National Scenic  
Area



### THE BEST EVER SUMMARY CHART OF FEDERAL LAW PERTAINING TO ROCKHOOUNDING

- BLM: Bureau of Land Management
- FWS: U.S. Fish & Wildlife Service
- USFS: U.S. Forest Service
- BOR: Bureau of Reclamation
- NPS: National Park Service



GATOR GIRL ROCKS' BEST EVER SUMMARY CHART OF FEDERAL LAW PERTAINING TO ROCKHOOUNDING					
FEDERAL RESOURCE AGENCY	BLM	USFS	NPS	FWS	BOR
Acres Managed	Over 260,000,000 acres Located in the Western United States	Over 190,000,000 acres Throughout the United States			
Ownership Examples		<ul style="list-style-type: none"> <li>▪ National Forests</li> <li>▪ National Grasslands</li> <li>▪ Wilderness Areas</li> <li>▪ National Trails</li> </ul>	<ul style="list-style-type: none"> <li>▪ National Parks (e.g., Yellowstone National Park)</li> <li>▪ National Monuments (e.g., Fossil Butte National Monument)</li> </ul>	<ul style="list-style-type: none"> <li>▪ National Wildlife Refuges</li> </ul>	<ul style="list-style-type: none"> <li>▪ Federal dams</li> </ul>

GATOR GIRL ROCKS' BEST EVER SUMMARY CHART OF FEDERAL LAW PERTAINING TO ROCKHOUDING					
FEDERAL RESOURCE AGENCY	BLM	USFS	NPS	FWS	BOR
Significant Rockhounding Opportunities	<p>Some BLM-managed public lands are managed specifically to allow rockhounding:</p> <ul style="list-style-type: none"> <li>AZ: Black Hills Rockhound Area</li> <li>AZ: Round Mountain Rockhound Area (fire agate)</li> <li>OR: Glass Buttes (obsidian)</li> <li>OR: Lakeview District (sunstone)</li> <li>WA: Saddle Mountain (opalized wood)</li> </ul>	<p>Some USFS-managed public lands are managed specifically to allow rockhounding:</p> <ul style="list-style-type: none"> <li>AZ: Tonto National Forest</li> </ul>	Rockhounding is <b>PROHIBITED</b>	Rockhounding is <b>PROHIBITED</b>	Rockhounding is <b>PROHIBITED</b>
Rocks	Rocks - Generally	<p><b>Often Allowed</b></p> <ul style="list-style-type: none"> <li>"Reasonable quantities"</li> </ul> <p>There is no BLM-wide quantity safe harbor. In some areas, the petrified wood quantity is used, in other areas a descriptive volume is used - e.g., not more than can be carried in a backpack; what can fit in your trunk; etc.</p> <p>See 43 CFR 8365</p>	<p><b>Often Allowed</b></p> <ul style="list-style-type: none"> <li>Small quantities</li> <li>Personal use</li> <li>No commercial</li> </ul>	<b>PROHIBITED</b>	<b>PROHIBITED</b>
	Rocks - Decorative Stone	<p><b>Occasionally Allowed</b></p> <ul style="list-style-type: none"> <li>"Reasonable quantities" - e.g., amount that can fit into the trunk of a car</li> </ul>		<b>PROHIBITED</b>	<b>PROHIBITED</b>

GATOR GIRL ROCKS' BEST EVER SUMMARY CHART OF FEDERAL LAW PERTAINING TO ROCKHOUDING					
FEDERAL RESOURCE AGENCY	BLM	USFS	NPS	FWS	BOR
Recreational Rockhounding Generally	<b>Some Allowed</b>	<b>Some Allowed</b>	<b>PROHIBITED</b>	<b>PROHIBITED</b>	<b>PROHIBITED</b>
Commercial Activities	<b>Permit Required</b>	<b>Permit Required</b>	<b>PROHIBITED</b>	<b>PROHIBITED</b>	<b>PROHIBITED</b>
Collection Methods	<p>Recreational collection methods often vary by area. Typically, however, the following applies:</p> <ul style="list-style-type: none"> <li>No explosives</li> <li>No motorized or mechanical excavation</li> <li>No heavy equipment</li> <li>No road building</li> <li>No undue degradation of public lands</li> </ul>	<p>Recreational collection methods often vary by area. Typically, however, the following applies:</p> <ul style="list-style-type: none"> <li>No explosives</li> <li>No motorized or mechanical excavation</li> <li>No heavy equipment</li> <li>No road building</li> <li>No undue degradation of public lands</li> </ul> <p>Not infrequently, recreational rockhounding is limited to surface collection only (i.e., no shovels, picks, etc.).</p>	<b>PROHIBITED</b>	<b>PROHIBITED</b>	<b>PROHIBITED</b>
Significant Prohibitions	<ul style="list-style-type: none"> <li>Special management areas - e.g., Wilderness Areas; Wild &amp; Scenic Rivers; wildlife management areas, etc.,</li> <li>Developed Sites - e.g., campgrounds</li> </ul>	<ul style="list-style-type: none"> <li>Special management areas - e.g., Wilderness Areas; Wild &amp; Scenic Rivers; wildlife management areas; etc.</li> <li>Developed Sites - e.g., campgrounds</li> </ul>	Rockhounding is <b>PROHIBITED</b>	Rockhounding is <b>PROHIBITED</b>	Rockhounding is <b>PROHIBITED</b>

GATOR GIRL ROCKS' BEST EVER SUMMARY CHART OF FEDERAL LAW PERTAINING TO ROCKHOOUNDING						
FEDERAL RESOURCE AGENCY		BLM	USFS	NPS	FWS	BOR
	Petrified Wood	<p><b>Allowed</b></p> <ul style="list-style-type: none"> <li>Up to 25 pounds per day plus one piece</li> <li>Maximum of 250 pounds per calendar year without a permit</li> <li>For personal enjoyment</li> <li>No selling or bartering</li> </ul> <p>See 43 CFR 3622</p>	<p><b>Often Allowed</b></p> <ul style="list-style-type: none"> <li>Small quantities</li> <li>Noncommercial</li> <li>No excavation</li> </ul> <p>The BLM rules do NOT control USFS-managed public lands No uniform USFS rule</p>	<i>Permit Required</i>	<i>Permit Required</i>	<i>Permit Required</i>
Fossils	Plant Fossils	<p><b>Allowed</b></p> <ul style="list-style-type: none"> <li>Reasonable amount</li> <li>For personal enjoyment</li> <li>No selling or bartering</li> </ul>	<p><b>Often Allowed</b></p> <ul style="list-style-type: none"> <li>Small quantities</li> <li>Personal use</li> <li>No selling or bartering</li> </ul> <p>Plants fossils are assumed to be more common and may be collected in small quantities for personal use without a permit unless they have been deemed significant or the site is managed specifically for this activity, in which case a local set of rules or permits may apply for a particular site or area.</p>	<i>Permit Required</i>	<i>Permit Required</i>	<i>Permit Required</i>

GATOR GIRL ROCKS' BEST EVER SUMMARY CHART OF FEDERAL LAW PERTAINING TO ROCKHOOUNDING						
FEDERAL RESOURCE AGENCY		BLM	USFS	NPS	FWS	BOR
	Invertebrate Fossils	<p><b>Allowed</b></p> <ul style="list-style-type: none"> <li>Reasonable amount</li> <li>For personal enjoyment</li> <li>No selling or bartering</li> </ul>	<p><b>Often Allowed</b></p> <ul style="list-style-type: none"> <li>Small quantities</li> <li>Personal use</li> <li>No selling or bartering</li> </ul> <p>Invertebrate fossils are assumed to be more common and may be collected in small quantities for personal use without a permit unless they have been deemed significant or the site is managed specifically for this activity, in which case a local set of rules or permits may apply for a particular site or area.</p>	<i>Permit Required</i>	<i>Permit Required</i>	<i>Permit Required</i>
	Vertebrate Fossils	<p>It is <b>ILLEGAL</b> to collect vertebrate fossils on federal public lands without a paleontological permit. Violators will be prosecuted under the "theft of government property" provision of 18 USC 5 641 and may face a minimum fine of \$1,000 and a year in jail, and up to \$10,000 and 10 years in jail.</p> <p>As a matter of policy, vertebrate fossils are considered significant and cannot be collected without a paleontological permits which a minimum level of training and experience, provision for curation in an approved repository, and sharing of specimens.</p>				
		<i>Permit Required Recreational Rockhounds will NOT be allowed a permit</i>	<i>Permit Required Recreational Rockhounds will NOT be allowed a permit</i>	<i>Permit Required</i>	<i>Permit Required</i>	<i>Permit Required</i>
	Coral			<b>PROHIBITED</b>	<b>PROHIBITED</b>	<b>PROHIBITED</b>



GATOR GIRL ROCKS' BEST EVER SUMMARY CHART OF FEDERAL LAW PERTAINING TO ROCKHOUNDING						
FEDERAL RESOURCE AGENCY	BLM	USFS	NPS	FWS	BOR	
Artifacts	Prehistoric Artifacts - Generally	It is <b>ILLEGAL</b> to collect artifacts, including projectile points, ovate bifaces, cores, flakes, and all other material worked by prehistoric cultures and now found on public lands, without an archaeological permit. Such collecting is prohibited by the Antiquities Act of 1906 and the Archaeological Resources Protection Act of 1979.				
	Arrowheads	<i>Permit Required Recreational Rockhounds will NOT be allowed a permit</i>	<i>Permit Required Recreational Rockhounds will NOT be allowed a permit See 36 CFR 261.9(h)</i>	<i>Permit Required</i>	<i>Permit Required</i>	<i>Permit Required</i>
	Petroglyphs	<i>Permit Required Recreational Rockhounds will NOT be allowed a permit</i>	<i>Permit Required Recreational Rockhounds will NOT be allowed a permit</i>	<i>Permit Required</i>	<i>Permit Required</i>	<i>Permit Required</i>
	Cave Resources	It is <b>ILLEGAL</b> to collect paleontological resources from significant caves on public lands, without a permit. Such collecting is prohibited by the Federal Cave Resources Protection Act which authorizes misdemeanor-level penalties.				
Meteorites			<b>PROHIBITED</b>	<b>PROHIBITED</b>	<b>PROHIBITED</b>	

GATOR GIRL ROCKS' BEST EVER SUMMARY CHART OF FEDERAL LAW PERTAINING TO ROCKHOUNDING					
FEDERAL RESOURCE AGENCY	BLM	USFS	NPS	FWS	BOR
Gold Panning		<p style="text-align: center;"><b>Some Allowed</b></p> <ul style="list-style-type: none"> <li>▪ Conditions apply - e.g., no motorized operations; conduct panning in active stream</li> <li>▪ May trigger requirement for Plan of Operations (1872 Mining law)</li> </ul> <p>Note: recreational gold panning is different than prospecting and exploration. A few national forests manage a portion of the public lands for recreational gold panning.</p>	<b>PROHIBITED</b>	<b>PROHIBITED</b>	<b>PROHIBITED</b>

Note: Greg Tolbert is an attorney with considerable mineral resources and natural resources legal experience. (<http://www.avvo.com/attorneys/98063-wa-gregory-tolbert-19754.html>). Greg is one of the very few attorneys in the United States with both a law degree and an advanced legal degree in natural resources and environmental law (LL.M.) and is an honors graduate from college, law school, and his LL.M. program.

from: <http://www.gatorgirlocks.com/thebesteverguides/federallawsummary.html>, accessed 12-17-10, copied with permission

# Flintknapping Buyer's Tips

by Wilkie Collins

## *These tips could save you hundreds of dollars*

### **1) Many people who sell knapping stone do not know how to grade it very well for flintknapping.**

Silica is available at about 3 cents per pound in the form of gravel and up to 1500 dollars per pound in the form of semiprecious stones. Knappable silica is somewhere between these two figures in value, and the skill of the vendor at stone grading and his familiarity with the specific stone he sells are your only reliable access to value. Someone who offers you graded stone for less than a dollar a pound is probably offering you what most flintknappers would call "gravel".

### **2) For best value, purchase your supplies and tools from one dealer, especially while you are learning the basics.**

Knapping materials vary, and purchasing your tools from the dealer that offers the stone can help to ensure success. Some billets don't work well with everything.

### **3) Learn to flintknap with the best material you can acquire, then move on to experimenting with all of the lower grade materials that may look more like the stone your own local Indians had to use 'cause they couldn't get the good stuff.**

Heated Arkansas novaculite is a near perfect stone for the beginning flintknapper. Novaculite is less brittle than obsidian and is much safer to use. It is far more consistent than chert, can be reliably heated to knappability, and is consistently available in larger high grade pieces than other forms of silica.

Students typically learn faster with heated novaculite and experienced knappers who demonstrate look extremely competent when using novaculite as opposed to less consistent materials.

We do not recommend obsidian for beginning flintknapping because:

- a) It behaves too much like glass, and one is generally better trained by using a material more like natural stone, and
- b) It is very dangerous to chip and will leave you bleeding.

**5) Whenever possible, obtain your stone from the people who mined it, and who mined it FOR FLINTKNAPPING.**

If the person who supplies your knapping stone has purchased it second or third hand, the likelihood is great that you are getting second or third rate materials. While many dealers may protest that their stone is "#1 quality", if they did not do the mining and are not experienced flintknappers they might not even know what the best material looks like.

**Questions to ask your knapping stone dealer:**

**a) Is this stone heated?**

If it is not, it will probably be very difficult to work especially for a beginner. The exception is obsidian.

There is a tremendous difference in material that *CAN* be worked raw and material that can *EASILY* be worked raw. After teaching hundreds of students our advice is that your first 50 lbs of material be graded and heated.

**b) Is this material spalled and bifaced?**

If it is not, it *CANNOT* be graded as well as processed material, and is a risky buy. Most beginners ruin more material than they successfully spall (strike into large flakes) from blocks.

Don't be snookered into "comparing apples to oranges". Knapping material sold as a ten pound, six inch block for a dollar a pound *might* not make even a single 4 inch spall. But if you buy #1 graded spalled material with the size listed you will know what you are getting and might get several four inch spalls *PER POUND*. Two pounds of \$5.00 per pound material could very easily yield you more usable stone than 10 or 12 pounds of blocks or poorly graded stone.

The rule of thumb for knapping stone value goes basically as follows:

RAW stone is generally worth less than 50 cents per pound.

SPALLING the stone into prime spalls adds about a dollar a pound to the value.

HEATING the stone adds another dollar or so to the value of the stone.

CLEANING and BIFACING the stone rapidly adds to the value.

If your dealer has been in business for a long time, you usually get your dollar's worth in higher priced stone.

**c) What is your spall width to thickness ratio?**

If they do not know what you are talking about, they probably cannot grade stone effectively. Slight variation in the thickness of spalls or flakes can mean many more or less pieces per pound and much lower value.

**d) How much of this stone have you personally used for flintknapping?**

A dealer/flintknapper will have used many pounds of his favorite materials.

---

From <http://www.nativewayonline.com/fkfast.htm>, March 31, 2010, copied with permission

# Heat Treatment

By Travis Smolinski

**Heat treatment in itself is an art. How it was discovered by the old teachers is unknown but it was a significant invention, just as water treatment was.**

**There are many discussions on why it works, but I will only add my theory and say no more, "because it does". Treating stone allows difficult stone to become workable. Agates like Brazilian or Montana turn from blood vessel poppers into glass. This obviously has an effect on the final tool or weapon. So if you are planning on making a good sturdy axe, don't treat it. But it does not have a significant enough effect that it deteriorates the effectiveness in scrapers, knives, arrowheads or the like. It simply makes the flint knappers job more easy.**

- Fire
- Bar-b-que
- Oven/Roaster
- Kiln
- Temperatures
- Special Notes

**Some types of stone are also affected by water treatment. While I do not have enough stone to experiment with this process, one should try leaving some pieces in a bucket of water for a couple of weeks and test the results.**

**It should be noted that in regards to heat treatment, different types of stone require different temperatures. Others, such as Obsidian, require none.**

## 1) Fire

---

The old teachers use to build a pit under their fire, or in the side of a hill next to it. This was there Kiln. You should dig a fire pit large enough for the material that you would consistently be treating. Now bury the spalls (etc.) under a bed sand. A fire is now built over it. It doesn't have to be large enough to alert the fire department, just so that it heats the coals up good enough to allow them to burn throughout the night. While some people scrape all the coals off, re-layer the spalls, performs, etc., add more sand and re-light the fire, I usually skip this step and keep the fire going nicely throughout the day. After a day or more the stone is dug up and checked to see if it has been sufficiently heat treated.

Where you place them in the bed of sand will depend on what temperature they require. It has been said that 1" under the sand produces about 600 degrees of heat and will decrease about 50 degrees for every half inch deeper. Of course this assumes that all the sand is equal and that the fire is spread evenly. The edges of the sand pit would experience less heat if the fire were not over it enough.

- My first experiment at heat treatment involved a fire pit. First I dug a hole into the ground, filled it with about half a foot of sand and then layered the rocks so that they wouldn't be touching each other. Finally more sand and then we built a fire on top of it and roasted marshmallows. The next day I dug it up and noticed that there didn't appear to be much color change. Further examination of the rocks proved this as there was no change in the ease of pressure flaking the stones. Perhaps the fire wasn't hot enough?

## 2) Bar-b-Q

---

I have a small bar-b-q that I filled with sand and layered the stones accordingly. Then I lit a sufficient amount of charcoals (covered in lighter fluid) and let them burn over night. However, while I have heard that this works too, I was unsuccessful. I just can not seem to get the fire hot enough. This time I used less sand but had the same results.

- A friend told me that he cooks novaculite (requires 700-950 degrees F.) on the bar-b-que. Haven't tried it yet.

### 3) Oven/Roaster

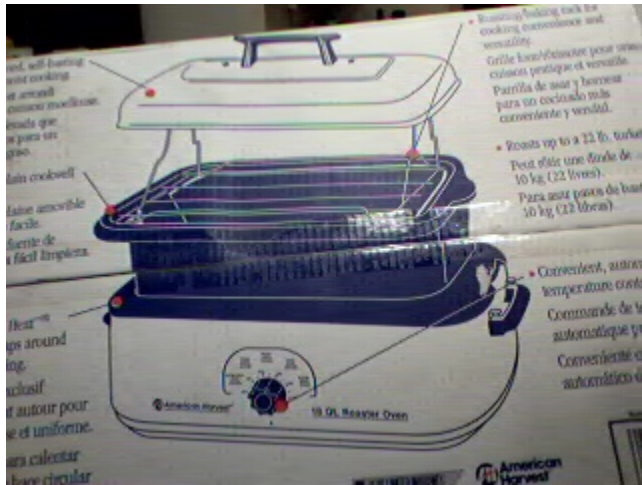

The same goes for the oven, but after the wife banned me, I got a turkey roaster and love it and would not go back. It is larger so I can put more in, spread them out differently, leave the sand in it and not worry about burning out the internal mechanisms. The 18 quart ones have temperature gauges that goes up to 450, or 550 on the more difficult ones to find. You can get the temperature up an additional 100 - 150 degrees more by removing the middle pan. They can go anywhere from \$40 to \$300. The one

pictured above was purchased brand-new for about \$45; A significant savings from a kiln!

It is simple to use. Spread the slabs (preforms) out, slabs on their side, and pour sand over then making sure they do not touch one another. Note that hotter temperatures will be generated at the very bottom of the sand (reverse from the fire method) and the sides.

I found that the best method was to:

- Heat roaster (with sand and rocks) for two hours at 100 degrees
- Bring it up 50 degrees every hour
- Once it reaches the desired temperature leave for an hour and reverse the process; Or,
- Once it reaches the desired temperature leave it there for a couple of hours and turn it off.

The above last two points really depends on the stone. Sometimes when it reaches the desired temp, it is heated perfectly. Other times, it needs to be maintained at that heat for a certain period of time. If you surpass it on some stones, they turn to dust.

Since I do not get a lot of material, I usually try and throw pieces that require 450-550 degrees together and hope for the best. I have only lost one piece of jasper and a couple small slabs of wood using this approach.

Note: Some people do not even use the sand with mixed results. They just throw the stone in and get to it. Basically the sand does two things. One it maintains the heat evenly, allowing the temperature to slowly raise and cool. And two it keeps the stone from touching one another. Both achieve the same goal by preventing surprises to the stone that might cause it to explode or crack. Since I buy rock, I will not take any chances of breakage and will stick to the sand.

When I first tried heat treatment I wanted quick and dirty rules, "how much-how long". But I quickly learnt that different rocks need different temps and hold times. To make it worse, the same

stone is NEVER the same and batches of the same rock, i.e. Brazilian Agate, may lead to different results for each slab.

### 3) Kiln

---

If you are fortunate enough to have the funds and enough material to justify purchasing a kiln, you are one of the lucky ones, otherwise you will struggle using the traditional approach or a oven. Using a kiln is very predictable and easy to measure the results. With computerized controls and an even temperature spread, you should be able to achieve the results with much greater success and ease. For a kiln be prepared to be shelling out around \$1,000. I, unfortunately, am not one of the lucky ones so I cannot offer and more information on kilns.

### Stone Cooking Temperatures

---

Here are some temperatures that I picked up and saved over the years - don't know why as I can't get most of this stuff, just hopeful I guess.

- Agate Brazilian - 450-500
- Agate India - 500
- Agate Mexican - 500
- Agate Montana - 550
- Agate Moss - 450
- Alibates - 425-500
- Bloodstone - 500
- Burlington - 600-650
- Coral - 450-600
- Dacite - NONE
- Flint Ridge - 500-600 (set the roaster at 200 degrees for two hrs then increase until the max temp. is reached and leave it for 12 to 24 hours)
- Flint - Fort Hood - 400-550
- Flint - Georgetown (Blue and Black) - NONE
- Flint - Georgetown Banded - NONE to 400
- Flint - Knife River - 350 - 450 (Do **NOT** overheat or it could pot lid)
- Flint - Danish - 300 -350
- Flint - British - 300 -350 (hold time could be 6 hours)
- Jasper Red - 500 (very hard stuff to work)
- Jasper Sunset 450-475
- Jasper Fancy 450-500



- Jasper Picture 525
- Kay County - 500-600
- Novaculate - 700-900
- Obsidian - NONE
- Pedernales - 450
- Petrified Wood - 300-450

### Special Notes on Heat Treatment

---

- All rocks are different! There is no fool proof temperature or procedure as rocks form with different minerals, flaws, cracks, moisture, etc. in them and all are different. Therefore, what might work for the majority, may not work for some. This is especially the case for petrified wood and some jaspers.
- Be careful as rocks can explode. The best ways to prevent/prepare for this are to make sure that they are thinned down first and dry (moist rocks will have a higher chance of breaking). Also, if you can, use a metal roaster with a lid. That way if it does explode, it won't go through the glass. Just joking, explosions usually means that the rocks crack and pop and do not react like a grenade.
- Make sure that your significant other doesn't know, or at-least doesn't plan on using the oven for a day or so. It may stink, especially the sand!
- Keep windows open as the oven generates a lot of heat. In addition, this cooking process soon filled up the apartment (and hallway I am sure) with the smell of cooking rocks!
- Turn off your fire alarm. From midnight until 1 a.m., when the oven was at its hottest, my alarm kept going off waking up the neighbors. I would have been caught dead in my tracks if the fire department was called out. However, make sure that you **put the battery back in afterwards** the next day or when the place cools down a bit. If your windows are open, then you may be able to skip this process.
- NEVER leave it unattended!

---

From [http://www.sparrowcreek.com/Heat\\_Treatment.htm](http://www.sparrowcreek.com/Heat_Treatment.htm), April 6, 2010, copied with permission

# Heat Treating Tips and Temperatures

by Mark Bracken

Why do we heat treat? Heat treating alters knapable material that is otherwise unchippable and transforms it to a glass like characteristic. Heat treating will also improve the colors of some flints. Browns can become reds, grays can become blues yellows become orange and so on. It's an oxidation of the minerals in the stone. Soak heating (heating for 36-48 hours at a constant temp) is not necessary but will further enhance this knapability and color change. Not all materials can be heat treated. An example of this is the black and bluish Kentucky "Horn Stone".

For the sake of simplicity, we will call all knapable stone "flints" regardless of what they are. Remember that there are different grades of all materials, So the chart below has ranges for each type and or grade. It is also important to understand that these temperatures are for spalls or pieces that are absolutely no thicker than 2 inches.

Heating thicker pieces requires lower temps and a kiln with NO air leaks. Preforms, seem to be able to take hotter temps than spalls. This is likely because of there uniform shape. The preforms can be fairly thick. This is a nice advantage for knappers who have attractive flints that knap like concrete when there raw. They can be preformed and then heated with little risk of damage.

If a material is not on the chart, experiment with it. If it seems high grade and you still want to heat it to get that glass like look or workability then start with low temps (around 350f.). A rule of thumb is this: white or gray flints take hotter temps than darker flints.

Moisture content is ever present throughout the stone in ALL flints. Some materials indicated below are very sensitive to heat due to this. They require a special drying process. With out this drying process listed below, your flint will be destroyed.

Most of our Coastal Plains (including the Jaspers and Corals) flints need special care because of this. It is not total necessary but worth it! For example: on the chart below, Flint River" chert can be heated to 450-460f. This is with the drying process. If you don't want to go through the trouble of the drying, then the max temp must be lowered to 350f. Any hotter and it WILL become damaged. Now then, if you dry it, and following my instructions below, then the stone can be heated to 450f. This is fact.

The final result for this drying process is better color and knapability with this particular type of stone. If you have heated your flint and it has not improved, you can always re heat the flint to hotter temps but you can never go back. Once you have over heated the stone, the damage is done.

I have had experiences where I know I have heated flint just a bit too hot. The stone became very unpredictable and easily developed splits at the point of impact on the platform. After some tears, the rock was put in a bucket and forgotten about for over a year. I could not bring myself to trim through it and salvage what I could. Then, after it was re discovered a year later, hidden away in my shop, I tested the flint with a billet. The same pieces that had chipped uncontrollably now became very manageable. It was awesome I might add. This has happened to me twice now and I am certain that some of the stresses caused in heating had come out of the stone over time.

\*Highly recommended drying as per directions below.

Any deviation from this will result in blown flint! That I guarantee!

First the flint must be dried...This takes about a week so be patient

Take the flint up slow and down slow, no faster than 50 degrees an hour!

Step 1. run up to 250 F and NO higher, and allow to cool to room temperature.

Step 2. run up to 250 F. and NO higher, allow to cool to room temperature.

Step 3. run up to 250 F. and NO higher, allow to cool to room temperature.

Step 4. run up to 250 F. and NO higher, allow to cool to room temperature.

Step 5. The final heating will go to 450 for high grade material

For lesser grades 460-470. {Thin Slabs may go higher}

Do Not heat whole rocks or spalls thicker than  $\frac{3}{4}$  of an inch.

Please remember...If I said it here, I mean it!

#### Basic flint heat treating instructions

Be sure the kiln is packed full with NO room for more stone. If you need to top the kiln off, get anything of poor grade to fill it up, even a brick will do! This insures that the flint will ramp up and cool slow with limited air currents within the kiln. (This causes temperature shock, which can blow up or crack your flint).

Take the flint up slowly and down slow, no faster than 50 degrees an hour.

Hold time at finished temps should be at least 3 hours. (No need to hold it longer unless your going for enhanced color)

Do Not heat whole rocks or spalls thicker than 2 inches.

#### Basic Kiln safety

Operate your kiln safely!

1. Never operate kiln on a wooden or flammable surface. Use cement blocks.

2. Place kiln elevated on concrete blocks with holes in them or a proper metal stand.

Do NOT set directly on any floor!

3. Keep kiln at least 20" from any walls or other objects at all times.

4. Use cement fiberboard on near by walls for an extra-added protection!

5. Use a "dedicated" outlet for each kiln switch on a 15-amp breaker.

6. Never heat-treat large blocks of stone. Stones could violently break apart. This could knock the lid right off a kiln ejecting VERY hot Fragments, creating a serious fire hazard!

7. Keep your kiln out of the weather, Damage to electrical parts will result.

7. Never operate kiln with flammable fumes, liquids or vapors present.

8. Avoid heat-treating in your home or living space. Heating rocks can produce poisonous or harmful vapors, even if not cut on rock saws!

9. ALWAYS WEAR A RESPIRATOR WHEN LOADING OR UNLOADING YOUR KILN!!! DUST FROM BRICKS AND ROCKS ARE DANGEROUS TO YOUR LUNGS!

**Below I have classified the materials into three grades:**

"A" = High grade, sometimes very knappable in the raw state. A slight to good gloss.

"B" = Medium grade, a dry texture. Gritty when you scratch it with your fingernail. No gloss

"C" = Quite dry in appearance. Coarse and very difficult to knap.

All Temperatures are Fahrenheit.

Some common but not all of North America's lithics.

Costal plains corals found in water	A	490-515	North Dakota "Knife River" fossil cattails	A	350-380
	B	515-540		B	
	C	540-600		C	
Costal plains corals found on land	A	450-550	Midwest "Burlington" chert	A	500-540
	B	550-600		B	540-580
	C	600-630		C	580-630
Coastal plains cherts found in water	A	520-530	Southern Alabama coastal plains cherts	A	500-530
	B	530-575		B	530-600
	C	575-650		C	650-700
Coastal plains cherts found on land	A	520-530	Tennessee agates	A	450
	B	530-575		B	500-520
	C	575-650		C	600
Costal plains chalcedony found in water	A	350	Texas "Ft. Hood" fossil stromatolites	A	500-520
	B			B	550
	C			C	
Costal plains jaspers	A	450-500	Texas Edwards Plateau river cobbles & tabular cherts	A	350
	B	500-575		B	350-400
	C	575-750		C	400-550
Costal plains "Flint River" chert	A	440-450	Texas "Georgetown"	A	350-360
	B	450-480		B	
	C	480-515		C	
Florida cherts	A	500—540	Texas "Alibates"	A	450-530
	B	540-600		B	
	C	600-700		C	

Some flints that will not heat treat:

North Dakota "Rainy Buttes" Fossil wood

Kentucky "Horn stone"

Tennessee "Ft. Payne Chert", "Dover Chert"

Pa. Ny. Ontario "Onondaga"

---

From [http://www.flintknappingtools.com/heattreating\\_temps.html](http://www.flintknappingtools.com/heattreating_temps.html), March 31, 2010, copied with permission

# Heat Treating Time/Temperature Table

by Richard Urata

This table was created from an accumulation of data from different books, and heat treating experiences of other knappers who were generous in sharing their knowledge and experience.

For additions, corrections, comments, email to Richard Urata: richurata@cybernet1.com

October 16, 2010

ITEM	ROCK	THICK (inch)	TEMP (F)	DESCRIPTION/COMMENT
1	Agate, Blackskin (India)	< .25	550	
2	Agate, Brazilian	< .40	500	Lighter - whites and tans
3	Agate, Brazilian	< .40	600 up to 700	Darker - reds and blacks
4	Agate, Bullseye (Nevada)	Any	475 - 485	Gray, solid pieces. Also called Goldfield Chalcedony and Goldfield Jasper.
5	Agate, Bullseye (Nevada)	Any	375	Colorful, banded pieces. Also called Goldfield Chalcedony and Goldfield Jasper..
6	Agate, Carnelian	> .25	500	
7	Agate, Carnelian	< .25	575	Red color
8	Agate, Montana	> .25	400	
9	Agate, Montana	< .25	450	Translucent
10	Agate, Montana	< .25	500	Clear with patterns
11	Agate, Paiute (Oregon)	> .60	500	
12	Agate, Paiute (Oregon)	< .60	600	
13	Agate, Plume (Oregon)	< .25	500	
14	Agate, Thundereggs (Oregon)	< .25	500	Clear with pink tint
15	Agate, Perkinsville Pink (Arizona)	Any	Still testing	
16	Agatized Coral	> .50	500-550	See note 1 and 3.
17	Agatized Coral	<.50	620	Max temp for 4 to 8 hours.
18	Agatized Coral (Florida)	Any	600 - 675	Light grey to white, yellow and orange. Semi-translucent to opaque.
19	Agatized Sea Stuff, Burro Creek (Arizona)	Any	350	Sea Stuff: Sponges, Clams, etc. Start at 325 and test. Increments of 25 degrees.
20	Bloodstone (India)	< .30	550	Green and Red
21	Chalcedony, Flint Ridge (Ohio)	< 1.0	600 - 650	Smooth grade, Multicolored. Opaque. Also see Chert, Flint Ridge.
22	Chalcedony, Flint Ridge (Ohio)	> 1.0	600	Smooth grade, Multicolored. Opaque. Also see Chert, Flint

23	Chalcedony, Flint Ridge (Ohio)	< .25	650	Orange. Also see Chert, Flint Ridge.
24	Chalcedony, Flint Ridge (Ohio)	Any	675	Grainier grade, Multicolored. Opaque. Also see Chert, Flint Ridge.
25	Chalcedony, Goldfield (Nevada) (Method 1)	Any	475 - 485	Gray, solid pieces. Also called Goldfield Jasper and Bullseye Agate.
26	Chalcedony, Goldfield (Nevada) (Method 1)	Any	375	Colorful, banded pieces. Also called Goldfield Jasper and Bullseye Agate.
27	Chalcedony, Goldfield (Nevada) (Method 2)	Any	400 for 48 hours	Gray, solid pieces. Also called Goldfield Jasper and Bullseye Agate.
28	Chert, Burlington (Missouri, Illinois & Iowa)	< 1.0	650 - 675	Hold max temperature for 72 hrs
29	Chert, Burlington (Missouri, Illinois & Iowa)	> 1.0	650	White, Cream, Tan and Grey. Opaque. Hold max temperature for 72 hrs. See Note 4.
30	Chert, Crescent (Missouri)	Any	650 Max	High Ridge variety. Multi-colored red, pink, purple and tan. Opaque.
31	Chert, Dongola [Cobden] (Illinois)	Any	---	Nodular, Grey to brown. Frequently with concentric banding. HEAT TREATING NOT REQUIRED
32	Chert, Flint Ridge (Ohio)	< 1.0	600 - 650	Smooth grade, Multicolored. Opaque. Also see Chalcedony, Flint Ridge.
33	Chert, Flint Ridge (Ohio)	> 1.0	600	Smooth grade, Multicolored. Opaque. Also see Chalcedony, Flint Ridge.
34	Chert, Flint Ridge (Ohio)	< .25	650	Orange. Also see Chalcedony, Flint Ridge.
35	Chert, Flint Ridge (Ohio)	Any	675	Grainier grade, Multicolored. Opaque. Also see Chalcedony, Flint Ridge.
36	Chert, Florida (Florida)	Any	600 - 650	Yellow to tan. Opaque.
37	Chert, Fort Payne (Tennessee)	Any	---	Nodular. BLACK varieties. DO NOT HEAT TREAT.
38	Chert, Fort Payne (Tennessee)	Any	500 - 675	Nodular. Banded and lighter colors like brown, tan.
39	Chert, Harvester (Missouri)	Any	550 - 625	Nodular. Cream color with brown banding. Opaque. See Note 4.
40	Chert, Homstone (Indiana)	Any	---	Nodular, Grey, sometimes banded. Opaque. HEAT TREATING NOT REQUIRED.
41	Chert, Kay County (Oklahoma)	Any	600 - 650	Light Tan to Grey. Opaque.
42	Chert, Kentucky Black (Kentucky)	Any	---	Nodular, Black to blue-black. Homstone. HEAT TREATING NOT REQUIRED.
43	Chert, Kentucky Blue (Kentucky)	Any	---	Nodular, Blue. Homstone. HEAT TREATING NOT REQUIRED.

44	Chert, Kentucky Tan (Kentucky)	< .50	600	Tan.
45	Chert, Mozarkite (Missouri)	< .50	650	Colorful
46	Chert, Pitkin (Arkansas)	Any	---	Black. Opaque. HEAT TREATING NOT REQUIRED.
47	Chert, Tan (Kentucky)	< .50	600	
48	Chert, Upper Mercer [Coshocton] (Ohio)	Any	---	Black or mottled blue-black. HEAT TREATING NOT REQUIRED
49	Coral, Agatized	>.50	500-550	See note 1 and 3.
50	Coral, Agatized	<.50	620	Max temp for 4 to 8 hours.
51	Dacite	Any	---	Any color from any location. HEAT TREATING NOT REQUIRED.
52	Flint, Alibates (Texas)	Any	450 – 500	Multi-colored, red, purple, cream and white. Opaque. See Note 1 & 4.
53	Flint, Brandon (England)	< .40	500	Thicker pieces will potlid. See Note 1, 3 & 4.
54	Flint, Brazos River (Texas)	< 2.00	600	Cobble. See Note 1, 3 & 4.
55	Flint, British (Britain)	Any	350	Nodular, Grey to Black. Opaque to semi-translucent. See Note 1 & 4.
56	Flint, Copperas Cove (Texas)	< 2.0	550	Light grey color. See Note 1, 3 & 4.
56	Flint, Danish (Europe)	Any	350	Nodular, Grey to Black. Opaque to semi-translucent. See Note 1 & 4.
57	Flint, Fort Hood (Texas)	< 2.0	600	Grey. See Note 1, 3 & 4.
57	Flint, Fort Hood [Belton] (Texas)	Any	500 - 650	Grainier. Tan Opaque. See Note 1, 3 & 4.
58	Flint, Fort Hood [Belton] (Texas)	Any	450 – 500	Smooth. Grey Opaque. See Note 1, 3 & 4.
59	Flint, Georgetown (Texas)	Any	---	Smooth. Nodular, Grey. HEAT TREATING NOT REQUIRED. See Note 4.
60	Flint, Georgetown (Texas)	Any	350 – 400	Grainier. Nodular, Grey. See Note 1, 3 & 4.
61	Flint, James River (---)	Any	---	Shades of Black. HEAT TREATING NOT REQUIRED.
62	Flint, Knife River (North Dakota)	Any	350	Brown, semi-translucent. See Note 1, 3 & 4. Potlid's easily
63	Flint, Knife River (North Dakota)	> .30	400	Brown, semi-translucent. See Note 1, 3 & 4.
64	Flint, Knife River (North Dakota)	< .30	500	Brown, semi-translucent. See Note 1, 3 & 4.
65	Flint McKittrick (California)	Any	475-485	Light brown. See Note 1, 3 & 4.
66	Flint, Pedernales (Texas)	Any	---	Smooth. Tabular. Lavender. Opaque. HEAT TREATING NOT REQUIRED. See Note 4.
67	Flint, Pedernales (Texas)	Any	350	Smooth. Tabular. Brown. Opaque. See Note 1, 3 & 4. Keep 410 F for 3 hrs. Do Not exceed 500.
68	Flint, Pedernales (Texas)	Any	580	Grainy, Tabular or Nodules. See Note 2, 3 & 4.
69	Flint, Pedernales (Texas)	Any	340 – 550	Smooth, Nodular, Brown. Opaque. See Note 1, 3 & 4.

70	Flint, R10 San Antonio (Texas)	Any	450 - 475	Darker colors. Start at 400 and test. See Note 2, 3 & 4. Don't go over 500.
71	Flint, R10 San Antonio (Texas)	Any	550	Lighter grey colors. Start at 450 and test. See Note 2, 3 & 4. Don't go over 550.
72	Flint, Rootbeer (Texas)	Any	300	Smooth, HEAT TREATING NOT REQUIRED. If heat treating, See Note 2, 3 & 4.
73	Flint, Rootbeer (Texas)	Any	410	Grainy, See Note 2, 3 & 4.
74	Flint, Uvalde, Nueces River	Any	350	Smooth, high quality. See note 2 and 3.
75	Flint, Uvalde, Nueces River	Any	450 – 500	Grainy, high quality. Hold high temp for 6 hours. See note 2 and 3.
76	Glass, man made	Any	---	Bottles, pane, stained, etc. HEAT TREATING NOT REQUIRED.
77	Jasper, Banded Purple and Grey	< .40	600	
78	Jasper, Battle Mountain (Nevada)	< .50	500	White to tan. Also called Silicified Ash.
79	Jasper, Biggs (Oregon)	< .80	550	With Pattern
80	Jasper, Biggs (Oregon)	< .80	600	Massive Grey/Brown
81	Jasper, Black	< .50	500	
82	Jasper, Bruneau (Idaho)	< .50	600	
83	Jasper, Dark Chocolate Brown	< 1.0	500	
84	Jasper, Fancy (India)	< .30	500	Red
85	Jasper, Fancy (India)	< .30	550	Pink and green
86	Jasper, Goldfield (Nevada)	Any	475 - 485	Gray, solid pieces. Also called Goldfield Chalcedony and Bullseye Agate.
87	Jasper, Goldfield (Nevada)	Any	375	Colorful, banded pieces. Also called Goldfield Chalcedony and Bullseye Agate.
88	Jasper, Imperial (Mexico)	< .30	500	Red and Green
89	Jasper, Imperial (Mexico)	< .30	650	Nodular form
90	Jasper, Maury Mountain (Oregon)	> .50	400	
91	Jasper, Maury Mountain (Oregon)	< .50	500	
92	Jasper, Mookite (Australia)	< .30	550	
93	Jasper, Mottled Brown	< .60	500	Long hold time produces color change to red.
94	Jasper, Owyhee (Oregon)	< 1.0	600	Red to green to tan
95	Jasper, Picture (Idaho)	< .40	650	
96	Jasper, Polka Dot (Oregon)	< .30	550	
97	Jasper, Red	< .50	500	



98	Jasper, Striped Brown and Red	< .60	500	
99	Jasper, Sunset (Oregon)	< .25	550	White to brown to pink
100	Novaculite (Arkansas)	Any	750 – 900	Multicolored, White, Light Grey, shades of pink, black. Opaque to semi-translucent.
101	Obsidian	Any	---	Any color from any location. HEAT TREATING NOT REQUIRED.
102	Onondaga (New York, Ontario)	Any	---	Black to mottled grey. Opaque. See Note 4. HEAT TREATMENT DOES NOT WORK.
103	Opal, common, precious	Any	---	Any color from any location. HEAT TREATING NOT REQUIRED.
104	Opalized Wood	Any	---	Any color from any location. HEAT TREATING NOT REQUIRED.
105	Petrified Wood (Arizona)	< .25	500	
106	Petrified Wood (Washington)	< .25	400	
107	Porcelainite (Montana, Wyoming, South Dakota)	Any	---	Shades of grey to Black. Maroon. Opaque. . HEAT TREATMENT DOES NOT WORK.
108	Silicified Ash, Battle Mountain (Nevada)	< .50	500	White to tan. Also called Battle Mountain Jasper.
109	Silicified Wood, Rainy Buttes (North Dakota)	Any	---	Brown. Opaque. HEAT TREATING NOT REQUIRED.
110				
111				

NOTES:

- 1) Hold at 200 F for 24 hrs to release moisture.
- 2) Hold at 200 F for 48 hrs to release moisture.
- 3) Cortex, if present, should be removed (skinned) before heat treating on all flint.
- 4) Soaking in water after heat treating improves workability.

from: [http://www.pugetsoundknappers.com/how\\_to/how\\_to.html](http://www.pugetsoundknappers.com/how_to/how_to.html), accessed 12-17-10, copied with permission



*Photo of Steve Nissly's keeper case, copied with permission*

## **Section 7: Displaying & Making Things with Your Points**

## Scanning Your Points

By Michael Miller (aka mjflinty)



I use my flatbed scanner to make the pictures of my points. The trick is to leave the lid up and to do it at night and turn off all the lights in the room. Be sure to clean the glass well first. Sometimes I do end up with a smudge or some dust and I'll use Photoshop to clean it up. One fun thing to do is to use different materials (e.g. paper, fabric, etc) and lay it on top the points to create a backdrop effect.

---

From <http://paleoplanet69529.yuku.com/topic/33645>, April 7, 2010, copied with permission

## Photographing Stone Points

Chris Merriam

I have had many people ask how I do the photography, so I thought I would take a few photos of my setup, as you can see it is fairly simple. I use a Canon powershot A 620. It comes with software so I can hook it up to my computer and see the image on my monitor before I take the photo. You can see the program's window on the left side of my monitor in the pictures below. I use the tripod and can take the photo with the click of the mouse, which is a great help when taking close up shots without the camera moving when I press the shutter release on the camera.

You can see I offset the legs of the tripod so the camera is over the table, I get good indirect sunlight that does great for showing the true color and flaking on the point.

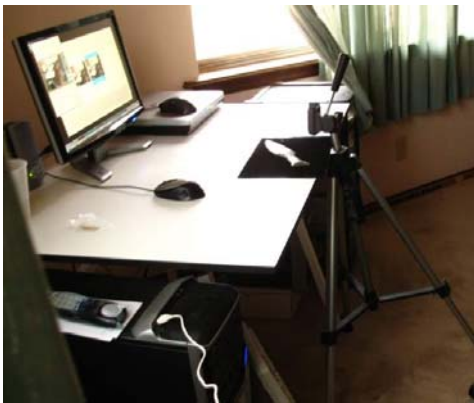

I use a plain black felt background, it works well for most points, though black material and obsidian can be a problem sometimes, mostly I just reset the contrast and it works.



For the profile, I use two notepads and slot the point in between them, it works well and allows for a variety of size artifacts, even arrowpoints work well with this method.



A side shot showing how the point sits between the pads.



Now I added the black felt background, I lay it down tight, then wiggle the point down between the pads.



Side shot.



Now for the translucent photos, as you can see, I use a small riker mount frame, and stack it on some DVD cases, CD cases work too, and by using several of these cases I can vary the height depending on the size of the point. In the top left corner you can see the camera window in the software I use to setup the shot.



Here is the light source, yep, just two little loupes with LED lights. They work surprising well, and are easy to move around to show the best translucence of the points.

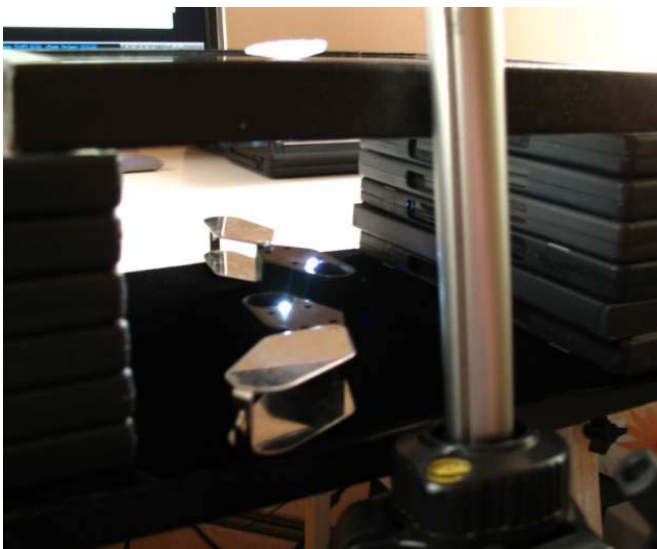

An overhead shot showing the light positioning, I set them up so one is under the base and the other near the tip, each point needs it's own fine tuning to get the most out of it.



So, that is it, for the most part... The majority of my photos are not manipulated, once the photos are done I just resize and post them.

For the trifold photos there is alot more work....

First I use Paint Shop Pro 9, but most software will do the job.

The first step is to rotate the point, it also tends to be the most time consuming part, each time the angle is slightly different so trial and error is the way I get it to line up.

Next I crop the photo as close to the point as possible, this helps to eliminate any imperfections in the background, lint, dust, etc. This also helps when it is time to resize the photos so they are all the same size.

For resizing, I use the resize tool and line up the different views of the point by using the height adjustment with the pixel setting not the percentage, this gets it closer to the full size of the photo. Since I cropped the points close in the last step this helps make sure that the different views are the same size so everything lines up well.

There can be some distortion when integrating the profile shot, since the camera is so close to the point when it is photographed sometimes the flakes dont line up perfectly, since the point comes to a tip, one part may be in focus while the rest isn't, no way to get around that, but with



a more expensive camera and a macro lens.

Once that is done, I just put the photos together in one picture and save it.

Now for the photo size and compression for the website...

What I do is set the dpi to 72, in the resize options. Most cameras use something like 180 dpi, which is half way between what is best for the internet, 72 dpi and for printing 300 dpi.

You can use 72 dpi or 96 dpi, both are fairly standard sizes, anything less and the pictures will pixelate, or look blocky, you can use some higher setting but there is no advantage to it; the file will be larger, more KB, and take longer to load. I also compress the images to 65%, different software uses different methods so for some it maybe a setting of 35, either way, make sure it is 1/3 of the way down from the highest quality. Anything below 65% and the image will look blocky and blurry.

So, that's it, all my secrets out in the open, now everyone can make great photos!

If you have any other questions please contact me, I have probably forgot a thing or two and I would be happy to provide more info.

---

From: <http://www.arrowheadsonline.com/pages/photography.htm>, accessed 6/7/10, copied with permission

## Point Displays with Girl Power

By Gary Abbatte (aka rhymeswithwhat)

Mary B. has been a very talented artist since before I met her in 1965 when we were sophomores in high school. She gets all the credit for imagineering this new point display technique. I told her my point displays were boring and looked like every body else's and that they were plain with the points all in straight rows. Then I asked her for some help. My display boxes were at her home for safe keeping while I was moving to my new apartment this spring. When I saw what she has done, I was amazed and very grateful. She has made my work look better than it is!

Here are some photos and tips on what Mary has done:



The display boxes when new have a white fiber pad, like the material that home heating filters are made from. The pads are springy but just plain white.



First Mary sprinkles a thin layer of base color of decorative sand over over the pad in the box. The colored sand is available at hobby and craft stores. It is also used in model railroad landscapes and rail-beds.



After the base color, a contrasting decorative color is sprinkled in a free hand design or pattern. Kitchen seasoning sprinkle bottles work nice for applying the sand, one sprinkle bottle for each color is needed.

Before the points are set in place, a spray adhesive is applied to the sand design. Commercial spray adhesive can be used but a mix of Elmer's clear dry glue one part. to 4 or 5 parts water in a dollar store plant misting pump spray bottle works great to apply the glue/water mix to the sand for fixing the design.to stay in place.



After arranging the points on the sand, replace the glass windowed cover and leave to dry for several days.

The sand and points and have stayed very stable through car travel to both the Bald Eagle and the Letchworth Knap-ins. That is a lot of driving vibration, but all has stayed pretty stable.



The instructions I gave will work with the Glue/Water mix by just spraying the sand to dampen like I have done with model railroad landscape. A different technique is used with commercial spray glue. First spray the pad and apply sand and lightly shake off what does not stay. Build in layers with commercial spray glue like 3M.

A very few flier specks of sand have been easily brushed away with an artist brush.

Thank You Mary.

---

From <http://paleoplanet69529.yuku.com/topic/28623>, April 7, 2010, copied with permission

# New Look for Display Case

By Steve Colby (aka Mutt.vets)

I was really impressed with Gary's post "Point's Display With Girl Power" and they way it made his points look better. <http://paleoplanet69529.yuku.com/topic/28623> I usually just shove in a piece of white foam and line up my points like a bunch of little soldiers. Well, after seeing Gary's post I felt that I needed to do something with my display box. But, I didn't want to mess with sand and glue. But then I saw this krylon paint called "stone" Krylon Stone Paint



I painted the foam pad and then just cut it out to fit into the case. Beware, if you put it on really thick, it take FOREVER to dry .....

Well, I think the whole thing turned out pretty decent. And, it has the same style of look as the ones in Gary's post. But, this is the cheater's easy way to do it .....LOL

Here's how it turned out ..... Hope your's is a success. Enjoy Mutt



From <http://paleoplanet69529.yuku.com/reply/252039#reply-252039>, April 7, 2010, copied with permission

## Cord Wrapping for an Arrowhead Necklace

By Kyle (aka Potholes Primitive)

I make necklaces for friends by stringing the cordage right to the arrowhead. I came up with this technique myself. I start by tying a hangman's noose and then wrap the point with the resulting loop and pull the noose tight. The way the point is wrapped is difficult to explain, but the example in the photo is loose so you can kind of see how in the picture. You'll probably need to play with it a while to figure it out. The result is a point that hangs straight down and a knot that won't come loose. It sure beats just tying a clove-hitch around the point like I see in novelty shops.



This necklace only has one wrap between the notches. I do two now because I think it looks better. Again, this one hasn't been cinched up all the way. The finished necklace will look almost seamless. If you can't figure it out, tell me and I'll try to draw instructions on paint.

---

From <http://paleoplanet69529.yuku.com/reply/31455#reply-31455>, April 6, 2010

# Wire Wrapping for an Arrowhead Necklace

By Jim (aka Flyfish)

This is what I do with wire. I don't remember where the drawing came from. Wish I could remember so I could give the credit.

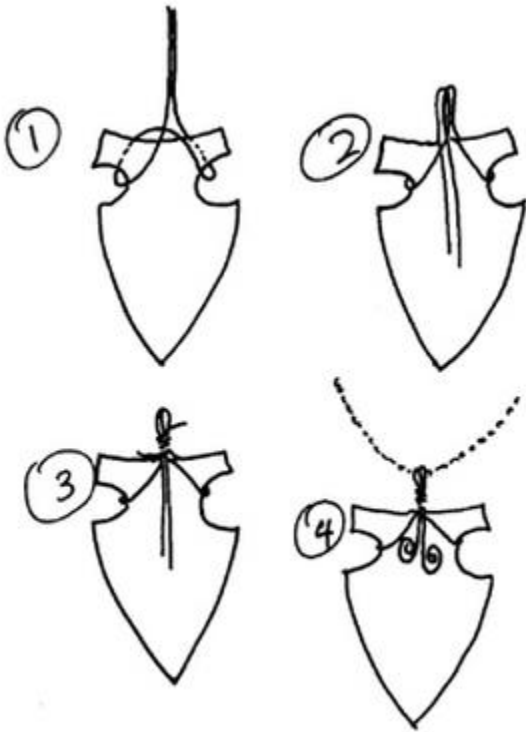

---

From <http://paleoplanet69529.yuku.com/reply/31455#reply-31455>, April 6, 2010

I heard from the artist, who wishes to remain anonymous and who wrote me that “the illustration was posted on KRU showing a technique done by James Howell.”

For a video demonstration of this technique,  
see <http://www.youtube.com/user/mjflinty#p/a/u/1/d3AWa5GGkA>

# Hafting Blades into Knives

By Travis Smolinski

Warning: Working with antler and bone dust can be hazardous. Always wear safety glasses and a mask. While I have had no problems as of yet, I have heard horror stories about people who have received awful infections from antler dust. If you have any cuts make sure they are sealed off completely.

## Modern Methods

### Wood and Antler

As wood and antler can be hafted the same way, I will discuss them both here. The main difference is that wood is easier and can be done without any use of power tools. Antler can too but it just takes a lot longer and is tougher on the tools. Stone is also done in the same way but high powered drills and diamond tools are needed.

Here is a typical style of blade that you see and an antler that I used a saw to cut it to the size I wanted. The first thing we need to do is to place the blade to the knife and determine where the best fit is. Once we see how the knife should be (general look) we place the blade to the area we need to cut.



What we are doing here is finding the area that needs to be worked to fit the blade. We then hold the blade in place and take a marker and draw out the circle where the blade will fit. If we are going to make a slot then we want to determine the thickest width of the tang (the area to be hafted)

and draw two cut lines. The finished markings will look like this.







Now we have two choices. One choice is to use a drill with various sizes of bits and drill out several holes to the depth of the tang. You can clean up the hole marks with knives and files. The hole will look like this. Then the knife will fit in the hole. Epoxy or pine pitch will hold it into place.



The other method is just as easy. With the straight lines marked you can use a jig or hand saw. First measure the tang and mark it on both the bottom and top of the handle to give you a clear vision of where to cut. The best method is to cut thin and then use a file to scrape away slowly where the tang is still wide. This method will make a tight fit and is superior to the one I will describe. The only draw back is that it could take 2 hours to

do. I used to do this method all of the time till I realized that epoxy is strong and the lashing material will hide the cuts. Therefore, I mostly use the quicker method.



Now take your saw and cut each line from start to mark. Then go down the center and angle it to each side to remove all the middle antler. You can now cut off the remaining pieces with a hand saw. You can finally clean it out with a file making sure not to remove too much from the sides. Test your blade into the slot to make sure it fits and nothing more needs to be removed.



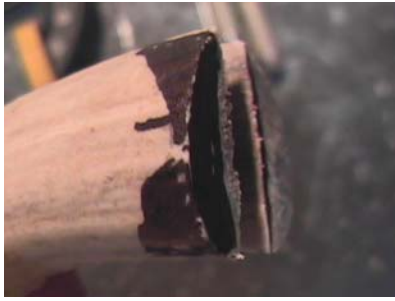

Now as an optional method we can round the sides of the antler. Take your marker and mark the areas to be removed. Now take it to the grinder and remove these areas as well as cleaning up anything on the base of the antler. If you have no grinder then this can be done with steel rasps and 60 grit sand paper. I did the hand method for years and it can be done but takes a lot longer. Finally, once in shape, take 120 grit then 220 grit sand paper and sand it down smooth.



Now the antler handle is almost finished. We need to polish it. There are two methods to use. If you don't have a power buffer then get some polyurethane spray of semi-gloss, or gloss if you want a high finish. Spray it on after



reading the instructions. You will then have to wait 72 hours before proceeding. The other method is take it to your power cloth buffer and add tripoli, a brown soap like substance. Buff it and be careful to hold it good or it will throw it. Also, I always get static shocks that causes me to jump.



Now that we have a finished handle it is time to haft the blade. I got a little careless on this one as doing two things (taking pics) was too much for my little attention span. But it is a good mistake as it shows you how to overcome problems. What I did was cut too much off so that the blade wobbles in the hafting area. This can easily be fixed by adding some wood braces That will be taken out and added after the glue has been placed in the slot.



So that we don't have a big mess it is best to tape off the blade and antler. Now we take viscous (non runny) 5- minute epoxy. One option is to add black India ink, available at any craft store. Only add enough to color the epoxy. This will turn it



black and when it dries it will look very similar to pine pitch. Set a timer for 15 minutes and fill in the slot completely with the glue. Now we do a little clean up making sure none of the glue runs and let it sit for 10 minutes. If you made the mistake like I did and the blade does not sit still then you will have to watch it moving it back into place.



Ding Ding! The timer goes off. Immediately set it again for another 15 minutes. The glue should be like play dough now. Remove the tape. Now clean up the glue with a flattened nail or similar. What you are doing here is making sure there are no lumps, no glue



away from the hafting area and finally that the hafting area is completely covered. A good thing to do is to lick your finger and push down on the glue spreading it evenly. This will give it a smooth look. Also we are still constantly making sure that the knife remains even and straight, i.e. the blade isn't leaning crooked to one side or the other. It is important to do this slowly and never forcefully. This is why it is important to do it slowly from the start. If you wait too long the glue will have set too much and you can crack the wood handle or break off the tang.

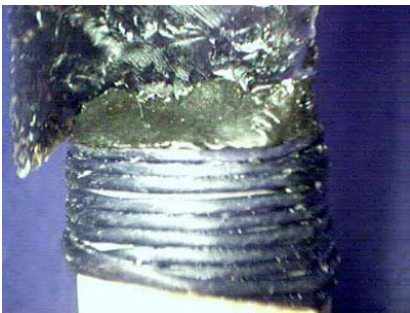

When the timer goes off again check to see that the glue is dry. Once it is, you can lash on any material that you desire. I have used hemp cord, simulated sinew, leather straps and even wool from my wife's sewing cit. A little bit of Elmer's glue will help it stay in place.



Now we let it dry for an hour or so just to make sure. Also, acetone will help take off any spilled glue. And its done.

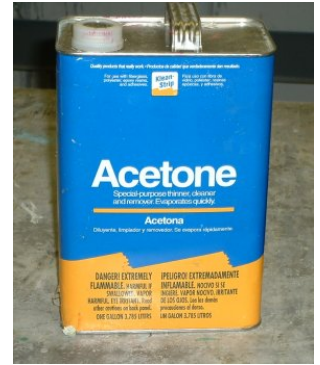

---

From [http://www.sparrowcreek.com/Hafting\\_Knives.htm](http://www.sparrowcreek.com/Hafting_Knives.htm), April 6, 2010, copied with permission